

GENERAL STANDARD

FOR

FIX FIRE FIGHTING SYSTEMS

FIRST EDITION

JANUARY 2016

FOREWORD

The Iranian Petroleum Standards (IPS) reflect the views of the Iranian Ministry of Petroleum and are intended for use in the oil and gas production facilities, oil refineries, chemical and petrochemical plants, gas handling and processing installations and other such facilities.

IPS are based on internationally acceptable standards and include selections from the items stipulated in the referenced standards. They are also supplemented by additional requirements and/or modifications based on the experience acquired by the Iranian Petroleum Industry and the local market availability. The options which are not specified in the text of the standards are itemized in data sheet/s, so that, the user can select his appropriate preferences therein.

The IPS standards are therefore expected to be sufficiently flexible so that the users can adapt these standards to their requirements. However, they may not cover every requirement of each project. For such cases, an addendum to IPS Standard shall be prepared by the user which elaborates the particular requirements of the user. This addendum together with the relevant IPS shall form the job specification for the specific project or work.

The IPS is reviewed and up-dated approximately every five years. Each standards are subject to amendment or withdrawal, if required, thus the latest edition of IPS shall be applicable

The users of IPS are therefore requested to send their views and comments, including any addendum prepared for particular cases to the following address. These comments and recommendations will be reviewed by the relevant technical committee and in case of approval will be incorporated in the next revision of the standard.

Standards and Research department

No.17, Street14, North kheradmand

Karimkhan Avenue, Tehran, Iran.

Postal Code- 1585886851

Tel: 88810459-60 & 66153055

Fax: 88810462

Email: Standards@ nioc.ir

GENERAL DEFINITIONS

Throughout this Standard the following definitions shall apply.

COMPANY :

Refers to one of the related and/or affiliated companies of the Iranian Ministry of Petroleum such as National Iranian Oil Company, National Iranian Gas Company, National Petrochemical Company and National Iranian Oil Refinery And Distribution Company.

PURCHASER :

Means the "Company" where this standard is a part of direct purchaser order by the "Company", and the "Contractor" where this Standard is a part of contract document.

VENDOR AND SUPPLIER:

Refers to firm or person who will supply and/or fabricate the equipment or material.

CONTRACTOR:

Refers to the persons, firm or company whose tender has been accepted by the company.

EXECUTOR :

Executor is the party which carries out all or part of construction and/or commissioning for the project.

INSPECTOR :

The Inspector referred to in this Standard is a person/persons or a body appointed in writing by the company for the inspection of fabrication and installation work.

SHALL:

Is used where a provision is mandatory.

SHOULD:

Is used where a provision is advisory only.

WILL:

Is normally used in connection with the action by the "Company" rather than by a contractor, supplier or vendor.

MAY:

Is used where a provision is completely discretionary.

CONTENTS:	PAGE No.
0. INTRODUCTION	3
1. SCOPE	4
2. REFERENCES	4
3. DEFINITIONS AND TERMINOLOGY	6
4. UNITS	8
SECTION 1	9
5. AUTOMATIC SPRINKLER FIRE PROTECTION SYSTEMS.....	9
5.1 General.....	9
5.2 Construction.....	9
5.5 Water Distribution	10
5.6 Coating and Plating	10
5.7 Drop Nipples for Sprinkler Systems	10
5.8 Components of Sprinkler System	11
5.9 Performance Tests.....	14
5.10 Manufacturing and Production Tests	14
5.11 Marking	15
5.12 Stock of Extra Sprinkler Heads	15
SECTION 2	19
6. CARBON DIOXIDE FIRE EXTINGUISHING SYSTEM	19
6.1 Quality of Carbon Dioxide.....	19
6.2 The Cylinder's Shell.....	19
6.3 Fittings	19
6.4 Nozzle and Discharge Horn	20
6.5 Total Flooding, Local Application and Manual Hose Reel Systems.....	20
6.6 Distribution Systems	21
6.7 Alarms and Indicators	23
6.8 Paint and Marking	23
6.9 Testing.....	24
6.10 Information to be Furnished by the Manufacturer.....	24
6.11 Shipment.....	24
6.12 Guarantee	24
SECTION 3	25
7. DRY CHEMICAL POWDER FIRE EXTINGUISHING SYSTEMS.....	25

0. INTRODUCTION

Every fire extinguishing systems have their own special features and selection of the system most suited for particular hazard shall be carefully studied and all measures relating to safeguarding human life and preservation of properties shall be considered.

Since a wide field of operations envisaged in oil, gas and petrochemical industries, it is impractical to consider every possible factors, however, the execution of fire protection standards should be entrusted to appropriately qualified and experienced fire protection engineers.

It must be specially emphasized that the fire protection systems must be regularly checked, tested, maintained and kept in good working order, as it will be nullified if the systems are not properly maintained as intended.

In this standard, some of the subjects are adapted from the following specifications:

- GENERAL SPECIFICATION **SAFETY GS SAF 321** “**Fire pump stations and fire water mains**” TOTAL Exploration & Production, Rev 01, 2010
- GENERAL SPECIFICATION **SAFETY GS SAF 322** “**Fixed fire water systems**” TOTAL Exploration & Production, Rev 01, 2010
- GENERAL SPECIFICATION **SAFETY GS SAF 334** “**Foam fire extinguishing systems**” TOTAL Exploration & Production, Rev 01, 2010

1. SCOPE

This Standard covers the minimum requirements for material specification, purchasing, fabrication, checking, testing and maintenance of fire extinguishing systems and is divided into the following sections:

- Section 1:** Sprinkler Systems and Their Components.
- Section 2:** Fix Fire Fighting Systems.
- Section 3:** Foam Fire Extinguishing Systems.
- Section 4:** Gaseous Extinguishing Systems, Clean agent.
- Section 5:** Dry Chemical Powder Extinguishing Systems.
- Section 6:** Periodic Inspection and Maintenance of Fire Fighting Systems.

Note 1:

Standard for installation, commissioning testing and operation of the above systems is covered in IPS-G-SF-505.

Note 2:

This standard specification is reviewed and updated by the relevant technical committee on Aug. 2004. The approved modifications by T.C. were sent to IPS users as amendment No. 1 by circular No. 242 on Aug. 2004. These modifications are included in the present issue of IPS.

Note 3:

This is a revised version of this standard, which is issued as revision (1)-2016. Revision (0)-1997 of the said standard specification is withdrawn.

2. REFERENCES

Throughout this Standard the following dated and undated standards/codes are referred to. These referenced documents shall, to the extent specified herein, form a part of this standard. For dated references, the edition cited applies. The applicability of changes in dated references that occur after the cited date shall be mutually agreed upon by the Company and the Vendor. For undated references, the latest edition of the referenced documents (including any supplements and amendments) applies.

IPS (IRANIAN PETROLEUM STANDARDS)

- [IPS-E-SF-200](#) "Engineering Standard for Fire Fighting Sprinkler Systems"
- [IPS-E-SF-160](#) "Engineering Standard for CO₂ Gas Fire Extinguishing Systems"
- [IPS-E-SF-180](#) "Engineering Standard for Dry Chemical Fire Extinguishing Systems"
- [IPS-C-SF-505](#) "Standard for Installation, Inspection and Testing of Fire Fighting Fixed Systems"
- [IPS-M-SF-105](#) "Material and Equipment Standard for Valves, Reels, Hoses, Nozzles and Monitors for Fir Fighting Valves"
- [IPS-M-IN-110](#) "Material and Equipment Standard for Pressure Instruments"

[IPS-E-SF-140](#)

“Engineering Standard for Foam Generating and Proportioning Systems”

UL (UNDERWRITERS LABORATORIES INC.)

- UL 199 “UL Standard for Safety Automatic Sprinklers for Fire Protection Service”
- UL 1474 “UL Standard for Safety Adjustable Drop Nipples for Sprinkler Systems”

BSI (BRITISH STANDARD INSTITUTION)

- BS 5306: P.4 “Specification for Carbon Dioxide System”
- BS 5423: Section 5
- BS 143 & 1256 “Threaded Pipe Fittings in Malleable Cast Iron and Cast Copper Alloy”
- BS EN 545 “Ductile Iron Pipes, Fittings, Accessories and their Joints for Water Pipelines - Requirements and Test Methods”
- “ 970
- “ “ 598 “Ductile Iron Pipes, Fittings, Accessories and their Joints for Sewerage Applications - Requirements and Test Methods”
- “ 1256
- “ “ 969 “Ductile Iron Pipes, Fittings, Accessories and their Joints for Gas Pipelines - Requirements and Test Methods”
- “ 1387
- “ “ 1057 “Copper and Copper Alloys - Seamless, Round Copper Tubes for Water and Gas in Sanitary and Heating Applications”
- “ 1494
- “ “ 1452 part 1 to 5 “Plastics Piping Systems for Water Supply and for Buried and Above - Ground Drainage and Sewerage under Pressure - Unplasticized Poly (Vinyl Chloride) (PVC-U)”
- “ 1580 “Unified Screw Threads”
- “ “ 1561 “Founding - Grey Cast Irons”
- “ 3601
- “ “ 1562 “Founding - Malleable Cast Irons”
- “ 3692 “ISO Metric Precision Hexagon Bolts, Screws and Nuts Specification”
- “ “ 837-1 “Pressure Gauges”
- “ 4190 “ISO Metric Black Hexagon Bolts, Screws and Nuts Specification”
- “ “ 10113
- “ 4742 “Hydraulic Equipment for Agricultural Machinery”
- “ “ 10130 “Cold Rolled Low Carbon Steel Flat Products for Cold Forming - Technical Delivery Conditions”
- “ 5839-6 “Fire Detection and Fire Alarm Systems for Buildings”
- “ 5839-9 “Fire Detection and Fire Alarm Systems for Buildings”
- “ “ 10155

“	“	10210	“Hot Finished Structural Hollow Sections of Non-Alloy and Fine Grain Steels”
“	“	10212	“Chemical Analysis of Ferrous Materials Determination of Arsenic in Steel and Iron - Spectrophotometric Method”
“	“	10216	“1 Seamless Steel Tubes for Pressure Purposes - Technical Delivery Conditions”
“	“	10217	“Welded Steel Tubes for Pressure Purposes - Technical Delivery Conditions”
“	“	10241	“Steel Threaded Pipe Fittings”

ASTM (AMERICAN SOCIETY FOR TESTING AND MATERIALS)

A53/A53M-12	“Standard Specification for Pipe, Steel, Black and Hot-Dipped, Zinc-Coated, Welded and Seamless”
A 106 Rev A	
B 31-1	

NFPA (NATIONAL FIRE PROTECTION ASSOCIATION)

NFPA 13	“Standard for the installation of sprinkler systems”
NFPA 25	“Standard for the Inspection, testing, and Maintenance of Water-Base Fire Protection System”
NFPA 11	“Standard for Low-, Medium-, and High-Expansion Foam”
NFPA 12	“Standard on Carbon Dioxide Extinguishing Systems”
NFPA 13	“Standard for the Installation of Sprinkler Systems”
NFPA 15	“Water Spray Fixed Systems”
NFPA 16	“Installation of Deluge Foam - Water Sprinkler Systems and Foam - Water Spray Systems”
NFPA 18	“Standard on wetting agents”
NFPA 30	“Flammable and Combustible Liquids Code”
NFPA 59	“Storage and Handling of Liquefied Petroleum gases at Utility Gas Plants”

3. DEFINITIONS AND TERMINOLOGY

For the purpose of this Section of Standard the following definitions used in [IPS-E-SF-200](#) shall apply.

3.1 Automatic sprinkler

A fire suppression or control device that operates automatically when its heat activated element is heated to its thermal rating or above, allowing water to discharge over a specified area.

3.2 Heat Response Point

That portion of a sprinkler operating mechanism which breaks, melts or otherwise functions on exposure to sufficient heat, thereby initiating the automatic operation of device.

3.3 Operating Temperature

The temperature (°C) at which the heat responsive element of a sprinkler operates when subjected to a 0.5°C (perminute) temperature rise while immersed in a liquid bath.

3.4 Flush Ceiling Sprinkler

A sprinkler in which only a minimum part of it project below the ceiling.

3.5 Coated or Plated Sprinkler

A sprinkler that has factory applied coatings or plating for corrosion protection or decorative purposes.

3.6 Concealed Ceiling Sprinklers

A recessed sprinkler assembly having a cover plate installed approximately flush with the wall or ceiling material for aesthetic purpose.

3.7 Dry Type Sprinkler

A sprinkler intended for installation in the upright or pendant position, designed to distribute water so that approximately 40 percent of the discharge is directed upward and 60 percent is directed downward. When installed in the upright position, this discharge will cover 3.05 m diameter circle, 3 m below the sprinkler, when the sprinkler is discharging water at the rate of 0.95 L/s.

3.8 Open Sprinkler

A sprinkler that does not have a heat responsive releasing mechanism. The discharge orifice is open.

3.9 Recessed Sprinkler

An assembly consisting of a sprinkler installed in a holder so that assembly can be recessed into the ceiling or wall.

3.10 Standard Sprinkler

A sprinkler intended for installation in the upright or pendant position, designed to distribute water downward in an umbrella shaped pattern. The discharge from a standard sprinkler having a standard orifice will cover a circle of 4.88 meters in diameter 1.22 m below the sprinkler when the sprinkler is discharging 0.95 l/s.

3.11 Extended Coverage Sprinkler

A sprinkler designed:

- 1) For use at greater than standard spacing;
- 2) To open automatically by operation of a heat responsive releasing mechanism having a response time equal to or less than a standard sprinkler used on standard spacing and;
- 3) To discharge water over the specified enclosed space having a smooth ceiling at a specified minimum operating water flow rate.

3.12 Small Room

A room of light hazard occupancy classification having unobstructed construction, and a floor area not exceeding 800 ft² (74.3m²) that is enclosed by walls and a ceiling.

Each wall in the small room is permitted to have openings to an adjoining space if the openings have a minimum lintel depth of 8 in. (200 mm) from the ceiling and the total width of the openings in each wall does not exceed 8 ft (2.4 m). A single opening of 36 in. (900 mm) or less in width without a lintel is permitted.

Note:

For other sections of this Standard, definitions and terminologies used in related engineering standard shall apply.

4. UNITS

This Standard is based on International Systems of Units (SI), except otherwise specified.

SECTION 1**5. AUTOMATIC SPRINKLER FIRE PROTECTION SYSTEMS****5.1 General**

The automatic sprinkler is a device for automatically distributing water upon a fire in sufficient quantities either to extinguish it entirely or hold it in check where it is impossible for the water to reach the fire. The water is fed to the sprinkler through a system of piping, ordinarily attached to the ceiling and the sprinklers are placed at intervals along the pipe. Water is distributed by sprinkler discharge heads consisting, essentially of a water jet impinging on a deflector which breaks the jet up into a drenching spray. The water jet is held in check by a valve, the valve being released either by a melting of a solder joint which breaks up a supporting strut or breaking of a glass bulb containing a heat expansible fluid. Quartzoid bulbs are made in different colors in accordance with its ratings. Solder types have different colored yoke arm.

5.2 Construction**5.2.1 General**

5.2.1.1 An automatic sprinkler shall be constructed to effect closure of its water seat for extended periods of time without leakage and to open as intended and release all parts as specified in this standard. The closure of the water seat shall not be achieved by the use of a dynamic O-ring or similar seal (an O-ring or similar seal that moves during operation or is in contact with a component that moves during operation).

5.2.1.2 The materials used in the construction of an automatic sprinkler shall not be subject to stress corrosion, and shall comply with the requirements as given below:

- a) Copper alloy and stainless steel parts of a sprinkler shall not be susceptible to stress, corrosion cracking when tested as described in the test for stress, corrosion, cracking of brass sprinkler parts Section 47 and 48 of UL 199.

5.2.1.3 Stampings shall show no cracking or splitting and shall be uniformly smooth and clean cut.

5.2.1.4 Deflectors of sprinklers shall be rigidly secured.

5.2.1.5 Large-orifice sprinklers shall be threaded at the inlet end 20 or 30 mm external pipe threads. If 20 mm external pipe threads are used, a pintle such as that employed to distinguish small-orifice sprinkler, shall be used.

5.2.1.6 Ceiling-type and dry-type sprinklers shall be threaded at the inlet end with 20-30 mm pipe threads.

5.2.1.7 Threads shall be clean cut and true and free from burrs, scoring or chatter marks.

5.2.1.8 When installed with the intended fitting specified in the installation instruction (see section 56 UL 199 design parameters and installation instruction), dry sprinklers installed in dry systems shall be constructed to minimize the potential to accumulate water, scale and sediment at the sprinkler inlet and shall provide an unobstructed flow pad.

5.3 Temperature Ratings

The heat response element of automatic sprinkler shall have operating temperature rating as specified in project design relative to pressure, flow and hazard classifications.

5.4 Nominal “K” Factor

5.4.1 A sprinkler shall have a discharge coefficient complying with one of the nominal “K” factor ranges specified in (see Table 11.1. in UL 199) The nominal “K” factor is to be determined from the discharge coefficient “K”, as specified by the Calibration Test, Section 49.

5.4.2 Sprinkler orifices shall have individual “K” factor values that are within ± 5 percent of the average “K” factor determined at a specific pressure for the dimensional tolerance specified by the manufacturer.

5.4.3 The diameter of a discharge orifice or any internal passage of a sprinkler shall be at least 0.21 inch (5.3 mm).

5.5 Water Distribution

5.5.1 A sprinkler shall discharge water in a spray pattern conforming to the water distribution characteristic required in this Standard.

5.6 Coating and Plating

5.6.1 The operation and distribution characteristics of a sprinkler shall not be impaired by the application of any factory applied coating or plating when sprinkler is tested.

5.7 Drop Nipples for Sprinkler Systems

5.7.1 General

5.7.1.1 Adjustable pipe nipples are intended for use with sprinkler heads to permit adjustment of the height of the sprinkler system branch line.

5.7.1.2 The products covered are intended for use in sprinkler system installed in accordance with the standard of system installation.

5.7.1.3 An adjustable drop nipple shall be constructed for a minimum rated pressure of 175 psig (1.21 Mpa).

5.7.1.4 The inlet of nipple shall be of 25 mm female pipe threads in accordance with the standard of pipe threads general purpose ASME/ANSI B1.20.1. The outlet shall have 20, 30, 50 mm female threads as specified in purchase order.

5.7.1.5 Adjustable drop nipples shall have provision for restraining the outlet end from movement during installation of a sprinkler head without damaging the components used to effect the seal, or without destroying the integrity of the seal. An adjustable, drop nipple shall also have a means to limit maximum and minimum length.

5.7.2 Metallic materials

5.7.2.1 Pressure retaining parts of an adjustable drop nipple constructed of ferrous material shall have a wall thickness of not less than 2.76 mm.

5.7.2.2 If dissimilar metals are used in adjustable drop nipples in a configuration or in proximity that would allow galvanic corrosion, the adjustable drop nipples shall be subjected to the salt spray corrosion test.

5.7.3 Non metallic seals

5.7.3.1 A rubber seal-such as O-ring or gasket used to effect the seal between the moveable and stationary parts of adjustable nipple shall be made of vulcanized natural rubber or synthetic rubber compound having uniform dimensions and of such size, shape and resiliency as to withstand ordinary wear and tear, rough usage, and damage due to pipe scale or foreign matter carried by the water.

5.7.3.2 The characteristic constituent of non-metallic seals shall be in accordance with UL 199 Clause 37, "Elastomeric Parts Tests".

5.8 Components of Sprinkler System

5.8.1 Valves-stop-test drain check and flushing valves

5.8.1.1 Valves shall comply with [IPS-M-SF-105](#).

5.8.1.2 Any valve exceeding a nominal bore of 50 mm controlling a sprinkler system shall comply with BS EN 1074: Part 1.

5.8.1.3 Test drain and flushing valves shall be right handed. Butterfly valve used as stop main valve shall be of gear operated type as specified in [IPS-M-SF-105](#).

5.8.1.4 Check valves suitable for sprinkler systems shall comply with [IPS-M-SF-105](#).

5.8.1.5 Wet composite and mechanical dry valves shall be suitable for controlling flow of water to the hydraulic alarm by the clack seat ring normally covering a part in the valve seal which communicates with the hydraulic alarm connection point.

5.8.1.6 Preaction, recycling, deluge and pressure reducing valves shall be suitable for sprinkler systems.

5.8.2 Pipe and pipe fittings

5.8.2.1 Pipes and fittings shall comply with the following Table:

Table 41. BS specifications and pipe and fittings			
Use and location	Pipe	Fittings	Comments
Water supply, below ground	BS 3505 BS 3506	BS 78 : Part 2 BS 4346	The use of plastics pipe in accordance with BS 3506 may be restricted by the water authority (see 21.1.1)
Upstream of alarm valve, below ground	BS 1211 BS 1387 BS 2035 BS 3601 BS 4622 BS 4772	 BS 2035 BS 4622 BS 4772	Heavy grade* * * *
Upstream of alarm valve, above ground	 BS 1387 BS 2035 BS 2871 : Part 1 BS 3601 BS 4622 BS 4772	BS 143 & BS 1256 BS 864 : Part 2 BS 1740 : Part 1 BS 2035 BS 4622 BS 4772	Material in accordance with BS 6681 Manipulative compression fittings only Heavy or medium grade. Galvanized heavy grade preferred. See commentary and recommendations on 21.1.1 for restriction on medium grade * For light-hazard installations only. Pipe grade superior to that given in table X. No bending of pipe * *
Downstream of alarm valve, above ground	BS 1387 BS 2871 : Part 1 BS 3602	 BS 1740 : Part 1	For light-hazard installations only. Pipe grade in accordance with table X. No bending of pipe Suitable for elevated temperatures
*Suitable for pump suction pipework with integral or welded flange or with grooved pipe mechanical joints to sockets.			

5.8.2.2 Also for materials can be used tables 6.3.1.1, 6.3.6.1, 6.4.1 and 6.4.3 of NFPA 13 (2011)

5.8.2.3 Flexible pipe or swivel joints shall be capable of withstanding at test pressure of not less than four times of the maximum working pressure or 40 bar whichever is greater and shall not include parts which, when subject to fire, may impair either the integrity or the performance of the sprinkler system. Flexible pipes shall contain continuous pressure retaining stainless or non ferrous metal inner tube.

5.8.3 Pipe supports

5.8.3.1 Pipe supports and supports fitting shall be manufactured from components and materials complying with IPS-G-PI-280, IPS-D-PI-130, IPS-D-AR-012.

The thickness of all parts of pipe supports shall not be less than:

- a) 1.2 mm for stainless steel grade 3045.38 mm in accordance with BS EN 10130 or;
- b) 3.0 mm for all other ferrous materials.

5.8.3.2 Pipe supports shall comply with the following tables of BS 5306: Part 2: Section 5:

Table 44	Test Loads for Support Assembly.
Table 45	Minimum Dimension of Pipe Clamps.
Table 46	Sling Rods and U Bolts.
Table 47	Coach Screw-coach Bolt and Bolt Fasteners.

5.8.4 Orifice plates

5.8.4.1 Orifice plates shall not be used for balancing the system.

5.8.4.2 Unless the requirements of 22.4.4.8.3 or 22.4.4.8.4 are met, mixing of sprinklers of different orifice sizes by reducing the orifice size of adjacent sprinklers on the same branch line leading back to the main for the purpose of minimizing sprinkler over discharge shall not be permitted.

5.8.4.3 Sprinklers with different orifice sizes shall be acceptable for special use such as exposure protection, small rooms or enclosures, or directional discharge. (See 3 Definition and terminology for definition of small rooms.)

5.8.4.4 Extended-coverage and residential sprinklers with a different orifice size shall be acceptable for part of the protection area where installed in accordance with their listing.

5.8.5 Alarm and alarm switches

Main control valve of each sprinkler system shall be suitable and designed for sprinkler system consisting of the following:

- a) Water motor and alarm.
- b) Hydraulic alarm test valve.
- c) Manual deluge valve if provided.
- d) Electric water flow alarm and water/air pressure switches.
- e) Stop valve mode indicator switches.
- f) Indicator panels and alarms.
- g) Electrically driven suction and booster pump switched sub circuit.
- h) System for transmission of alarm to areas, fire station and/or buildings if required, or devices which will automatically operate electrically powered audible alarm for the purpose of general alert of building evacuation. The devices, the alarm, the linkage control, the indicating control and indicating equipment shall comply with BS 5839.

5.8.6 Pressure gages

5.8.6.1 Pressure gages fitted to sprinkler installations shall comply with BS EN 8371 (also see [IPS-M-IN-110](#)).

5.8.6.2 The scale sub division shall not exceed:

- a) 0.2 bar for a maximum scale valve up-to 10 bar
- b) 0.5 bar for a maximum scale valve up-to 16 bar
- c) 1.0 bar for a maximum scale valve up-to 16 bar

5.9 Performance Tests

5.9.1 Sprinkler

5.9.1.1 To determine compliance with this material standard specification, the various types and patterns of sprinklers shall be subjected to the following performance tests and manufacturer shall certify in writing that such tests have been carried-out.

5.9.1.2 A sprinkler when tested shall be uniform and reliable in operation.

5.9.1.3 The number of samples required for investigation may vary for different types and patterns.

5.9.1.4 Sprinkler systems and components shall be tested as UL 199.

5.9.1.5 Drop nipple tests

Tests mentioned in UL 1474 are required for drop nipples which are used to adjust the height of sprinkler head.

5.10 Manufacturing and Production Tests

5.10.1 General

5.10.1.1 In order to verify compliance with these requirements in production, the manufacturers shall provide regular production quality control (inspection and tests) the program shall include at least the following:

- a) Each automatic sprinkler and adjustable nipple shall be subject of 33.3 bar (483 psi) hydrostatic leakage test with the pressure to be held for not less than 5 Seconds. Each sprinkler shall be examined for leakage.
- b) At least one sample of each temperature rating of each day production shall be subjected to the operating temperature (Bath) test, as a check on operating temperature of the fusible element.

5.10.1.2 At least one sample of the ordinary temperature rating of a heat responsive element shall be selected from each day production and subjected to a strength of heat responsive element test. Samples to be taken from each person or machine fabricating heat responsive elements to assure a constant check on the uniformity of the product.

5.11 Marking

5.11.1 The frames of all sprinklers shall show in cast or die stamped marking the manufacturer's dealer name or identifying symbol and the issue designation.

5.11.2 Small orifice and large orifice sprinkler frames having nominal 25 mm inlet threads shall also be marked by cast or stamped numerals to indicate the numeral orifice size and shall also have a pintle extended above the deflector for identification purpose.

5.11.3 Sprinklers intended for upright installation shall be permanently and prominently marked on any non-operating part with the word Upright, or the letters (SSU) (Standard Sprinkler Upright) and for the pendent installation shall be permanently and prominently marked on any non operating part with the word (Pendent) or the letters "SSP" (Standard Sprinkler Pendent).

5.11.4 Sprinklers intended for horizontal side wall installation shall be marked with the word Sidewall and Top. All other side wall sprinklers shall be marked with word Side-wall and an arrow pointing in the intended direction of flow.

5.11.5 The year of manufacture shall be die-stamped on a visible area of automatic sprinklers. Temperature rating shall be die-stamped or cast on a visible area of the fusible element of fusible alloy-type sprinklers and shall be diestamped or cast on a visible area of any part of bulb-type sprinklers. Sprinklers produced in the last 3 months of a calendar year to be marked with the following year as the date of manufacture.

5.11.6 Automatic sprinklers of various temperature rating shall have their frame arms colored in accordance with [IPS-E-SF-200](#) Clause 24 Table 32.

5.11.7 Each drop nipple shall be legibly marked with the manufacturers name or trade mark, model designation, rated pressure rating, direction of flow, and maximum temperature of sprinkler head with which it is intended to be used.

5.12 Stock of Extra Sprinkler Heads

5.12.1 Sufficient number of sprinkler heads shall be kept in stock, and reserved to replace heads that has been operated or damaged. These sprinkler heads shall be identical to the types and temperature rating of the sprinkler heads installed. These heads should be kept in a cabinet where the temperature to which they are subjected will at no time exceed 38°C. The minimum of size sprinkler heads shall be available to be used when needed. A special sprinkler wrench shall also be provided in the same place as the sprinkler heads are kept.

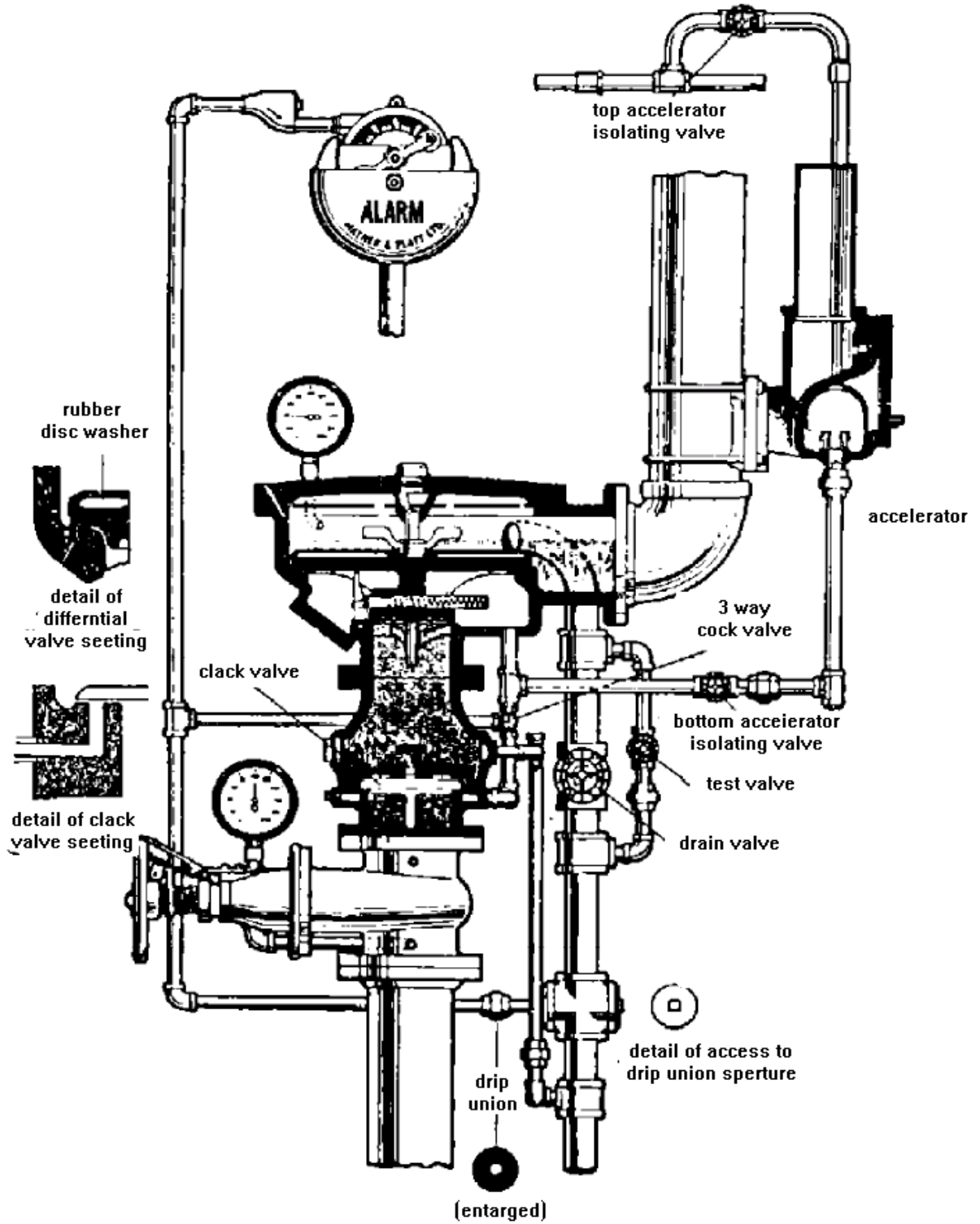

DIAGRAM OF THE CONTROL VALVES OF A TYPICAL ALTERNATE SPRINKLER INSTALLATION
Fig. 1

AUTOMATIC SPRINKLER INSTALLATIONS AND FIRE DETECTION

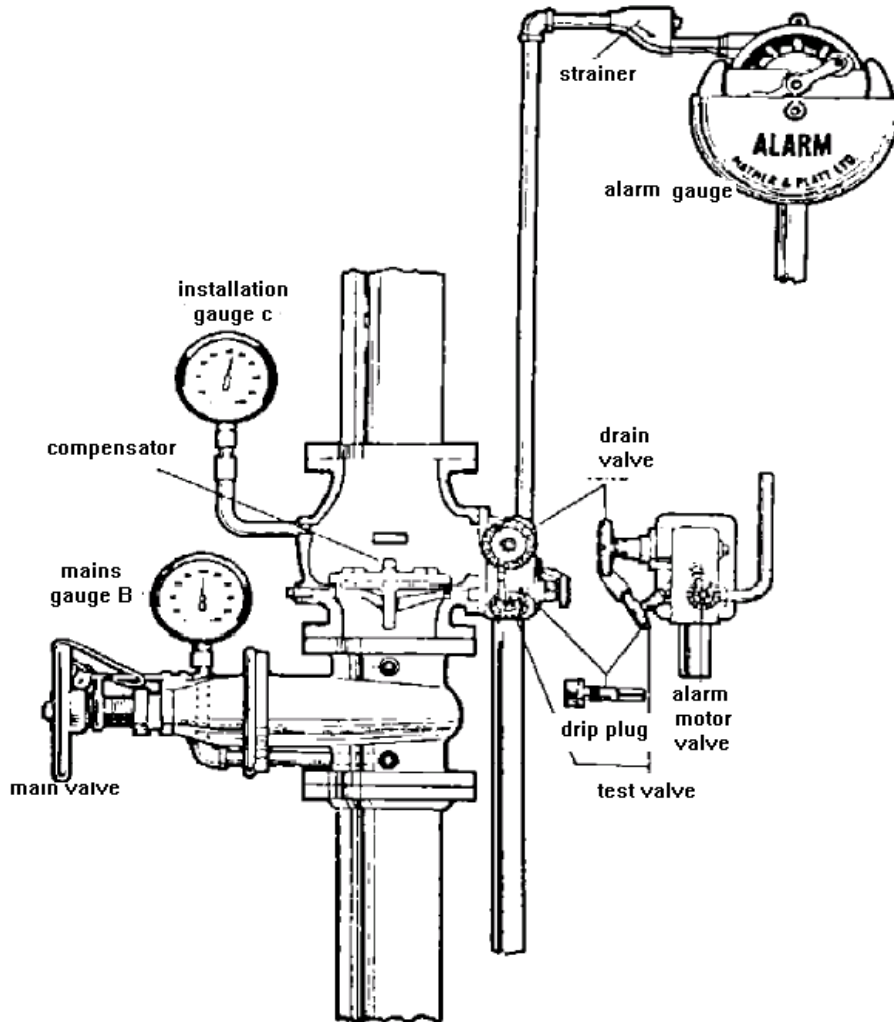
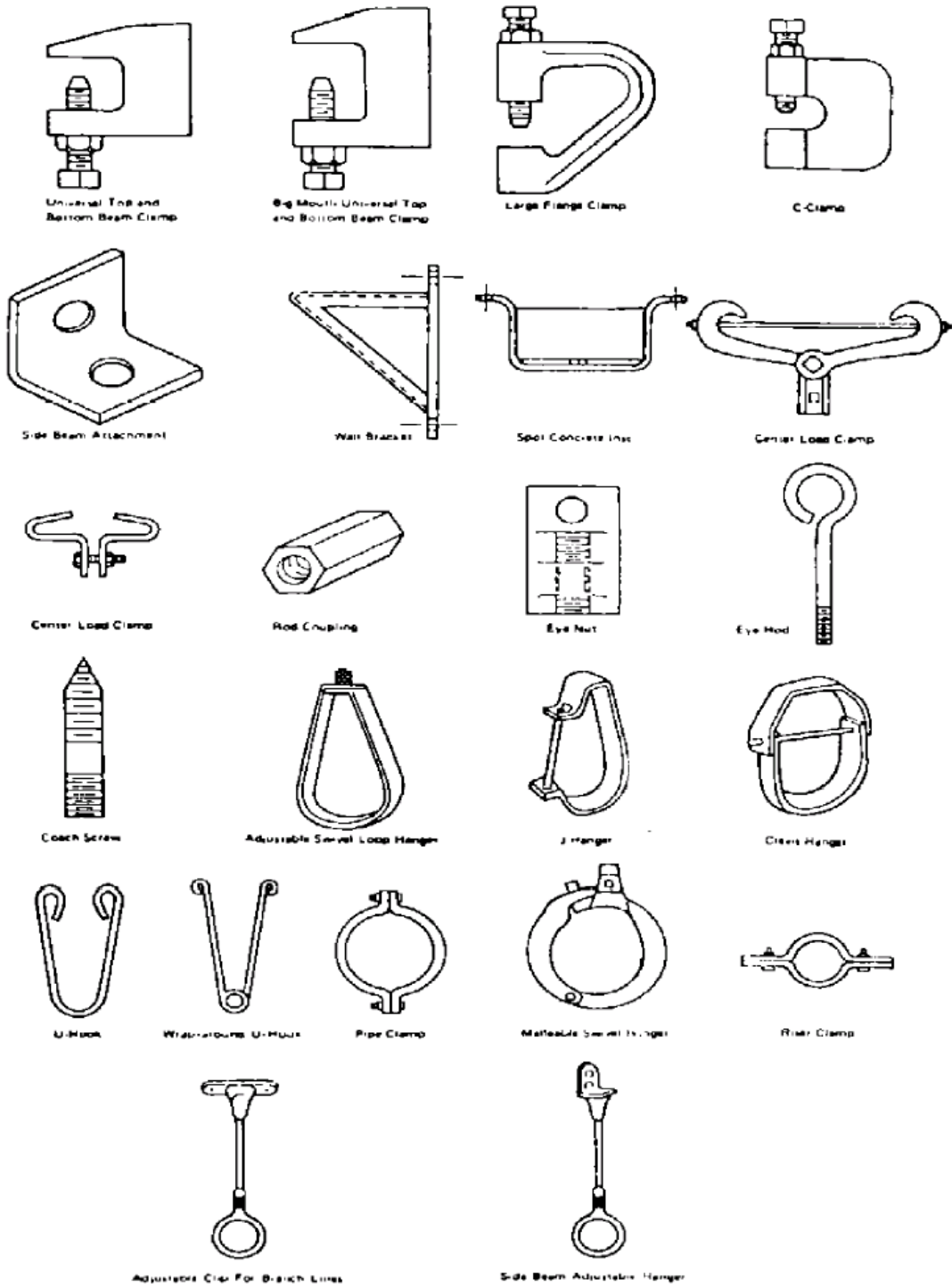

DIAGRAM OF THE CONTROL VALVES OF A TYPICAL WET SPRINKLER INSTALLATION

Fig. 2



COMMON TYPE OF ACCEPTABLE HANGERS

Fig. 3

SECTION 2**6. CARBON DIOXIDE FIRE EXTINGUISHING SYSTEM****6.1 Quality of Carbon Dioxide**

6.1.1 Carbon dioxide used for fire extinction shall be of good commercial grade, free of water and other contaminants that might cause container corrosion or interfere with free discharge through nozzle orifices. In general carbon dioxide obtained by converting dry ice to liquid shall not be used.

6.1.2 The vapor phase of carbon dioxide shall not be less than 99.5% with no detectable odor or off taste.

6.1.3 The water content of the liquid phase shall not be more than 0.01% by weight and oil content not more than 10 ppm.

6.2 The Cylinder's Shell

6.2.1 The shell used for CO₂ container shall be constructed, tested and marked in accordance with BS 5306: Part 1 and shall have the minimum service pressure of 124 bar (1798 psi).

6.2.2 The stamping on shell with marking required is accepted as evidence that the shell have been constructed and tested.

6.2.3 A shell shall be threaded at the valve opening to accommodate a discharge valve.

6.2.4 The thread strength of the valve opening shall withstand not less than ten times the maximum cylinder pressure permitted by the pressure relief mechanism.

6.2.5 The capacity of shell shall be such that when charged with the extinguishers rated capacity plus allowable tolerance of carbon dioxide does not exceed 68% of the water capacity.

6.2.6 A shell mounted valve shall be constructed of a material that is compatible with material of the shell with respect to the galvanic corrosion thread wear or galling characteristics.

6.2.7 A discharge valve shall be gas tight when closed, shall form a gas tight connection with the component of the fire extinguisher to which it is intended to be attached.

6.2.8 High pressure cylinders used in fire extinguishing systems shall not be recharged without hydrostatic test and marking, if more than 5 years have elapsed from the date of last test.

6.2.9 Each cylinder shall be provided with a safety device to release excess pressure safely in advance of the rated cylinder test pressure, frangible safety disc shall be accordingly fitted and arranged so as to release the gas at an internal pressure between 180 to 200 bar.

6.2.10 The internal discharge tube shall remain fixed to the operating head after being subjected to the test.

6.3 Fittings

Fittings including the head and any hose, with its couplings but excluding the pressure relief device fitted to carbon dioxide cylinder, shall be capable of withstanding an internal pressure of 285 +5 bar for continuous period of not less than 30 s without perceptible leakage or permanent distortion when tested.

6.4 Nozzle and Discharge Horn

6.4.1 Electric strength

When tested by the method described in Appendix L of BS 5423 Section 5, there shall be no electrical flashover or breakdown of the material of the discharge horn.

6.4.2 Adjustable horns

A horn fitted directly to the discharge head and intended to be adjustable shall be constructed with a joint which enables the horn to be directed without being held in position.

6.4.3 Securing clips

When a horn is not fitted directly to the discharge head but to a hose, provision shall be made for securing it when not in use, either by clips or other means that is provided for quick release.

6.4.4 Hand grip

Extinguishers with a hose (manual hose reel) shall have a handgrip on the nozzle or horn constructed of thermal insulating materials that will protect the operator's hand from the freezing effects of the discharge.

6.5 Total Flooding, Local Application and Manual Hose Reel Systems

6.5.1 System layout drawing

Prior to raising purchase order and installation, system lay-out drawing shall be prepared. These shall be to scale or be fully dimensioned with sufficient detail to define clearly both the hazard and proposed system. Detail of hazards shall be included to show the materials involved, the location and/or limits of hazards and any other materials that are likely to become exposed to the hazard in the event of a fire.

The means of egress from the area to be protected (in the case of total flooding) if personnel are likely to be present in the area, and the number of such persons shall be known. The location and sizes of piping and nozzles shall be clearly indicated together with the location of the carbon dioxide supply.

Fire detection devices, manual controls, all auxiliary equipment, and features such as dampers and doors related to the operation of the system shall also be shown together with detail of all calculations used in assessing the quantity of carbon dioxide. Further information shall be given separately indicating the equivalent length of pipe and fittings, flow rates and pressure drops throughout the system.

6.5.2 Types

Systems shall comply with the requirements of one of the following:

- a) Total flooding.
- b) Local application.
- c) Manual hose reel system.

6.5.3 Tests and acceptance

6.5.3.1 The installer of the equipment or his supervising supplier shall arrange tests of completed installation to the satisfaction of relevant authority to show that it complies with engineering standard [IPS-E-SF-160](#), [IPS-C-SF-505](#) Part 1 and Appendix B.

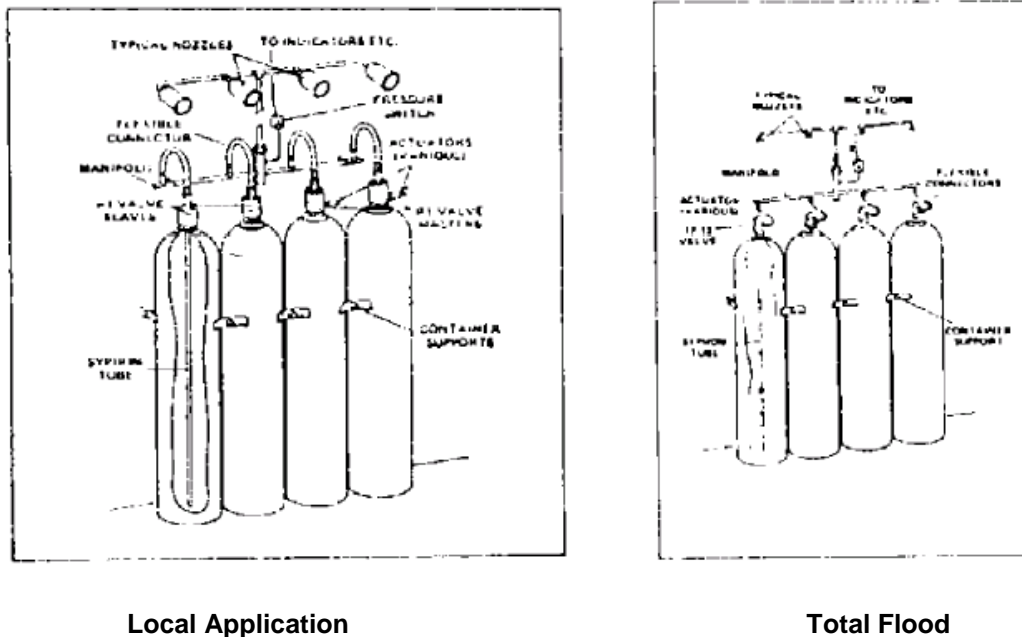

Fig. 6

6.6 Distribution Systems

6.6.1 Pipe and fittings

Piping shall be of non-combustible material having physical and chemical characteristics such that its deterioration under stress can be predicted with reliability. Special corrosion resistant materials or coatings may be required in severely corrosive atmosphere. Examples of materials for piping and the standards covering these materials are:

- a) Ferrous piping; Black or galvanized steel pipe shall be either ASTM A-53 seamless or electric welded, grade A or B or ASTM A-106, Grade A, B, or C. ASTM A-120 and ordinary cast-iron pipe shall not be used.

In systems using high pressure supply, 2 cm and smaller pipe may be schedule 40. Pipe 2½ cm through 10 cm shall be a minimum of schedule 80. Furnace butt weld ASTM-53 pipe shall not be used.

- b) This Standard does not preclude the use of other piping materials such as stainless steel or other piping or tubing providing, for high pressure supply, an internal pressure of 200 bar and for low pressure supply, an internal pressure of 30 bar which will not cause material stress greater than the material's yield point when calculated according to ANSI B-31.1, Power Piping Code.

6.6.1.1 Flexible piping, tubing, or hoses (including connections), where used, shall be of approved materials.

6.6.2 Fittings

Class 150 and cast-iron fittings shall not be used.

a) High pressure fittings

Class 300 malleable or ductile iron fittings shall be used through 5 cm (2 in) and forged steel fittings in all larger sizes. Flanged joints upstream of any stop valves shall be Class 600 and downstream of any stop valves or in systems with no stop valves may be Class 300.

b) Low pressure fittings

Class 300 malleable or ductile iron fittings shall be used through 7.5 cm (3 in) (ductile iron or forged steel fittings in all larger sizes. Flanged joints shall be class 300).

6.6.2.1 Welded joints, screwed or flanged fittings (malleable iron or ductile iron) may be used. Mechanical grooved coupling and fittings may be used if they are specifically listed for carbon dioxide service. Flush bushings shall not be used. Forged steel bushing shall be provided to maintain adequate strength. Suitable flared, compression-type, or brazed fittings shall be used with copper or brass tubing. Where brazed joints are used, the brazing alloy shall have a melting point of 538°C or higher.

6.6.2.2 In systems using high pressure supply, the piping system shall have a minimum bursting pressure of 413.7 bars (5000 psi).

6.6.2.3 In systems using low pressure supply, the piping system shall have a minimum bursting pressure of 124.1 bars (1800 psi).

6.6.3 Arrangement and installation of piping and fittings

Piping shall be installed in accordance with manufacturer's instructions.

6.6.3.1 All piping shall be laid out to reduce friction losses to a reasonable minimum and care shall be taken to avoid possible restrictions due to foreign matter or faulty fabrication.

6.6.3.2 The piping system shall be securely supported with due allowance for agent thrust forces, thermal expansion and contraction, and shall not be subject to mechanical, chemical, or other damage. Where explosions are possible, the piping system shall be hung from supports that are least likely to be displaced.

6.6.3.3 Pipe shall be reamed and cleaned before assembly, and after assembly the entire piping system shall be blown out before nozzles or discharge devices are installed.

6.6.3.4 In systems where valve arrangement introduces sections of closed piping, such sections shall be equipped with pressure relief devices or the valves shall be designed to prevent entrapment of liquid carbon dioxide. The pressure relief devices shall operate at between 165.5 and 206.9 (2400 and 3000 psi) bars on systems supplied with high pressure storage, and at 31.0 bars on systems supplied by low pressure storage. Where pressure operated cylinder valves are used, a means shall be provided to vent any cylinder gas leakage from the manifold, but which will prevent loss of gas when the system operates.

6.6.3.5 All pressure relief devices shall be of such design and so located that the discharge of CO₂ therefrom will not injure personnel or be otherwise objectionable.

6.6.4 Valves

All valves shall be suitable for the intended use, particularly with regard to flow capacity and operation. They shall be used only under temperatures and other conditions for which they are listed or approved.

6.6.4.1 Valves used in systems with high pressure storage and constantly under pressure shall have a minimum bursting pressure of 413.7 bars (6000 psi) while those not under constant pressure shall have a minimum bursting pressure of at least 344.8 bars (5000 psi).

6.6.4.2 Valves used in systems using low pressure storage shall withstand a hydrostatic test to 124.1 bars (1800 psi) without permanent distortion.

6.6.4.3 Valves shall be located installed or suitably protected so that they are not subject to mechanical, chemical, or other damage which would render them inoperative.

6.6.4.4 Valves shall be rated for equivalent length in terms of the pipe or tubing sizes with which they will be used. The equivalent length of cylinder valves shall include siphon tube, valve, discharge head and flexible connector.

6.6.5 Discharge nozzles

Discharge nozzles shall be suitable for the use intended and shall be listed or approved for discharge characteristics. The discharge nozzle consists of the orifice and any associated horn, shield, or baffle.

6.6.5.1 Discharge nozzles shall be of adequate strength for use with the expected working pressures, be able to resist nominal mechanical abuse, and constructed to withstand expected temperatures without deformation.

6.6.5.2 Discharge orifices shall be of corrosion resistant metal.

6.6.5.3 Discharge nozzles used in local application systems shall be so connected and supported that they may not readily be put out of adjustment.

6.6.5.4 Discharge nozzles shall be permanently marked to identify the nozzle and to show the equivalent single orifice diameter regardless of shape and number of orifices. This equivalent diameter shall refer to the orifice diameter of the "Standard" single orifice type nozzle having the same flow rate as the nozzle in question. The marking shall be readily discernible after installation. The "Standard" orifice is an orifice having a rounded entry with a coefficient of discharge not less than 0.98.

6.7 Alarms and Indicators

Alarms or indicators, or both, are used to indicate the operation of the system, hazard to personnel, or failure of any supervised device or equipment. The device may be audible, visual, or olfactory. The type, number, and location of the devices shall be such that their purpose is satisfactorily accomplished. The extent and type of alarm or indicator equipment, or both, shall be in accordance with [IPS-E-SF-160](#) Clause 17.

6.7.1 An alarm or indicator shall be provided to show that the system has operated and needs recharging.

6.7.2 An alarm shall be provided to indicate the operation of automatic systems and that immediate personnel response is desired.

6.7.3 Predischage alarms shall be provided to give positive warning of a discharge where hazard to personnel may exist. Such alarms shall function to warn against personnel entry into hazardous areas as long as such hazards exist or until such hazards are properly recognized.

6.7.4 Alarms indicating failure of supervised devices or equipment shall give prompt and positive indication of any failure and shall be distinctive from alarms indicating operation or hazardous conditions.

6.7.5 Control panel indicating component parts should be installed in control rooms where necessary.

6.8 Paint and Marking

CO₂ fire extinguishing systems shall be identified with corrosion resistance nameplate and easily visible. The CO₂ bulk containers shall be stored in a separate locked room and made with CO₂ extinguisher room. The nameplate shall contain the following:

- a) manufacturer's name and symbol;
- b) purchaser order, tag number;

- c) capacity of CO₂ containers and pressure at normal temperature;
- d maximum storage temperature;
- e) the date hydraulically tested and pressure;
- f) warning sign shall be provided and prominently positioned at suitable locations indicating employees actions in case of fire and operation of extinguishers;
- g) the system shall be painted with corrosion resistance primer. The finish paint shall be fire service red or as specified by purchaser.

6.9 Testing

The manufacturer shall quote all normal tests required as well as hydraulic and simulation tests and provide instructions for initial and periodic tests without loss of extinguishing agent and any special tools required for such test.

The manufacturer shall provide a letter certifying that the system components were tested and met all requirements. The manufacturer is sole responsible for the system meeting with this and IPS engineering standards.

6.10 Information to be Furnished by the Manufacturer

1) At quotation stage

The manufacturer shall furnish with his quotation the following information:

- a) Comprehensive catalogue, technical data and description of the system offered.
- b) Preliminary dimensional drawing and description of operation.
- c) List of spare parts for 5 years operation and commissioning.

2) At ordering stage

The manufacturer shall furnish the following information six weeks after receiving order:

- a) 5 sets of drawing of the system and its components fabrication shall not start until after receiving approval. All calculation data sheets shall be attached to the drawings.

6.11 Shipment

- a) Each package and equipment and material shall be properly prepared for transit to prevent damages and shall be labeled to ensure that they are not lost in transit and a list shall be provided for each package.
- b) CO₂ cylinders shall be properly protected and supplied empty which will be filled by purchaser.

6.12 Guarantee

The manufacturer shall guarantee by letter of acceptance the satisfactory performance of the system in accordance with IPS standards. The manufacturer shall also guarantee to replace without charge any or all parts defective due to faulty material, design or poor workmanship for period of 12 months after installation of the system. Any alteration necessary to meet tests and pass inspections shall be made at manufacturers expense.

SECTION 3**7. DRY CHEMICAL POWDER FIRE EXTINGUISHING SYSTEMS****7.1 Specifications, Plans and Approvals****7.1.1 Specifications**

Specifications for dry chemical fire extinguishing systems shall be drawn up with care under supervision of competent person, and with the advice of the Company's authority. To ensure a satisfactory system, the following items shall be included in the specifications.

7.1.1.1 The specifications shall designate the responsible authority and indicate whether plans are required for preengineered systems. Plans shall be required for all engine
ered systems.

7.1.1.2 The specifications shall state that the installation shall conform to this Standard and meet the approval of the Company.

7.1.1.3 The specifications shall include the specific tests that may be required, if any, to meet the approval of the Company.

7.1.1.4 These specifications shall indicate the hazard to be protected and shall include such information as physical dimensions, combustibles, air handling equipment, heat sources, etc.

7.1.2 Plans

Where plans are required, the responsibility for their preparation shall be entrusted only to competent persons.

7.1.2.1 These plans shall be drawn to an indicated scale or be suitably dimensioned, and shall be made so that they can be easily reproduced.

7.1.2.2 These plans shall contain sufficient detail to enable the Company authorities to evaluate the hazard or hazards, and to evaluate the effectiveness of the system. The details on the hazards shall include materials involved, the location and arrangement, and the exposure to the hazard.

7.1.2.3 The details on the system prepared by manufacturer at quotation stage shall include sufficient information and calculations on the amount of dry chemical; the size, length and arrangement of connected piping, or piping and hose; and description and location of nozzles so that the adequacy of the system can be determined. Flow rates of nozzles used shall be provided for engineered systems. Information shall be submitted pertaining to the location and function of detection devices, operating devices, auxiliary equipment and electrical circuitry, if used. Sufficient information shall be indicated to identify properly the apparatus and devices used.

7.1.2.4 The specification shall indicate that only listed equipment from a single manufacturer shall be used.

7.2 Operation and Control of the System**7.2.1 Methods of actuation**

Systems shall be classified as automatic or manual in accordance with the following methods of actuation:

a) Automatic operation

Operation that does not require any human action.

b) Normal manual operation

Operation of a system requiring human action shall be located near the hazard of operating devices enroute to exit way so as to be easily accessible at all times. Operation of one control shall be all that is required to bring about the full operation of the system.

c) Emergency manual operation

Operation of the system by human means where the device used to cause operation is fully mechanical in nature and is located on the device being controlled or on its mounting assembly. "Fully mechanical" may incorporate use of the system pressure to complete operation of the device.

7.2.2 Detection of fires

7.2.2.1 Fires or conditions likely to produce fire shall be detected by visual (human senses) or by automatic means.

7.2.2.2 Reliance on visual detection shall be permitted only with permission of the authority where fires or conditions likely to produce fires can be readily detected visually.

7.2.2.3 Automatic detection shall be by a listed or approved device that is capable of detecting and indicating heat, flame, smoke, combustible vapors, or an abnormal condition in the hazard, such as process trouble, that is likely to produce fire.

7.2.3 Operating devices

7.2.3.1 Operating devices shall mean expellant gas releasing mechanisms, dry chemical discharge controls, and shutdown equipment.

7.2.3.2 Operation shall be by listed mechanical, electrical, or pneumatic means.

7.2.3.3 All operating devices shall be designed for the service they will encounter, and shall not be readily rendered inoperative or susceptible to accidental operation.

7.2.3.4 At least one manual control for actuation shall be located no more than (1500 mm) above the floor and be convenient and easily accessible at all times including the time of fire.

7.2.3.5 All valves controlling the release and distribution of dry chemical shall be provided with an emergency manual control.

7.2.3.6 Means shall be provided for checking the amount of expellant gas to assure that it is sufficient for the proper operation of the system.

7.2.3.7 All shutdown devices shall be considered as integral parts of the system and shall function with the system operation. If the expellant gas is used to pneumatically operate these devices, then the gas must be taken prior to its entry into the dry chemical tank.

7.2.3.8 All remote manual operating devices shall be identified as to the hazard they protect.

7.3 Pipes and Fittings

7.3.1 Piping shall be selected and installed in accordance with [IPS-E-SF-180](#) Clause 7 "General

Design Principles".

7.3.2 The use of pipes and fittings shall involve careful consideration of the following:

- a) pressure rating;
- b) corrosion (chemical and electrolytic);
- c) method of joining;
- d) availability of fittings;
- e) resistance to fire exposure and rapid temperature change;
- f) flow characteristics.

7.3.3 Valves

7.3.3.1 All valves shall be listed for the intended use, particularly in regard to flow capacity and operation. Selector valves shall be of the quick-opening type, allowing essential free passage of the dry chemical without restriction.

7.3.3.2 Valves shall not be easily subject to mechanical, chemical, or other damages.

7.3.4 Pipe size and nozzle determination

7.3.4.1 Pipe sizes and nozzles shall be selected on the basis of calculations to deliver the required dry chemical flow rate at each nozzle or, for pre-engineered systems, in accordance with limitations set by a testing laboratory.

7.4 Discharge Nozzles

7.4.1 Discharge nozzles shall be of adequate strength for use with the expected working pressures.

7.4.2 Discharge nozzles shall be of brass, stainless steel, or other corrosion resistant materials, or be protected inside and out against corrosion. They shall be made of non-combustible materials, and shall withstand the expected fire exposure without deformation.

7.4.3 All nozzles shall be designed and subsequently located, installed or protected so that they are not subject to mechanical, environmental or other conditions that would render them inoperative.

7.4.4 Discharge nozzles shall be so connected and supported that they may not be readily put out of alignment. Where nozzles are connected directly to flexible hoses, they shall be provided with mounting brackets or fixtures to assure that they can be aligned properly and that the alignment will be maintained.

7.4.5 Discharge nozzles shall be clearly marked for identification of type and size.

7.4.6 Discharge nozzles shall be provided with blow-off caps or other suitable devices or materials to prevent the entrance of moisture or other environmental materials into the piping. The protective device shall blow-off, open or blowout upon agent discharge.

7.5 Special Requirement

7.5.1 The nitrogen gas shall be used as driving force of extinguisher and shall be sufficient to discharge %95 of dry chemical system at the specified period of time.

7.5.2 Dry chemical and nitrogen gas containers shall have the capacity specified and shall be

designed and fabricated in accordance with ASME Section VIII Boiler and pressure vessel.

7.5.3 A manual means for depressurization of partially depleted dry chemical containers shall be provided. Containers shall also be provided with manual provision for completely drainage and flushing of the container assembly.

7.5.4 A pressure relief valve shall be furnished to prevent the pressure in the tank from exceeding by 10% the maximum working pressure of the tank.

7.5.5 Dry chemical containers shall be either of spherical or cylindrical shape and shall have necessary gaseous provision to issue complete fluidization of dry chemical powder in the container at its maximum compact state and to maintain a uniform dry chemical discharge rate throughout.

7.5.6 Each tank shall be provided with pressure and level indication.

7.5.7 Each tank shall be provided with one fill cap equipped with two handles extending from opposite sides to permit hand tightening and a safety vent hole shall be located in a fill cap.

7.5.8 Nitrogen cylinders

7.5.8.1 Standard nitrogen cylinders with adequate capacity and 197 bar design pressure shall be provided as driving force. The quantity of nitrogen gas shall be adequate to expel the whole dry chemical as well as flush-out of the system.

7.5.8.2 Each gas cylinder shall have a pressure gage to indicate the pressure of nitrogen inside the cylinder.

7.6 Total and Local Flooding Systems

7.6.1 Total and local flooding systems shall be designed and installed in an enclosed area. The elimination of sources of reignition and characteristic of the area protected shall be considered. The following factors are the main points:

- a) minimum quantity of dry chemical required;
- b) minimum rate of flow of dry chemical;
- c) space limit of discharge nozzles.

7.6.2 Additional quantities of dry chemical and nozzles (if required) shall be provided to compensate for any special conditions that may adversely affect the extinguishing effectiveness of the system.

7.7 Hose Line (Reel) Application

Hand hose line (reel) system is a hose and nozzles assembly connected to a fixed pipe directly to a supply of dry chemical. The hand hose reel shall be easily accessible and the hose line should be long enough to reach the most distinct hazard that it is expected to protect. In general the unit shall be located where it would not be exposed to hazards. Manual actuation of the system shall be made possible at each hose reel station.

7.7.1 Equipment specification

7.7.1.1 Hose

Hose lines of system shall incorporate hose listed for this purpose. Normally identifying marking on the hose will indicate the acceptability of the hose.

7.7.1.2 Nozzle assemblies

Nozzles shall be so designed that they can be handled by one person and shall incorporate a quick-opening shutoff arrangement to control the flow of dry chemical.

7.7.1.3 Hose line storage

The hose shall be coiled on a hose reel or rack so that it will be ready for immediate use without the necessity of coupling and may be uncoiled with a minimum of delay. If installed outdoors, it shall be protected against the weather.

7.7.1.4 Pre-engineered dry chemical hand hose line systems may be provided with monitors, skid-mounted hose reels, remote hose reels or combinations of the above.

7.7.1.5 The length and size of piping, hose and type of nozzles shall be within the limitations stated in the manufacturer's installation manual.

7.7.1.6 Differences in elevation between the dry chemical storage tank and each monitor or hose reel shall be within the limitations of the manufacturer's installation manual.

7.7.1.7 If multiple cylinders are used to pressurize the dry chemical agent containers, each cylinder shall be provided with a pressure gage and manual means of operation.

7.8 Dry Powder System Installed on Oil Loading Jetty Deck

7.8.1 General

Monitor and hose reel system specified in [IPS-E-SF-180](#) shall be pre-engineered and all local conditions and risk factors to be considered. The system shall cover the ship's manifold and the loading facilities of each berth. The design criteria shall be in accordance with [IPS-E-SF-180](#) Clause 11.

7.8.2 Regulator for dry chemical supply

7.8.2.1 Regulator shall be designed for inlet pressure of 197 bar and shall be set at reduced pressure of about 15 bar. Pressure regulators shall be provided with a spring loaded relief valve.

7.8.2.2 Check valve shall be provided at the end of nitrogen supply line.

7.8.3 Hose and hose reels

7.8.3.1 Single hose reel mounted on a suitable location shall be provided. The hose material shall be of non kink rubber type suitable for working pressure of at least 17 bar. The hose diameter shall be of not less than 25 mm and shall be suitable for tropical climate.

7.8.3.2 Hose reel shall be of manual rewind and straight through external fittings designed for minimum pressure drop.

7.8.4 Nozzles

7.8.4.1 Pistol grip type nozzle shall be provided with minimum effective range of 10 meters. The rate and duration of discharge, and consequently the amount of dry chemical shall be determined by the type and potential of the hazard.

7.8.5 Dry powder monitor

For fire protection of a potential high hazard in an open atmosphere such as Jetty deck, the dry powder monitors are suitable means to cover the ships manifold. The flow rate of monitor shall be in accordance with pre-engineered manufacturers designs specification.

7.8.6 Alarms

Visual and an audible alarms should be provided for jetty deck and wherever fixed system of dry chemical powder is installed.

7.9 Paint and Marking

7.9.1 Dry chemical extinguishing system shall be identified with permanently attached corrosion resistant nameplate and shall be located so that it is easily visible after installation. The nameplate shall contain the following informations:

- a) Manufacture's names or identifying symbol;
- b) Purchase order, tag number;
- c) Capacity of the tanks and operating pressure;
- d) Nitrogen cylinders capacity and pressure.

7.9.2 Marking plate shall also be permanently attached to most suitable location easily visible with wording "how to operate the extinguisher".

7.9.3 Paint and finishing shall be durable manufacture standard and shall adequately protect all pieces from their environment, corrosive, humid and climetical conditions. The equipment shall be painted with corrosion resistant primer and final coating for heat humid, corrosive and unshaded tropical climate. The finish paint should be of fire service red or as specified by purchaser.

7.10 Items to be Furnished by Manufacturers

7.10.1 Unit including dry chemical tank, nitrogen propellant system, manual or automatic action system devices, extinguishing dry powder and other ancillary equipment required for the system operation such as gas cylinder regulators.

7.10.2 Hose line and hose reel with mounting connection.

7.10.3 All operating devices which are necessary to match with alarms if the system is provided with alarm .

7.10.4 Discharge nozzles and monitors as specified.

7.10.5 Operation and maintenance instruction and spare part list.

7.10.6 System test procedures initial and periodic, including special tools required.

7.10.7 Bolts, nuts, washers, clamps, gaskets, etc., required for assembling and mounting. The supplied material shall be suitable for the environmental conditions stated in the specification.

7.11 Testing

7.11.1 The manufacturer shall quote all normal tests required as well as hydrostatic and simulation tests as specified hereunder.

7.11.2 All pressure containing parts of fire extinguisher shall be subjected to hydrostatic test at a

pressure of not less than 1½ times the design pressure of that part.

7.11.3 The system shall be given, prior to shipment an operational test simulating actual design operating conditions as closely as possible.

7.11.4 The manufacturer shall provide instructions for proper initial and periodical test procedures of extinguishing system without loss of extinguishing agent and any special tools required for such test.

7.11.5 Result of manufacturer's test as specified hereunder shall be provided in a letter certifying that the system was tested and met all requirements as specified and shall include:

- a) date of test
- b) purchase order, item number, tag number
- c) shipping destination
- d) equipment serial number
- e) test procedures
- f) officially certified summary of test observation results and conclusions. Any malfunctioning and/or system corrections shall be reported. In addition photographs of the system shall be furnished.

7.11.6 The manufacturer is sole responsible for the system meeting all requirements of these specification and application of codes.

7.11.7 The manufacturer shall provide instructions for the proper inspection and maintenance of the system in accordance with sources of this Standard.

7.12 Information to be Furnished by the Manufacturers

7.12.1 At quotation stage

The manufacturer shall furnish with his quotation the following information:

- 7.12.1.1** Manufacturer's name and equipment model number;
- 7.12.1.2** Comprehensive catalogs, technical data and description literature of the equipment offered;
- 7.12.1.3** An explicit statement of any deviation from this specification;
- 7.12.1.4** List of spare parts for commissioning and 2 years operation;
- 7.12.1.5** Preliminary dimensional drawing and description of operation with price list.

7.12.2 At ordering stage

The manufacturer shall furnish the Purchaser six weeks of the receiving purchasing order, the following information:

7.12.2.1 Five sets of drawing of the system and its components. Fabrication shall not start until after manufacturer receipt of approved drawing. Manufacturer shall supply one set of corrected drawings within 3 weeks after receipt of drawing which have been marked "Approved".

7.12.3 Manufacturer shall furnish the Purchaser the following information prior to the shipment:

- a) five copies of test certifications. This will be prerequisite for final acceptance and invoice approval;
- b) five sets of spare part lists for commissioning; two years operation and list of spare tools if specified;
- c) five sets of installation, maintenance and operating instructions including comprehensive

- trouble shooting instructions;
- d) five sets of certified outline drawings.

7.12.4 Spare charges

It is the responsibility of custodian or user to make sure that, spare recharges of dry chemical and nitrogen gas cylinders are available at the site.

7.13 Shipment

Each package and related equipment and materials shall be properly prepared for transit to prevent damages from handling, warehousing or shipping and shall be labeled to ensure that it is not lost on transit. In addition the following measures shall be taken:

- a) All external connections shall be protected by temporary closures to exclude dirt and other foreign matter.
- b) One package list to be included inside every package and/or packing list to be in metal enclosure attached to the package.
- c) Additional supports and packing shall be provided in order to prevent internal damages during transit for ocean transport. The equipment shall be crated in heavy duty container sealed with strong tape or metal bands. Precaution shall also be taken to protect the equipment, specially dry powder containers from possible marine exposures.

7.14 Guarantee

Manufacturer shall guarantee by letter of acceptance the satisfactory performance of the system in accordance with this specification. Manufacturer shall also guarantee to replace without charge any or all parts defective due to faulty material, design or poor workmanship for period of 12 months after installations or 13 months after date of shipment. Any alterations necessary to meet test or pass inspections shall be made at manufacturers expense.

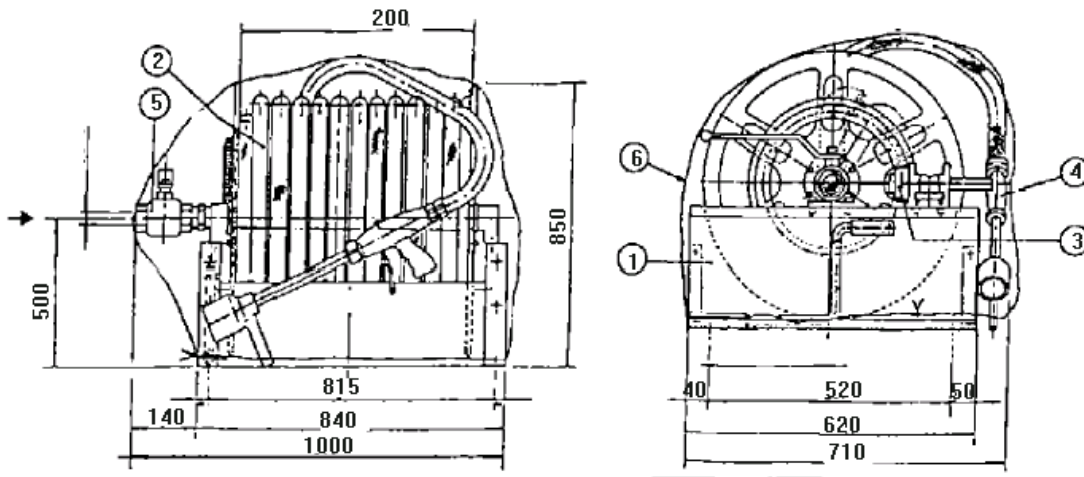

CHARACTERISTICS

Operating pressure:	18 bar
Test pressure:	27 bar
Design temperature:	-10°C ÷ +50°C
Weight:	90 kg
Hose characteristics:	
Diameter	32i x 44.5e

CONSTRUCTION MATERIAL:

Skid	: Galvanized steel
Drum	: Galvanized steel
Disks	: Galvanized steel
Rotation joint	: Bronze w/st. steel ball
Gun mod. PM-120:	Light alloy/brass
Hose Ø 1.¼	: Reinforced rubber

Length	46 m	Cover	: Vinyl
Type	SAE 100R3		
Max. operat. pressure	25 bar		
Bursting pressure	100 bar		

KEY

- 1. Hose reel
- 2. Hose
- 3. Conic couple for hose removing
- 4. Dry chemical gun Mod. PM-120.
- 5. Ball valve Φ 1.½ NPT F.
- 6. Red color cover

Quantity: N° 14 pieces

Tag N° : DC-8201

DRY CHEMICAL HOSE REEL STATION

Fig. 7

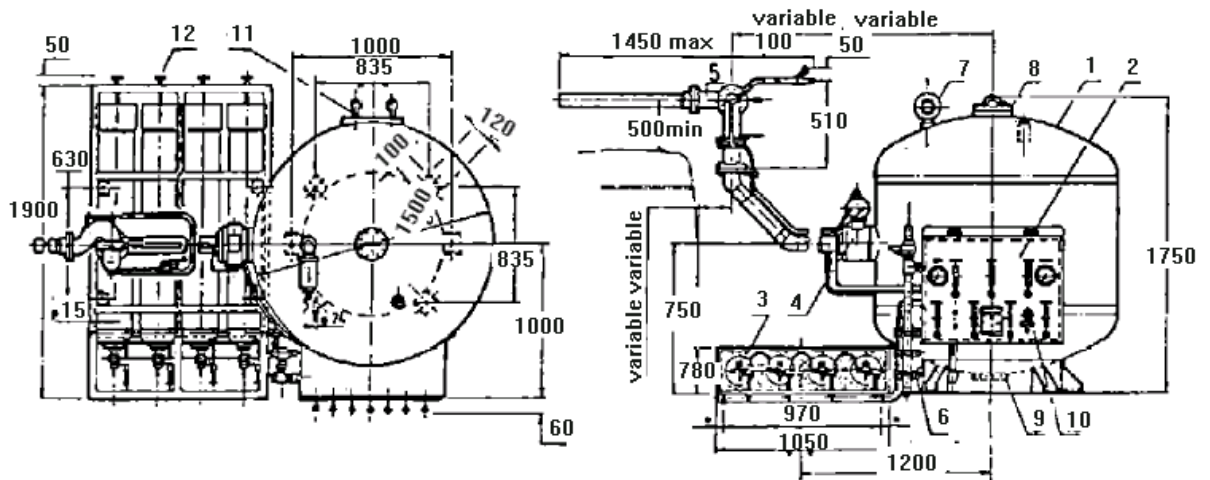

- 1. Dry chemical tank
- 2. Control panel
- 3. Nitrogen cylinder group with valves and pressure gage
- 4. Monitor pneumatic valve
- 5. Dry chemical monitor
- 6. Group of pressure reducers
- 7. Safety valve
- 8. Connection for filling tank with dry chemical
- 9. Connection for dry chemical discharge
- 10. Opening device for cylinder valves
- 11. Man hole
- 12. Cylinder fixing devices

DRY CHEMICAL UNIT

Fig. 8

SECTION 4**8. PERIODIC INSPECTION AND MAINTENANCE OF FIRE FIGHTING SYSTEMS, FIRE WATER DISTRIBUTION AND STORAGE FACILITIES****8.1 General**

Water is the most effective fire fighting source which is used in combination with other systems such as foam and sprinklers as well as by itself as the best cooling agent. Plants and complexes need a ring mains together with pumping station to transfer water in closed piping system. To ensure prompt readiness of the installation, certain elements of periodical inspections, maintenance and tests are required.

8.2 Weekly Check and Inspections**8.2.1 Source of water**

Source of water shall be checked at weekly interval to determine if the water reservoir has at least the capacity specified. The water supply shall be adequate and dependable.

8.2.2 Fire pump

Fire pump shall be kept ready to start at a moment notice. It shall be operated for at least five minutes every week at rated speed with water discharging through some convenient opening. The condition of bearings, suction pipe strainers, electrical equipment and prime mover is important to be checked. The pumps run shall be carried up to nearly full speed and pressure. The pump which is an important unit of protection if shows any significant reduction in the operating characteristics shall be repaired at the earliest time.

8.2.3 Diesel engine drive

Diesel engine pump shall be started at least once a week and run for minimum of 30 minutes to attain normal running temperature. They shall run smoothly at rated speed. The engine shall be kept clean, dry and well lubricated. The proper oil level shall be maintained in the crankcase. Oil shall be changed in accordance with manufacturers recommendations.

8.2.4 Batteries

Storage batteries shall be kept charged at all times. They shall be tested to determine the battery cells and amount of charge in batteries. Inspection shall determine that the charger is operating correctly, the water level in the battery is correct and the battery is holding its proper charge.

8.2.5 Fuel supply

The fuel storage tanks shall be kept as full as possible at all times, but never less than 50% of the tank capacity.

8.2.6 Temperature

Temperature of the pump room, pump house or area where engines are installed shall never be less than the minimum recommended by the engine manufacturer. The engine manufacturer's recommendation for water heater and oil heater in cold climate shall be followed.

8.3 Water Pipes and Hydrants

Routine maintenance should be planned for tests, repairs, leaks by operating the pumping units and discharging water from hydrants.

Periodic inspection should be made to all isolating valves to observe that these are kept locked in an "open" position.

Flow and pressure tests should be done by flow meter and checked that water capacity and pressure are according to the requirements. Fire hydrants shall be inspected monthly.

8.4 Hose Reels

Hose reels should be subject to regular inspection at least quarterly to ensure that the inlet valve, the automatic on/off valve, glands, tubing and shut-off nozzle are sound and free from leaks, and also to observe that the outlet of the nozzle is not chocked.

Some nozzles, in addition to giving a jet stream are also capable of producing a cone spray. In these cases correct functioning in each role should be checked.

Once a year the hose should be completely run out and subjected to operational water pressure to ensure that the hose is in good condition and that all couplings are water tight. A flow test should be carried out to see that a discharge of at least 30 liters/min. is achieved.

8.5 Annual Test of Fire Water System

8.5.1 Flow test

The annual flow test of the fire water system pump, drive, controller and transfer switch (if provided) shall be performed to determine their ability to continue to attain satisfactory performance at shut-off, rated and peak load. All alarms and automatic or remote starts shall operate satisfactory. Valves on suction line shall be checked to assure that they are fully open.

The annual test shall be performed by personnel trained in the operation and maintenance of fire pumps and fire water system. The test result shall be recorded.

8.5.2 Fire pump operation

The fire pumps shall be maintained in readiness for operation. After each test, the fire pump shall be returned to automatic or normal operation. All valves shall be returned to normal operation.

The fire pump room shall be clean, dry, orderly and free of miscellaneous storage. Access to this room shall be restricted.

8.5.3 Fire pump maintenance

A preventive maintenance program shall be established in accordance with the pump manufacturer's recommendations. Records shall be maintained on all work performed on the pump, drive, and controller.

8.6 CO₂ Gas Fire Extinguishing Systems

8.6.1 General

Manufacturer's recommended tests and inspection of CO₂ extinguishing system shall be carried out regularly by a competent person. This shall provide a procedure for the initial testing of the equipment as well as for periodic test inspection and maintenance of the system.

8.6.2 Tests and inspection

8.6.2.1 At least annually, all carbon dioxide systems and their component parts shall be thoroughly inspected for fault findings. The goal of this inspection and testing is not only to show that the system is in full operating condition, but also shall indicate the continuance of the condition until the next inspection.

8.6.2.2 Suitable discharge tests shall be made when any inspection indicates their advisability. Prior to testing, proper safety procedures shall be reviewed.

8.6.2.3 An inspection report with recommendations shall be filled by the responsible supervisor.

8.6.2.4 Between the regular service inspection or tests, the system shall be inspected visually or otherwise by approved or competent personnel, following an approved schedule.

8.6.2.5 At least semiannually, all high pressure cylinders shall be weighed and the date of the last hydrostatic test noted. If, at any time, a container shows a loss in net content of more than 10 percent it shall be refilled or replaced.

8.6.2.6 At least weekly the liquid level gages of low pressure containers shall be observed. If at any time a container shows a loss of more than 10 percent, it shall be refilled.

8.6.2.7 All system hoses including those used as flexible connectors shall be examined annually for damage. If visual examination shows any deficiency, the hose shall be replaced or tested as follows:

8.6.2.7.1 All system hoses including those used as flexible connectors shall be tested at 170 bar for high pressure systems, and at 60 bar for low pressure systems.

- a) Remove the hose from any attachment.
- b) Hoses for hand lines shall be checked for electrical continuity between couplings.
- c) The hose assembly is then to be placed in a protective enclosure designed to permit visual observation of the test.
- d) The hose must be completely filled with water before testing.
- e) Pressure then is applied at a rate-of-pressure rise to reach the test pressure within a minimum of one minute. Observations are then made to note any distortion or leakage.
- f) If the test pressure has not dropped and if the couplings have not moved, the pressure is released. The hose assembly is then considered to have passed the hydrostatic test if no permanent distortion has taken place.
- g) Hose assembly passing the test must be completely dried internally.
- h) Hose assemblies failing the above tests must be marked and destroyed. They shall be replaced with new assemblies.
- i) Hose assemblies passing the test shall be suitably marked with the date of the test on the hose.

8.6.2.8 Testing

All system hoses including those used as flexible connectors shall be tested every five years.

8.6.3 Maintenance

These systems shall be maintained in full operating condition at all times. Use, impairment, and restoration of this protection shall be reported promptly.

8.6.3.1 Any troubles or impairments shall be corrected at once by competent personnel.

8.6.4 Instruction

All persons who may be expected to inspect, test, maintain, or operate carbon dioxide fire extinguishing systems shall be thoroughly trained in the functions they are expected to perform.

8.7 Dry Chemical Fire Extinguishing Systems**8.7.1 General**

The continued capability for effective performance of a powder extinguishing system depends on performance and recording of maintenance and periodic testing. The need for preparation of a full proof programming should be considered.

8.7.2 Program of inspection

Same routine inspection as given in Clause 8.6.

8.7.2.1 Weekly

A visual check to observe no apparent damage to pipework and component parts and that all operating controls are properly set. Check that each protective seal on the nozzles is in place, operative and free from built-up of particles. Check pressure gage on stored or gas propellant containers and replace or rectify as recommended by manufacturer. Any container showing a pressure loss (adjusted for temperature) of more than 10% shall be refilled or replaced.

8.7.2.2 Monthly

Check that all personnel who may have to operate the equipment or system are properly trained and authorized to do so, and in particular, new employees have been instructed in its use.

8.7.3 Testing and maintenance schedule

In addition to any periodical inspection tests and maintenance of propellant gas containers, a service maintenance schedule for the system shall be established. Competent persons are responsible for implementation of maintenance schedule who should provide a signed dated report of the inspection and advising services carried out or needed. A suitable schedule is as follows.

8.7.3.1 Every 3 months

Test and service all electrical fire detection and alarm systems as recommended by manufacturers.

8.7.3.2 Every 6 months**8.7.3.2.1 Pipe work**

Externally examine pipework to determine its condition. Pressure test pipework when visual inspection indicates questionable strength due to corrosion or mechanical damage. It is essential that pipework be dried after every hydrostatic test.

8.7.3.2.2 Nozzles

Inspect and clean discharge nozzles and check for correct alignment. This is essential after use of the system and after each discharge test.

8.7.3.2.3 Valves

Check all control valves for correct manual function and automatic valve additionally for correct automatic operation.

8.7.3.2.4 Containers

Externally inspect powder and propellant containers.

8.7.3.2.5 Detection devices

Check and replace those parts as recommended by the manufacturer. This is particularly important in the case of fusible links.

8.7.3.2.6 Carbon dioxide propellant containers

Weigh the containers or use a liquid level indicator, if appropriate, to verify correct content of carbon dioxide. Replace, or refill those showing a loss of 10%.

8.7.3.3 Every twelve months

Check the powder for caking or lumping, the powder container should be opened and the powder examined to a depth of 150 mm by a tactile means. Replace all the powder by a fresh charge, if it shows any sign of caking or lumping. The removal of caked or lumpy material from powder by sieving or by machine designed for the purpose is not recommended. Such a procedure removes the symptoms temporarily but, since the basic cause has not been rectified, further caking or lumping is likely to occur. The use of sieve or machine to remove foreign bodies is also not recommended since their use for any purpose will involve considerable exposure to atmospheric humidity, increasing the risk of caking and the procedure itself has contamination risk.

The powder containers shall be inspected when convenient and more frequent inspections and checks may be appropriate in particular circumstances.

8.7.4 Replenishment of the system use

Powder and propellant used to replenish the system after use shall be of the type and specification for which the system is designed. Sufficient powder and propellant as spare to fill containers, if appropriate, should be held on the premises or should be available within 24 h. Powder refill charges should be stored in a dry environments in suitable containers.

8.7.5 Safety precaution

The system shall have a device to prevent discharge during system inspection and servicing.

8.8 Inspection and Maintenance of Foam Extinguishing System

8.8.1 Program of inspection

The responsible authority should establish a program of inspection and arrange a service and maintenance schedule, and keep record of the inspection and servicing.

The program should cover inspection of the system and components in accordance with manufacturer recommendations and a schedule for training of personnel in the use of the system. The program shall include instructions on the action to be taken in respect of faults. A suitable program is as follows:

a) Weekly

Carry out a visual check that there are no leaks or obvious damage to pipework, all operating controls and components are properly set and undamaged. The water supply is available and at the right pressure.

b) Monthly

Check that all personnel who may have to operate the equipment or system are properly trained and authorized to do so, and in particular that new employees have been instructed in its use.

8.8.2 Service and maintenance schedule

The schedule shall be carried out by a competent person who shall provide a signed, data report of the inspection and advising any rectification carried out or needed. A suitable schedule is as follows:

a) Every three months

Test and service all electrical detection and alarm systems.

b) Every six months**1) Foam producing equipment**

Inspect proportioning devices, their accessory equipment and foam makers for mechanical damage, corrosion, blockage of air inlets and correct manual function of all valves. This may necessitate the temporary isolation of the water main.

2) Pipework

Examine externally above-ground pipework to determine its condition and that proper drainage pitch is maintained. Hydraulically pressure test normally dry pipework when visual inspection indicates questionable strength due to corrosion or mechanical damage. The foam pipework shall be flushed and drained after use.

3) Strainers

Inspect and clean strainers. This is essential after use of the system and after any flow test.

4) Valves

Check all control valves for correct manual function and automatic valves additionally for correct automatic operation.

5) Tanks

Visually inspect all foam concentrate and foam solution tanks, without draining; check shipping containers of concentrate for evidence of deterioration.

c) Every twelve months**1) Foam system**

At least all of foam system shall be thoroughly inspected annually and checked for proper operation. This shall include performance evaluation of foam concentrate or premix solution quality or both.

2) Foam producing equipment

Proportioning devices, their accessory equipment and foam makers shall be inspected.

3) Piping

Above ground piping shall be examined to determine its condition. Pressure testing of normally dry piping shall be made when visual inspection indicate questionable.

4) Foam concentrate

At least annual inspection shall be made of foam concentrate and the tanks and storage containers for evidence of excessive sludging or deterioration. Test the foam concentrate of solution for changes in constitution or characteristics and the formation of sediment or precipitates. Correct any deterioration according to the manufacturer's recommendations.

8.8.3 Foam concentrate injection system

Foam concentrate injection systems should be so arranged that periodic tests and inspections can be made without discharging foam solution to the system piping in order to check operation of all components of the system. The system should be so arranged that tests can be performed with as little loss of foam concentrate as practical. Manufacturers test procedures should be closely followed.

8.8.4 Foam and fire equipment storage

Foam liquid concentrate and equipment shall be stored in an accessible location, not exposed to the hazard they protect. If hazard exist, they shall be in a non-combustible structure. If the storage facilities is provided off-premises, adequate transportation and loading facilities shall be assured.

Off-premises supplies shall be of proper type for the use of in the system of the given installation. At the time of a fire these off-premises supplies shall be accumulated in sufficient quantities before placing the equipment in operation, to insure uninterrupted foam production at the design rate for the required period of time. The amount of foam liquid concentrate shall be at least sufficient for the largest single hazard protected or group of hazards that are to be protected simultaneously.

Foam concentrates are subject to freezing and to deterioration from prolong storage at high temperature limitation, therefore the location of storage require special consideration to protect against container's exterior deterioration due to rusting or the causes.

8.8.5 Reserve supply

There shall be a readily available reserve supply of foam producing materials sufficient to meet design requirement in order to put the system back into service after operation. The supply should be available from outside source within 24 hours.

8.9 Twin Agents

The supply of foam liquid (AFFF) or (FFFP), expellant gas and dry chemical shall be kept on the premises or from an approved outside source within a short period of time, sufficient for one complete recharge.

This reserve supply of dry chemical shall be stored in constantly dry area and to be contained in metal drums or other containers that will prevent entrance of moisture even in small quantities, prior to charging the dry chemical vessel.

The dry chemical shall be carefully checked to determine that it is in free flowing powdery condition and the pressure or weight of the expellant gas container shall be checked as stipulated by the manufacturer to determine that it is above required minimum.

8.10 Fire Fighting Sprinkler Systems

8.10.1 General

This Section covers tests, inspection and supervisory service of sprinkler systems. Attention should be paid to certain conditions which may cause a serious loss which can be avoided by frequent inspection and careful maintenance of sprinkler systems. The causes of malfunctioning of the systems are:

- 1) insufficient water for various seasons;
- 2) unsatisfactory performance in which the fire may originate in unsprinkled area;
- 3) cases of faulty or defective or improperly adjusted dry pipe valves;
- 4) faulty building construction, obstruction to distribution of water;
- 5) hazards of occupancy too severe for sprinkler equipment. However if defects found and not corrected they will be the reasons for sprinklers' failure.

8.10.2 Routine inspections

8.10.2.1 Some of the more important points which will be helpful to those making inspections are given hereunder:

- a) Sprinklers must not be distracted by highly piled stock or materials nor by positions or walls which might prevent free and proper water distribution, no goods shall be stored within 0.5 m of sprinkler head and for highpiled combustible stock the clearance must be more than 1 m.
- b) Check that all sprinklers are of the proper temperatures rating.
- c) Make sure that sprinklers corroded are properly protected against corrosion.
- d) A supply of extra sprinklers the same type and rating are kept in a sprinkler service cabinet, so that faulty sprinklers can be replaced.
- e) A special sprinkler wrench should be provided and kept in the cabinet, to be used in the removal and installation of sprinklers.

8.10.2.2 Piping system and flow tests

- a) Make sure that general arrangements of feed mains and risers are satisfactory.
- b) The test valve should be operated at each inspection to make sure that there is free flow at good pressure. In dry system the test pipe is used to trip the dry pipe valve.
- c) Drain is usually provided at each alarm or dry pipe valve or at base of riser which makes water-flow test of sufficient volume possible to give a general idea of the condition of the

water, supply of mains and control valve;

d) When average or normal static pressure is known or determined, the drop in pressure with drain valve open can be noted and general flow condition studied or determined and if previous tests have shown a pressure drop, when the drain valve is opened, it will be apparent that there is some obstruction to the flow which should be removed or some other defects which should be located and remedied.

8.10.2.3 Control valves

a) All control valves should be numbered and listed giving locations, use or portion controlled. Underground or post indicator valves and cold weather valve shut off in winter, can be listed and there should be a plan showing valve locations.

b) All control valves should be readily accessible and unobstructed, so they can be closed promptly.

c) Valves should be examined frequently to see that they are open and in good operating condition, turn easily and do not leak.

d) Shift supervisors knowing the use and location of valves should be available whenever needed.

e) Valve pits should be kept reasonably dry and clean so that valves can be tested, examined and maintained in good condition.

f) The drip plug or the hole in the orifice plate should be inspected occasionally, if there is a leakage of water not coming from the alarm motor supply pipe, the installation being on water, the clock valve is not seating correctly, then the system must be closed down, drained and the clock valve and its seating cleaned and reset.

If the installation is on air setting, and water is leaking past either from the top or bottom of differential valve, the installation must be shut down and the differential valve and clock valve removed and cleaned. When checking the differential valve, give particular attention to the sealing of the top valve including the rubber washer.

g) Every six months remove the lock and strap from the main stop valve and run the valve up and down, grease the thread if necessary. Check that gland is water tight but do not overtighten the gland nuts. If leakage is persistent, it is better to renew the gland packing.

8.10.2.4 Alarm motor

The strainer on the alarm motor supply should be opened up at about six months intervals according to the slit that collect on it. Alarm connections and gong should be tested by means of by-pass provided for such purpose.

8.10.2.5 Alarm valves

a) Alarm check-valves and gongs shall be tested at least twice a year by inspector, testing the pipe at the top of the system.

b) Electric and water motor gongs shall be tested more frequently when there is a by-pass provided for testing gongs without disturbing the alarm check. Weekly or at least monthly tests are to be made. Electric gongs circuits and electrical supply can be tested frequently by means of a test switch. If system is connected to control station, notification should be given before tests are made.

8.10.2.6 Hangers

When inspecting hangers, make sure that there is no undue strain on the pipework, that pipes are not pulled so that they do not drain correctly and make sure that down pipes for drainage purpose are properly secured. This feature is specially important in dry pipe system, for water remaining in

pockets or low places is likely to freeze and cripple the system.

8.11 Water Spray System

8.11.1 General

Water spray systems require effective care and maintenance to assure that they will perform their purpose at the time of fire. Systems shall be serviced and tested periodically by personnel trained in this work. An inspection, service, test at regular interval shall be maintained.

Operating and maintenance instructions and lay-out shall be available or posted at maintenance control or at the plant fire control and selected personnel shall be trained and assigned to the task of operating and maintaining equipment.

At weekly or other frequent, regularly scheduled plant inspection the equipment shall be checked visually for obvious defects such as broken or missing parts, nozzle loading or other evidence of impaired protection.

8.11.2 Maintenance

8.11.2.1 Water supplies

Proper precautions shall be taken to ensure that water supplies are kept turned on and are in full operating condition at all times when hazard or exposure exists.

8.11.2.2 Strainers

Strainers except individual nozzle strainers shall be thoroughly inspected after each operation or flow test and cleaned if necessary. Routine inspection and cleaning shall be performed annually and more frequently if necessary, based on experience and local condition.

8.11.2.3 Piping

All piping shall be examined at regular interval to determine condition and proper drainage. Frequently inspections will depend upon local conditions and shall be at intervals of not more than a year.

8.11.2.4 Flow test

Flow tests of open head spray systems shall be made yearly or more frequently as determined from experience.

8.11.2.5 Control valve and devices

Control valves and automatic detection equipment shall be tested at least annually by qualified personnel.

8.11.2.6 Manual tripping devices and control valves shall be operated at least annually.

8.11.2.7 Where normally opened valves are closed following system operation or test, suitable procedures shall be instituted to insure that they are reopened and that the system is promptly and properly restored to full normal operating condition, main drain flow test shall be made after valves are opened.

8.11.2.8 Spray nozzles

All spray nozzles shall be inspected for proper positioning, external leak and corrosion cleaned if necessary at interval of not more than 12 months or more frequently if necessary. Based on experience, after each operation, spray nozzles should be dismantled and screen cleaned.

8.11.2.9 Flushing

The system shall be flushed at least annually. This shall be accomplished by:

- a) A flow test of the system, or,
- b) Flowing water from a suitable flushing connection of adequate size.

APPENDICES

APPENDIX A CARBON DIOXIDE

A.1 For fire extinguishing applications, carbon dioxide has a number of desirable properties. It is non-corrosive, nondamaging and leaves no residue to clean up after the fire.

It provides its own pressure for discharge through pipes and nozzles. Since it is a gas, it will penetrate and spread to all parts of a hazard. It will not conduct electricity and can therefore be used on live electrical hazards. It can be effectively used on practically all combustible materials except for a few active metals and metal hydrides, and materials such as cellulose nitrate, which contain available oxygen.

Under normal conditions carbon dioxide is an odorless gas with a density about 50 percent greater than the density of air. Many people insist they can detect an odor of carbon dioxide, but this may be due to impurities or chemical effects in the nostrils. Carbon dioxide is easily liquefied by compression and cooling. By further cooling and expansion it can be converted to the solid state.

The relationship between the temperature and the pressure of liquid carbon dioxide is shown on the curve given in Fig. A.1. It will be noted that as the temperature of the liquid increases, the pressure also increases. As the pressure increases, the density of the vapor over the liquid increases. On the other hand, the liquid expands as the temperature goes up and its density decreases. At 31°C the liquid and vapor have the same density, and of course the liquid phase disappears. This is called the critical temperature for carbon dioxide.

An unusual property of carbon dioxide is the fact that it cannot exist as a liquid at pressures below 5.2 bars. This is the triple point pressure where carbon dioxide may be present as a solid, liquid, or vapor. Below this pressure it must be either a solid or gas, depending on the temperature.

If the pressure in a storage container is reduced by bleeding of vapor, some of the liquid will vaporize and the remaining liquid will become colder. At 5.2 bars, the remaining liquid will be converted to dry ice at a temperature of 56°C. Further reduction in the pressure to atmospheric will lower the temperature of the dry ice to the normal 79°C .

The same process takes place when discharging liquid carbon dioxide to the atmosphere. A large portion of the liquid flashes to vapor with a considerable increase in volume. The rest is converted to finely divided particles of dry ice at -79°C. It is this dry ice or snow that gives the discharge its typical white cloudy appearance.

The low temperature also causes the condensation of water from the untrained air so that ordinary water fog tends to persist for a while after the dry ice has evaporated.

A.2 While carbon dioxide will not extinguish these fires it will not react dangerously with these materials or increase their burning rate. Carbon dioxide, if used in this type of situation in a total flooding system will provide protection for adjacent combustibles or can be successfully used if the reactive metals or hydride are first covered by another material. Examples of this later condition would be :

- a) Sodium stored or used under kerosene.
- b) Cellulose nitrate in solution of lacquer thinner.
- c) Magnesium chips covered with heavy oil.

Local application systems with attendant high velocity directed discharge should not be used.

(to be continued)

APPENDIX A (continued)

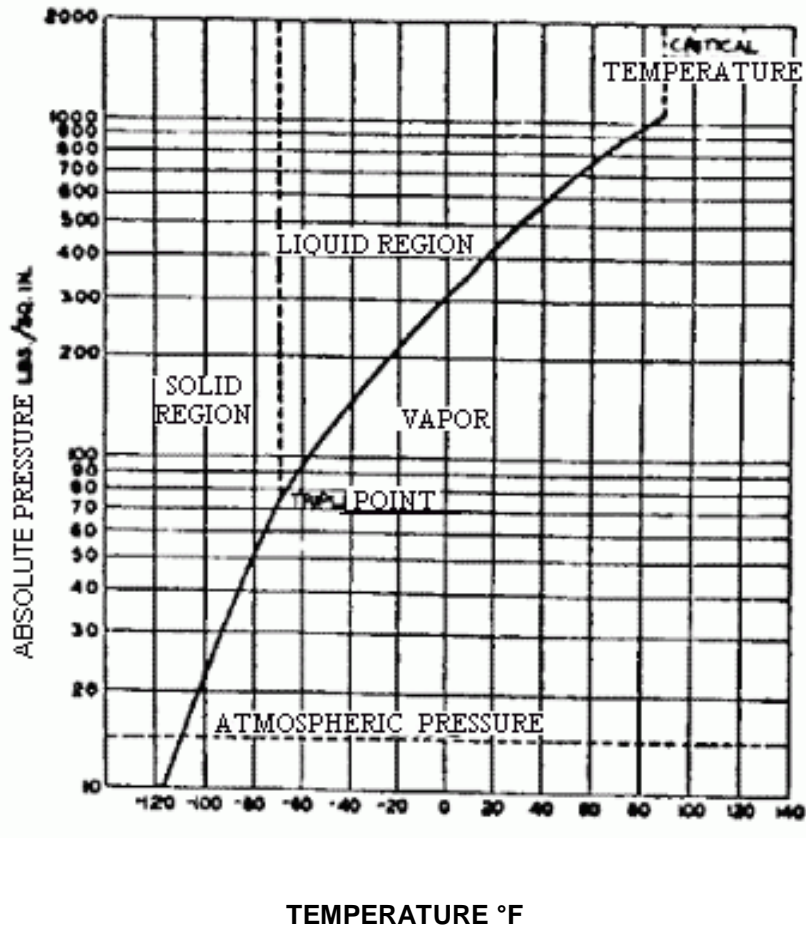

For SI Units: 1 psi = 0.0689 bars; °C = 5/9 (°F - 32)

Fig. A.1

Variation of pressure of carbon dioxide with change in temperature (Constant Volume). Below the critical temperature (31°C), carbon dioxide in a closed container is part liquid and part gas. Above the critical temperature it is entirely gas.

APPENDIX B
CHECK LIST FOR THE TASK OF CO₂ EXTINGUISHING SYSTEM FOR COMMISSIONING

- a) Check that the system is installed according to the relevant drawing and documents.
- b) Check that all detecting equipment function correctly, these are:

1) Fusible link system

Ensure that control cable lines are free and that operating control weights develop sufficient energy to operate container and for direction valve control mechanisms;

2) Pneumatic rate of rise system

Check with manometer to ensure correct breathing rate and leakfree capillary lines. Also apply heat to detectors to ensure correct operation and subsequent activation of control mechanisms;

3) In electrical detector systems, check electrical circuitry and supply voltages for integrity. Apply heat flame and smoke to detectors to check operation of control mechanisms.

- c) Operate manual release devices to ensure correct functioning.
- d) Check operation of all alarm devices.
- e) Check correct operation of all safety devices.
- f) Carry-out a test of CO₂ gas discharge using an adequate percentage of the total CO₂ capacity to check:
 - 1) that the direction valves, when shut hold leak back gas;
 - 2) feed pipes lead to the correct protected space;
 - 3) that no leak occur where equipment is fitted to pipework and at pipe fitting;

Note:

A partial discharge is appropriate for most installations, but for others a total discharge with measurement of carbon dioxide concentrations achieved may be desirable.

4) That pressure operated devices function correctly.

5) That where possible, discharge nozzles pass gas and that none are blocked.

- g) Ensure that containers are replaced and that all containers are filled with correct quantity of carbon dioxide.
- h) Check that nameplates and instruction plates are correctly worded.

B.1 Testing of systems. Manufacturer's and maintenance procedure should be guided by the following outline:

B.1.1 The system

- a) overall physical appearance;
- b) check if there have been any changes in the size or type of hazard protected;
- c) disarm system prior to test.

B.1.2 Supervised circuit

- a) exercise all functions;
- b) check all electrical or pneumatic supervisory circuits for proper operation.

B.1.3 Control panel

- a) exercise all functions;
- b) check supervision if applicable, of each circuit (including releasing devices) as recommended by the manufacturer.

(to be continued)

APPENDIX B (continued)**B.1.4 Power supply**

- a) check routing, circuit breakers, fuses, disconnects.

B.1.5 Emergency power

- a) battery condition;
- b) charger operation, check fuse;
- c) check automatic changeover;
- d) if generator, is it being properly maintained.

B.1.6 Detectors

- a) test each (All) using heat or smoke or manufacturer's approved test device (see [IPS-E-SF-260](#));
- b) electric:
 - 1) clean and adjust smoke detector and check sensitivity;
 - 2) check wiring condition.
- c) pneumatic:
 - 1) check tightness of tubing and operation of mercury checks, using manometer.

B.1.7 Time delay

- a) exercise;
- b) check time limit;
- c) check that timer will complete its cycle even though wiring between it and the detector circuit.

B.1.8 Alarms

- a) test for operation (audible and visual);
- b) check to see that warning signs are properly displayed.

B.1.9 Selector (directional) valves

- a) exercise;
- b) reset properly.

B.1.10 Release devices

- a) dampers, check for complete closure;
- b) doors; also check for any blocked open.

B.1.11 Equipment shutdown

- a) test;
- b) check adequacy (all necessary equipment included).

(to be continued)

APPENDIX B (continued)**B.1.12 Manual releases**

- a) mechanical:
 - 1) check pull, force, and length of pull required;
 - 2) operate and adjust all devices;
 - 3) tightness of connectors;
 - 4) condition of conduit;
 - 5) condition and operation of corner pulleys.
- b) Electric
 - 1) test;
 - 2) covers in place.
- c) pneumatic releases;
- d) accessibility during fire;
- e) separate main and reserve manual pulls requiring only one operation to obtain discharge of either main or reserve supply of gas;
- f) clearly mark and identify all manual releases.

B.1.13 Piping

- a) security, adequately supported;
- b) condition, any corrosion.

B.1.14 Nozzles

- a) orientation and orifice size unchanged from original design;
- b) clean;
- c) security;
- d) seals where needed.

B.1.15 Containers

- a) physical condition, any sign of corrosion;
- b) check the contents for weight by acceptable methods for each cylinder or low pressure tank. If the contents are more than 10 percent below the normal capacity, refilling is required. Proper operation of the liquid level gage should be verified;
- c) cylinders securely held in position;
- d) check hydrostatic test record;
- e) check cylinder connectors for integrity and condition;
- f) check weights and cables of mechanical release system;
- g) release devices, check for proper arrangement and security;
- h) explosive release devices, check replacement date and check condition.

(to be continued)

APPENDIX B (continued)**B.1.16 Test**

a) discharge tests should be recommended when there is any question about the adequacy of the system. A full discharge test is required for initial acceptance;

b) full discharge test recommended when cylinder hydrostatic test is required.

B.1.17 Return all parts of system to full service.

B.1.18 Certificate of inspection to owner.

APPENDIX C
SAFETY REQUIREMENTS

C.1 The discharge of carbon dioxide gas in enclosed spaces will be a hazard to personnel. Exposure to atmosphere containing about 5% carbon dioxide leads to shortness of breath and slight headache while at the 10% level may cause loss of consciousness. Fire extinguishing concentrations of carbon dioxide which is in excess of 30% especially near the point of discharge from total flooding or local application systems will cause almost immediate asphyxiation.

C.2 The steps and safeguards necessary to prevent injury or death to personnel in areas whose atmospheres will be made hazardous by the discharge of carbon dioxide may include the following:

- a)** Provision of adequate aiseways and routes of exit and keeping them clear at all times.
- b)** Provision of the necessary additional or emergency lighting, or both, and directional signs to ensure quick, safe evacuation.
- c)** Provision of alarms within such areas that will operate immediately upon activation of the system on detection of the fire, with the discharge of the carbon dioxide and the activation of automatic door closures delayed for sufficient time to evacuate the area before discharge begins.
- d)** Provision of only outward swinging, self-closing doors at exits from hazardous areas, and where such doors are latched , provision of panic hardware.
- e)** Provision of continuous alarms at entrance to such areas until atmosphere has been restored to normal.
- f)** Provision for adding an odor to the carbon dioxide so that hazardous atmospheres in such areas may be recognized.
- g)** Provision of warning and instruction signs at entrances to and inside such areas.
- h)** Provision for prompt discovery and rescue of persons rendered unconscious in such areas. This may be accomplished by having such areas searched immediately after carbon dioxide discharge stops by trained personnel equipped with proper breathing equipment. Those rendered unconscious by carbon dioxide can be restored without permanent injury by artificial respiration, if removed quickly from the hazardous atmosphere. Self-contained breathing equipment and personnel trained its use, and in rescue practices including artificial respiration, should be readily available.
- i)** Provision of instruction and drills of all personnel within or in the vicinity of such areas, including maintenance or construction people who may be brought into the area, to ensure their correct action when carbon dioxide protective equipment operates.
- j)** Provision of means for prompt ventilation of such areas. Forced ventilation will often be necessary. Care should be taken to really dissipate hazardous atmospheres and not merely move them to another location. Carbon dioxide is heavier than air.
- k)** Provision of such other steps and safeguards necessary to prevent injury or death as indicated by a careful study of each particular situation.
- l)** Where piping is not normally under pressure, it may not be bubble tight. However, where a slow discharge is involved, or if under continual pressure, bubble tightness should be a requirement. It is anticipated that full discharge testes will be waived by the relevant authority only under extremely unusual conditions. Factors such as extra cost, interruptions to production, or business operations are not considered to be valid reasons for waiver of full discharge tests.