

**ENGINEERING STANDARD**

**FOR**

**FOAM GENERATING AND PROPORTIONING SYSTEMS**

**ORIGINAL EDITION**

**MAY 1993**

**This standard specification is reviewed and updated by the relevant technical committee on Dec. 1998(1), July 2006(2) and Jan. 2014(3). The approved modifications are included in the present issue of IPS.**

**FOREWORD**

The Iranian Petroleum Standards (IPS) reflect the views of the Iranian Ministry of Petroleum and are intended for use in the oil and gas production facilities, oil refineries, chemical and petrochemical plants, gas handling and processing installations and other such facilities.

IPS is based on internationally acceptable standards and includes selections from the items stipulated in the referenced standards. They are also supplemented by additional requirements and/or modifications based on the experience acquired by the Iranian Petroleum Industry and the local market availability. The options which are not specified in the text of the standards are itemized in data sheet/s, so that, the user can select his appropriate preferences therein

The IPS standards are therefore expected to be sufficiently flexible so that the users can adapt these standards to their requirements. However, they may not cover every requirement of each project. For such cases, an addendum to IPS Standard shall be prepared by the user which elaborates the particular requirements of the user. This addendum together with the relevant IPS shall form the job specification for the specific project or work.

The IPS is reviewed and up-dated approximately every five years. Each standards are subject to amendment or withdrawal, if required, thus the latest edition of IPS shall be applicable

The users of IPS are therefore requested to send their views and comments, including any addendum prepared for particular cases to the following address. These comments and recommendations will be reviewed by the relevant technical committee and in case of approval will be incorporated in the next revision of the standard.

Standards and Research department

No.17, Street14, North kheradmand

Karimkhan Avenue, Tehran, Iran.

Postal Code- 1585886851

Tel: 021-88810459-60 & 021-66153055

Fax: 021-88810462

Email: [Standards@nioc.ir](mailto:Standards@nioc.ir)

**GENERAL DEFINITIONS:**

Throughout this Standard the following definitions shall apply.

**COMPANY:**

Refers to one of the related and/or affiliated companies of the Iranian Ministry of Petroleum such as National Iranian Oil Company, National Iranian Gas Company, National Petrochemical Company and National Iranian Oil Refinery and Distribution Company.

**PURCHASER:**

Means the "Company" where this standard is a part of direct purchaser order by the "Company", and the "Contractor" where this Standard is a part of contract documents.

**VENDOR AND SUPPLIER:**

Refers to firm or person who will supply and/or fabricate the equipment or material.

**CONTRACTOR:**

Refers to the persons, firm or company whose tender has been accepted by the company.

**EXECUTOR:**

Executor is the party which carries out all or part of construction and/or commissioning for the project.

**INSPECTOR:**

The Inspector referred to in this Standard is a person/persons or a body appointed in writing by the company for the inspection of fabrication and installation work.

**SHALL:**

Is used where a provision is mandatory.

**SHOULD:**

Is used where a provision is advisory only.

**WILL:**

Is normally used in connection with the action by the "Company" rather than by a contractor, supplier or vendor.

**MAY:**

Is used where a provision is completely discretionary.

**CONTENTS:**

**PAGE No.**

1. SCOPE .....	2
2. REFERENCES .....	2
3. DEFINITIONS AND TERMINOLOGY .....	3
4. UNITS .....	5
5. GENERAL .....	5
5.1 Abreviation .....	5
5.2 Foams.....	5
5.3 Expansion .....	5
5.4 Foam-Solution .....	6
6. LOW EXPANSION FOAM-TYPES AND REQUIREMENTS .....	6
6.1 System Description.....	6
6.2 Uses.....	7
6.3 Application Method.....	7
6.4 Potential Hazards .....	8
6.5 Compatibility with Other Extinguishing Media .....	8
6.6 Compatibility of Foam Concentrates .....	8
6.7 Foam Desturctiveness.....	8
6.8 System Design .....	9
6.9 Foam Supply System.....	9
6.10 Subsurface Foam Systems .....	12
6.11 Semi-Subsurface Systems .....	14
6.12 Pressure Storage of C <sub>4</sub> and Lighter Hydrocarbons.....	16
6.13 LNG and NGL Atmospheric Refrigerated Storage Tanks .....	16
6.14 Foam Monitors and Handlines.....	16
6.15 Foam Concentrate and Solution.....	19
6.16 Foam Quality .....	19
6.17 Dike Area Protection.....	20
6.18 Water Supplies and Pumps.....	20
6.19 Storage.....	21
6.20 Foam Concentrate Pumps .....	23
6.21 Hydrants.....	23
6.22 Foam Concentrate Facilities .....	24
6.23 Automatically Operated Systems.....	24
6.24 Detection and Alarm Equipment .....	24
7. FOAM SPRAY SYSTEMS .....	25
7.1 General.....	25
7.2 Discharge Rate.....	26
7.3 Duration of Discharge.....	26
7.4 Number and Location of Discharge Outlets.....	26
8. MEDIUM AND HIGH-EXPANSION FOAM SYSTEMS.....	26
8.1 General.....	26
8.2 Mechanisms of Extinguishment .....	28
8.3 Use and Limitations .....	28
8.4 Expansion .....	28
8.5 Application Method.....	29

---

8.6 System Design .....	29
8.7 Water, Foam Concentrate, and Air Supply .....	30
8.8 Foam Requirements for Medium Expansion Foam Systems .....	32
8.9 Total Flooding Systems.....	35
8.10 Local Application Systems .....	36
8.11 Portable Foam-Generating Devices .....	37
8.12 Safety Hazards .....	37
9. WETTING AGENTS .....	38
9.1 General.....	38
9.2 Uses.....	39
9.3 Limitations .....	39
9.4 Basic Requirements.....	40
9.5 Fire Department Supply Requirements .....	40
9.6 Fixed Systems .....	41

**APPENDICES:**

APPENDIX A CLASSIFICATION OF FOAM CONCENTRATES .....	42
APPENDIX B DETERMINATION OF APPLICATION RATE (MEDIUM EXPANSION) AND FOAM DISCHARGE RATE (HIGH EXPANSION).....	43
APPENDIX C .....	44
APPENDIX D FOAM CONCENTRATE STORAGE AND UNLOADING FACILITIES.....	45

**0. INTRODUCTION**

This Engineering Standard specifies various extinguishing systems to be appropriately designed and used for protecting and combating in different classes of fires and provides a degree of protection for life and property.

The intent of the engineering standard is to present the design consideration applicable to these systems. These Standards are divided into the following Titles.

<b>STANDARD CODES</b>	<b>TITLES</b>
<a href="#"><u>IPS-E-SF-120</u></a>	"Engineering Standard for Off-Shore Installations Fire-Fighting and Fire Protection"
<a href="#"><u>IPS-E-SF-140</u></a>	"Engineering Standard for Foam Generating and Proportioning Systems"
<a href="#"><u>IPS-E-SF-160</u></a>	"Engineering Standard for Co <sub>2</sub> Gas Fire Extinguishing Systems"
<a href="#"><u>IPS-E-SF-180</u></a>	"Engineering Standard for Dry Chemical Fire Extinguishing Systems"
<a href="#"><u>IPS-E-SF-200</u></a>	"Engineering Standard for Fire Fighting Sprinkler Systems"
<a href="#"><u>IPS-E-SF-220</u></a>	"Engineering Standard for Fire Water Distribution and Storage Facilities"
<a href="#"><u>IPS-E-SF-260</u></a>	"Engineering Standard for Automatic Detectors and Fire Alarm Systems"
<a href="#"><u>IPS-E-SF-300</u></a>	"Engineering Standard for Application of Breathing Apparatus in Safety and Fire Fighting"
<a href="#"><u>IPS-E-SF-504</u></a>	"Engineering Standard for Fire Fighting Vessels"
<a href="#"><u>IPS-E-SF-340</u></a>	"Engineering Standard for Fire Fighting Hose Box and/or shelter"

This Standard covers:

**"FOAM GENERATING AND PROPORTIONING SYSTEMS"**

**1. SCOPE**

This Standard specifies the requirements for foam producing and liquid concentrates employed for fire extinguishment, and gives designs of fixed and semi-fixed systems for applying low, medium and high expansion foam to fires in buildings, industrial plant and storage facilities.

It also covers:

- Classes of Foam Concentrates
- Foam Spray Systems
- Total Flooding Systems
- Local Application Systems
- Wetting Agents

**Note 1:**

**This standard specification is reviewed and updated by the relevant technical committee on Dec. 1998. The approved modifications by T.C. were sent to IPS users as amendment No. 1 by circular No. 41 on Dec. 1998. These modifications are included in the present issue of IPS.**

**Note 2:**

**This standard specification is reviewed and updated by the relevant technical committee on July 2006. The approved modifications by T.C. were sent to IPS users as amendment No. 2 by circular No. 302 on July 2006. These modifications are included in the present issue of IPS.**

**Note 3:**

**This standard specification is reviewed and updated by the relevant technical committee on Jan. 2014. The approved modifications by T.C. were sent to IPS users as amendment No. 3 by circular No. 413 on Jan. 2014. These modifications are included in the present issue of IPS.**

**2. REFERENCES**

Throughout this Standard the following dated and undated standards/codes are referred to. These referenced documents shall, to the extent specified herein, form a part of this standard. For dated references, the edition cited applies. The applicability of changes in dated references that occur after the cited date shall be mutually agreed upon by the Company and the Vendor. For undated references, the latest edition of the referenced documents (including any supplements and amendments) applies.

**BSI (BRITISH STANDARD INSTITUTION)**

- |                                   |   |
|-----------------------------------|---|
| English version of DIN EN 13565-1 | “Fixed Firefighting Systems – Foam Systems”<br>Part 1: Requirements and Test Methods for Components |
| BS 13565                          | “Fixed Firefighting Systems- Foam Systems”<br>Part 2: Design, Construction and Maintenance          |

**NFPA (NATIONAL FIRE PROTECTION ASSOCIATION)**

- |         |   |
|---------|---|
| NFPA 11 | “Standard for Low-, Medium-, and High-Expansion Foam” |
| NFPA 18 | “Standard on Wetting Agents”                          |

### 3. DEFINITIONS AND TERMINOLOGY

#### 3.1 Alcohol-Resistant Foam Concentrate

A concentrate used for fighting fires on water-soluble materials and other fuels destructive to regular, AFFF, or FFFP foams, as well as for fires involving hydrocarbons.

#### 3.2 Aqueous Film-Forming Foam Concentrate (AFFF)

A concentrate based on fluorinated surfactants plus foam stabilizers to produce a fluid aqueous film for suppressing hydrocarbon fuel vapors and usually diluted with water to a 1 percent, 3 percent, or 6 percent solution.

#### 3.3 Combustible Liquid

A liquid that has a closed-cup flash point at or above 37.8°C (100°F).

#### 3.4 Concentration

The percent of foam concentrate contained in a foam solution, usually expressed as a percentage by volume.

#### 3.5 Educator (Inductor)

A device that uses the venture principle to introduce a proportionate quantity of foam concentrate into a water stream. The pressure at the throat is below atmospheric pressure and will draw in liquid from atmospheric storage.

#### 3.6 Expansion

The ratio of air to water in the foam. A measure of the volume of foam produced for each volume of foam solution used.

#### 3.7 Flammable Liquid

A liquid that has a closed-cup flash point that is below 37.8°C (100°F) and a maximum vapor pressure of 2068.6 mm Hg (40 psia) at 37.8°C (100°F).

#### 3.8 Fluoroprotein Foam Concentrate

A concentrate very similar to protein-foam concentrate but with a synthetic fluorinated surfactant additive.

#### 3.9 Foam

A stable aggregation of bubbles of lower density than oil or water.

#### 3.10 Foam Concentrate

A concentrated liquid foaming agent as received from the manufacturer.

#### 3.11 Foam Solution

A homogeneous mixture of water and foam concentrate in the proper proportions.



**3.12 High Expansion Foam**

Foam which has an expansion ratio greater than 200:1

**3.13 Low Expansion Foam**

Foam which has an expansion ratio not greater than 20:1

**3.14 Medium Expansion Foam**

Foam which has an expansion ratio greater than 20:1 but not greater than 200:1

**3.15 Medium- and High-Expansion Foam Concentrate**

A concentrate, usually derived from hydrocarbon surfactants, used in specially designed equipment to produce foams having foam-to-solution volume ratios of 20:1 to approximately 1000:1.

**3.16 Premixed Foam Solution**

Is produced by introducing a measured amount of foam concentrate into a given amount of water in a storage tank.

**3.17 Proportioning**

The continuous introduction of foam concentrate at the recommended ratio into the water stream to form foam solution.

**3.18 Protein Foam Concentrate (Protein)**

Concentrate consisting primarily of products from a protein hydrolysate, plus stabilizing additives and inhibitors to protect against freezing, to prevent corrosion of equipment and containers, to resist bacterial decomposition, to control viscosity, and to otherwise ensure readiness for use under emergency conditions.

**3.19 Surfactant**

Also known as syndet or detergent foam.

**3.20 Wetting Agent**

A chemical compound which when added to water in proper quantities, materially reduces its surface tension, increases its penetrating and spreading abilities and can also provide emulsification and foaming characteristics.

**3.21 Wet Water**

Water to which a compatible wetting agent has been added.

### 3.22 Wet Water Foam

An admixture of wet water with air to form a cellular structure foam which breaks down rapidly into its original liquid state at temperatures below the boiling point of water at a rate directly related to the heat to which it is exposed in order to cool the combustible on which it is applied.

## 4. UNITS

This Standard is based on International System of Units (SI), as per [IPS-E-GN-100](#) except where otherwise specified.

## 5. GENERAL

### 5.1 Abbreviation

AR	Alcohol Resistant
P	Protein
FP	FluoroProtein
FFFP	Film Forming FlouroProtein
AFFF	Aqueous Film Forming Foam

### 5.2 Foams

**5.2.1** Extinguishing by the exclusion of air (blanketing) and by its cooling properties, prevention or ignition of ignition or reignition by blanketing. Foam extinguishment is applicable to oils, fats and highly flammable liquids.

**5.2.2** Foam for fire protection is an aggregate of air filled bubbles formed from aqueous solution and is lower in density than lightest flammable liquids. It is principally used to form a coherent floating blanket on flammable and combustible liquids lighter than water and prevents or extinguishes fire by excluding air and cooling the fuel. Reignition is excluded by suppression of flammable vapors. It adheres to surfaces and provides protection from adjacent fires. Foam is supplied by fixed pipe systems or portable foam generating units.

**5.2.3** All fixed foam installations should be designed to reduce time lag in charging service lines to a minimum, and provision made for draining all services after use.

**5.2.4** Subsurface foam injection facilities shall be provided for fixed roof tanks.

### 5.3 Expansion

Foams are classified by their expansion ratio (expansion), the ratio of the volume of the made foam to the volume of the solution from which it is made, as follows.

- a)** Low expansion foams, with expansions between 1 and 20, are intended primarily for application to the surface of flammable liquid fires.
- b)** Medium expansion foams, with expansions between 21 and 200, are intended for surface application or for application to fires which require a certain depth of foam to obtain coverage, e.g. up to depths of 4 m.
- c)** High expansion foams, with expansions between 201 and 1000, are intended for filling enclosures within which a number of fires are burning at different levels up to 10 m.

## 5.4 Foam-Solution

**5.4.1** Protein foams are made from concentrates based on proteinaceous products alone and with the addition of fluorinated additives to give fluoro protein foams. Another development is a mixture of hydrocarbon and fluorinated surfactant materials with stabilizers to form aqueous filmforming foam (AFFF) type concentrates. These are used for the extinction of fires in hydrocarbons and other water immiscible flammable liquids.

**5.4.2** Modifications of fluoroprotein and AFFF foams have been developed that are suitable for use on fires in watermiscible flammable liquids, e.g. alcohols and ketones. These are the alcohol resistan (AR) foams or general purpose foams. Medium expansion foams can be made from low expansion foam concentrates, but it is more usual to make them from a surfactant concentrate based on ammonium lauryl ether sulphate. High expansion foams are also made from this concentrate.

**5.4.3** The use of low expansion foams is restricted largely to the extinction of flammable liquid fires, but there is no reason why they should not be applied to solid fuels also, provided adequate coverage can be obtained to exclude air as much as possible. In practice, low expansion foams may either be applied to the surface of a burning liquid (surface application), or beneath the surface so that the foam stream floats to the surface and spreads to form a protective layer or blanket upon it (sub-surface application). The first method is the more common, and can be used against spill fires, fires in banded areas, fuel tanks, etc., using the appropriate equipment.

**5.4.4** Medium expansion foams are generally applied to the surface of flammable liquid fires, either by hand-held foam-making branches, or from fixed foam makers. This medium can also be used effectively on solid fuel fires, or 'mixed' fires of solid and liquid combustibles. Typical examples would be on a fire in a gas turbine driven generating set, a fuel fire in the engine room of a ship, heat-treatment baths, or places where fuel spillages can occur, e.g. in pit areas, in garages or in overhaul shops. High expansion foams are similar in action to medium expansion foams, but they require generators in which air is supplied by a fan, in order to achieve the rate of flow necessary for their production. They work by blanketing or smothering a fire, but the degree of cooling available is much less than for medium expansion foams, due to their lower water content. They can, however produce much greater foam depths of at least 10m, and can therefore smother a fire in goods stored on high racks. For this, the depth of the foam needs to increase rapidly in order to match, or overtake, the upward rate of development of the fire.

## 6. LOW EXPANSION FOAM-TYPES AND REQUIREMENTS

### 6.1 System Description

**6.1.1** A system consists of an adequate water supply, a supply of foam concentrate, suitable proportioning equipment, a proper piping system, foam makers, and discharge devices designed to adequately distribute the foam over the hazard. Some systems may include detection devices.

**6.1.2** These systems are of the open outlet type in which foam discharges from all outlets at the same time, covering the entire hazard within the confines of the system.

**6.1.3** Self-contained systems are those in which all components and ingredients, including water, are contained within the system. Such systems usually have a water supply or premix solution supply tank pressurized by air or inert gas. The release of this pressure places the system into operation.

**6.1.4** There are four basic types of systems:

- a) Fixed
- b) Semifixed
- c) Mobile
- d) Portable

### 6.1.5 Fixed system

These are complete installations piped from a central foam station, discharging through fixed delivery outlets to the hazard area to be protected. Any required pumps are permanently installed.

### 6.1.6 Semifixed systems

a) The type in which the hazard is equipped with fixed discharge outlets connected to piping that terminates at a safe distance.

The fixed piping installation may or may not include a foam maker. Necessary foam producing materials are transported to the scene after the fire starts and are connected to the piping.

b) The type in which foam solutions are piped through the area from a central foam station, the solution being delivered through hose lines to portable foam makers, such as monitors, foam towers, hose lines, etc.

### 6.1.7 Mobile systems

This includes any foam producing unit that is mounted on wheels, and that is self-propelled or towed by a vehicle. These units should be connected to a suitable water supply or utilize a premixed foam solution.

### 6.1.8 Portable systems

The type in which the foam producing equipment and materials, hose, etc., are transported by hand.

## 6.2 Uses

6.2.1 The requirements of this section apply to low expansion foam and foam systems suitable for extinguishing fires on a generally horizontal flammable and combustible liquid surface.

6.2.2 Extinction is achieved by the formation of a blanket of foam over the surface of the burning liquid. This provides a barrier between the fuel and air, reducing the rate of emission of flammable vapors to the combustion zone, and cooling the liquid.

6.2.3 Low expansion foam is not generally suitable for the extinction of running fuel fires, e.g. fuel running from a leaking container or from damaged pipework or pipejoints. However, low expansion foam can control any pool fire beneath the running fire which is then extinguished by other means.

6.2.4 Low expansion foam, except for the alcohol resistant type, is generally not suitable for use on foam destructive liquids which cause rapid breakdown of the foam.

6.2.5 Low expansion foam is not suitable for use on fires involving gases or liquefiable gases with boiling points below 0°C, or cryogenic liquids. The advice of the manufacturer should, therefore, be sought for this application.

## 6.3 Application Method

Low expansion foams shall be applied:

- a) Gently to the surface of the burning liquid (as pourer or semi-subsurface systems); or
- b) Forcefully to the surface of the burning liquid (as in monitor and branch pipe systems); or
- c) Below the surface so that they float to the surface under their own buoyance (as in subsurface systems).

## 6.4 Potential Hazards

**6.4.1** Foam systems shall include provision to minimize the danger when foam is applied to liquids above 100°C, energized electrical equipment or reactive materials.

**6.4.2** Since all foams are aqueous solutions, where liquid fuel temperatures exceed 100°C they are ineffective and, particularly where the fuel depth is considerable (e.g. tanks) can be dangerous in use.

**6.4.3** The foam and drainage of the water from the foam can cool the flammable liquid but boiling of this water may cause frothing or slop-over of the burning liquid. Boil-over, which may occur even where foam is not applied, is a more severe and hazardous event. Large scale expulsion of the burning contents of a tank is caused by the sudden and rapid boiling of water in the base of the tank or suspended in the fuel. It is caused by the eventual contact of the upper layer of liquid fuel in the tank, heated to above 100°C by the fire, with the water layer. Particular care should be taken when applying foam to high viscosity liquids, such as burning asphalt or heavy oil, above 100°C.

**6.4.4** Because foams are made from aqueous solutions they are dangerous to use on materials which react violently with water, such as sodium or potassium, and should not be used where they are present. A similar danger is presented by some other metals, such as zirconium or magnesium, only when they are burning.

**6.4.5** Low expansion foam is a conductor and should not be used on energized electrical equipment, in situations where this would be a danger to personnel.

## 6.5 Compatibility with Other Extinguishing Media

**6.5.1** The foam produced by the system shall be compatible with any media provided for application at or about the same time as foam.

**6.5.2** Certain wetting agents and some extinguishing powders are incompatible with foams, causing a rapid breakdown of the latter. Only media that are substantially compatible with a particular foam should be used in conjunction with it.

**6.5.3** Use of water jets or sprays shall adversely affect a foam blanket. They should not be used in conjunction with foam unless account is taken of any such effects.

## 6.6 Compatibility of Foam Concentrates

Foam concentrate (or solution) added or put into a system shall be suitable for use and compatible with any concentrate (or solution) already present, in the system. Foam concentrates or foam solutions, even of the same class, are not necessarily compatible, and it is essential that compatibility be checked before mixing two concentrates or premixed solutions.

## 6.7 Foam Destructiveness

**6.7.1** For the purposes of this standard when considering foam destructiveness, flammable and combustible liquids are considered as falling into two groups:

- a) Hydrocarbons, and those non-hydrocarbon liquids which are not more foam destructive than hydrocarbons;
- b) Foam destructive liquids, which are generally water soluble, and which are much more foam destructive than hydrocarbons.

**6.7.2** Special types of concentrates are used for foam destructive liquids. Higher rates of application are specified for foam destructive liquids than for hydrocarbons and it is usually essential to use gentle application methods.

**6.7.3** The degree of foam destructiveness varies, however, and isopropyl alcohol, butyl alcohol, isobutyl methyl ketone, methyl methacrylate monomer and mixtures of water-miscible liquids in general may require higher application rates. \*

\* **The preferred names for isopropyl alcohol, butyl alcohol and isobutylmethyl ketone are propane 2-0l, butan-1-0l and 4- methylpentane. 2-one respectively.**

**6.7.4** Protection of products such as amines and anhydrides which are particularly foam destructive requires special consideration.

## **6.8 System Design**

### **6.8.1 General**

The system shall be designed to suit the particular hazard. The following should be considered:

- a) Full details of the flammable liquid, its storage, handling and location.
- b) The most suitable class of foam concentrate and concentration.
- c) The most suitable solution application rate.
- d) The most suitable equipment for making and delivering foam.
- e) Required system operation time.
- f) Quantity of foam concentrate required for extinction.
- g) The most suitable proportioning method(s).
- h) Pipework sizes and pressure losses.
- i) Water supply quantity, quality and pressure.
- j) Method of system operation and any fire or gas detection equipment required.
- k) Any special considerations, such as the use of electrical equipment in areas where flammable vapors may be present.
- l) Reserve foam concentrate supply.
- m) Drainage and bunds.
- n) Environmental conditions.

## **6.9 Foam Supply System**

### **6.9.1 Fixed roof tanks**

**6.9.1.1** Fires on this type of tank shall be extinguished with the aid of mobile foam monitors fed by a fire truck, supplying a quantity of foam solution to 4.1 Lit/min.m<sup>2</sup> of liquid surface to be extinguished. The foam concentrate storage capacity and quantity of monitors and fire trucks shall be determined in relation to the diameter of the tank.

**6.9.1.2** Fixed foam equipment on tankage is required by means of base injection equipment on fixed roof tanks and the dry rising main to the gagers platform on some floating roof tanks for fighting rim fires. For subsurface foam systems (Base Injection) see Clause 6.10.

## 6.9.2 Floating roof tankage

**6.9.2.1** Fire protection for floating roof tanks is based on rim fires only, because this type of tank has an excellent fire record and if maintained properly the possibility of a large fire is remote. Overfilling the tank shall be avoided under all circumstances.

A 'high alarm' and an independent 'high-high alarm' are installed to warn the plant operating personnel before over filling levels are reached. When required, the tank filling valve(s) can be made to close automatically by the level alarm signal. Where access is provided and situations permit, rim fires shall be fought from the wind girder, otherwise they will be fought from the gager's platform or from ground level.

**6.9.2.2** For tanks less than 48 m diameter a 100 mm single dry rising main should be provided from outside the bund to the gager's platform, terminating in a fixed foam pourer/generator and in two 65 mm feed hose couplings, complete with isolating valves and air vents for quick expulsion of entrapped air. The riser is provided to enable foam solution to be pumped up to the gager's platform and allow foam to be produced either via the fixed foam pourer or at a branch pipe on the end of a hose.

**6.9.2.3** For tanks 48 m diameter and above, the 100 mm dry riser shall terminate in a 100 mm ring main to follow the line of the wind girder, with single, valved hose connections at approximately 46 m intervals. Foam dams will be provided as required for such tanks if fitted with pantograph seals. (See Fig. 1)

Although experience with a number of fixed foam pourers has been satisfactory, the system requires the immediate attention of a fully manned fire-fighting vehicle, as soon as possible after a fire has been detected.

**6.9.2.4** A rim plate shall be welded to the floating roof to form a foam dam. (See Fig. 2) Based on a rim plate of about 0.3 m high at a distance of 1m from the tank wall, the content of the foam dam in dm<sup>3</sup> is approximately 1000 D

**where:**

**D** = diameter in m of the largest floating roof tank.

Assuming an expansion factor of 7, the required foam solution in dm<sup>3</sup> is:

$$\frac{1000D_1}{7} \quad 150D$$

**6.9.2.5** A detector alarm system within the tank rim seal with the alarm indication terminating in a manned control room should be installed.

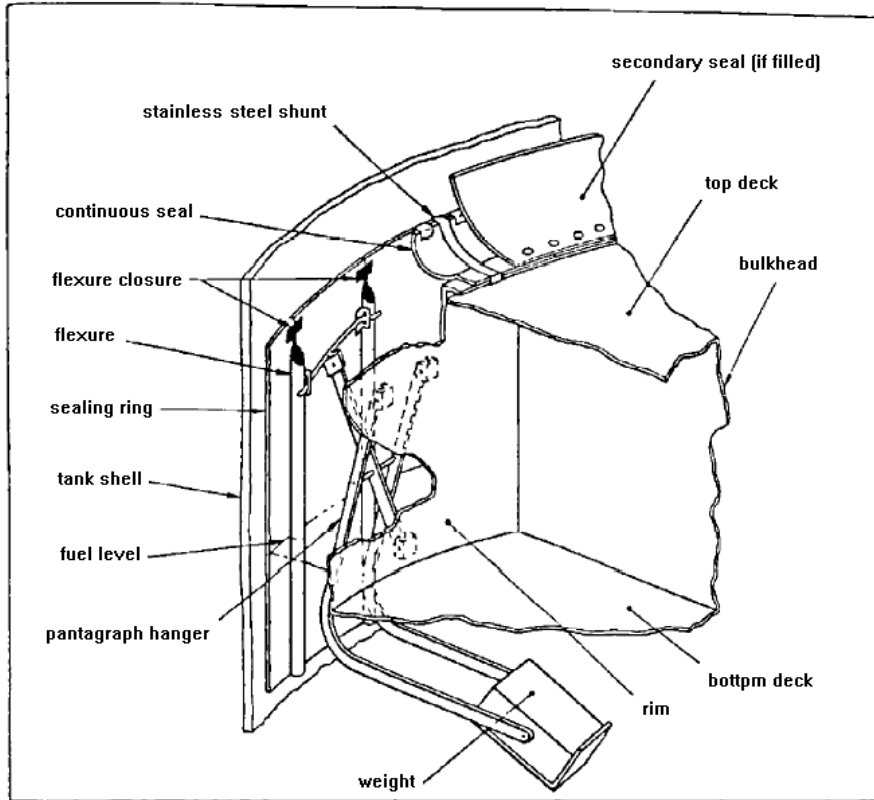

**TYPICAL PANTOGRAPH SEAL**  
Fig. 1

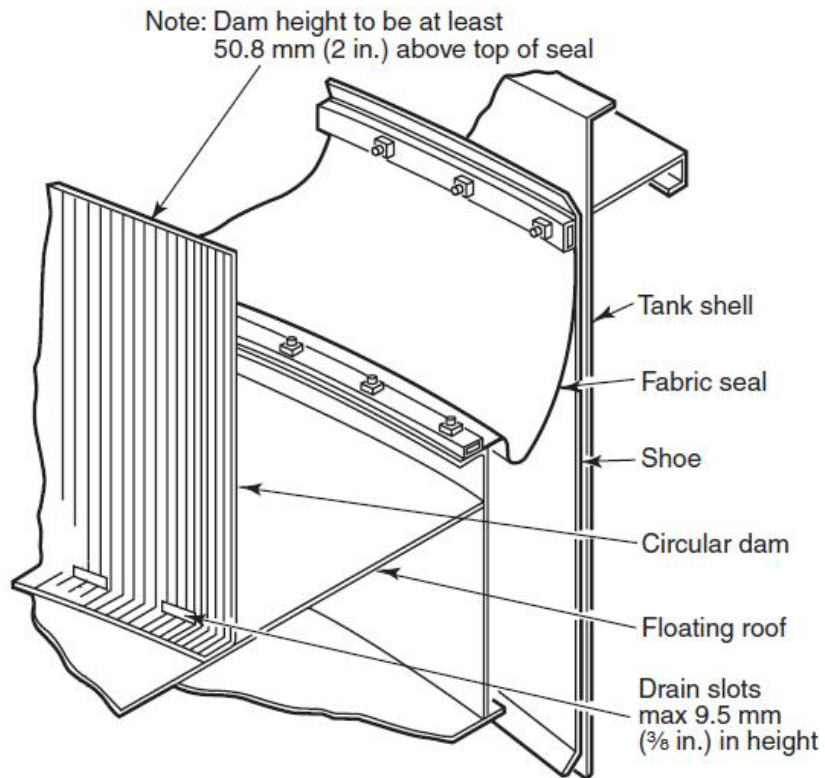

**TYPICAL FOAM DAM FOR FLOATING ROOF TANK PROTECTION**  
Fig. 2



## 6.10 Subsurface Foam Systems

### 6.10.1 General

**6.10.1.1** The requirements of this clause are applicable to systems used for the protection of fixed roof storage tanks containing low viscosity hydrocarbon liquids, in which foam is injected (through a product line or through a special foam line) at the base of the tank and rises to the surface through the liquid in the tank.

**6.10.1.2** Experience with fuel storage tank fire fighting has shown that the main problems are operational, i.e., difficulty in delivering the foam relatively gently to the fuel surface at an application rate sufficient to effect extinguishment. A properly engineered and installed subsurface foam system offers the potential advantages of less chance for foam-generation equipment disruption as a result of an initial tank explosion or the presence of fire surrounding the tank, and the conduct of operations a safe distance from the tank. Thus, opportunity for establishing and maintaining an adequate foam application rate is enhanced.

**6.10.1.3** The typical arrangement shown in Figure 3 should be used where it can be ensured that the isolating stop valve at the base of the tank is normally open.

**6.10.1.4** Where a subsurface system has been installed for tank protection, arrangements may be made to allow the system to discharge into the surrounding bund, in order to supplement other methods of bund protection. Subsurface systems are not suitable for foam destructive fuels or for some high viscosity fuels. Subsurface systems are not used for the primary protection of floating roof tanks because the roof will prevent complete foam distribution. Only FP, FFFP and AFFF foams which will tolerate severe mixing with fuel are suitable for subsurface application. Protein foam is not suitable. Subsurface systems are sometimes called base injection systems.

**6.10.1.5** Consideration should be given to the following when selecting one of the variations of this type of system.

- a) The total foam output reaches the tank.
- b) With large tanks, inlets are suitably distributed to allow even foam spread over surface of the fuel.
- c) The system is essentially simple and, being at ground level, is less likely to be damaged by fire or explosion than overhead systems.
- d) The rising foam stream induces vertical circulation of cold fuel from the base of the tank to the burning surface dissipating hot fuel layers at the burning surface and assisting extinction.
- e) Essential equipment and operating personnel can be located at a safe distance from the fire.
- f) The system is easy to check and maintain.
- g) The high back-pressure foam generator and foam solution supply should be fixed or portable for connection to foam inlet pipes or product line connections outside the bunded area.
- h) A high back-pressure foam generator is used to produce foam at a pressure sufficient to overcome the high pressure head of fuel as well as all frictional losses in the foam pipework. Frictional losses with foam differ from those with foam solution.
- i) Where the foam is injected through the product line, it is essential that automatic closure fire valves are not fitted.

### 6.10.2 Discharge rate

The discharge rate (in L/min) shall be not less than four times the area of the tank (in m<sup>2</sup>). With same fuels, where there has been a long preburn prior to the application of foam, a hot zone exist

near the burning surface at temperatures in excess of 100°C. In order to avoid frothing and slop-over, continuous application of foam should be avoided in the initial stages. Intermittent application of the foam can induce circulation of the fuel in the tank, thereby bringing the cooler layers of fuel to the surface. The foam injected intermittently will disperse without sufficient steam formation to produce frothing. The rates of foam discharge from each outlet should be approximately equal.

**6.10.3 Duration of discharge**

The minimum duration of discharge of systems discharging at the minimum rate specified in 6-10-2 shall be as given in Table 4 of this Standard. The minimum duration of discharge of systems discharging at higher than the minimum rate shall be reduced in proportion but shall be not less than 70% of the time given in Table 4.

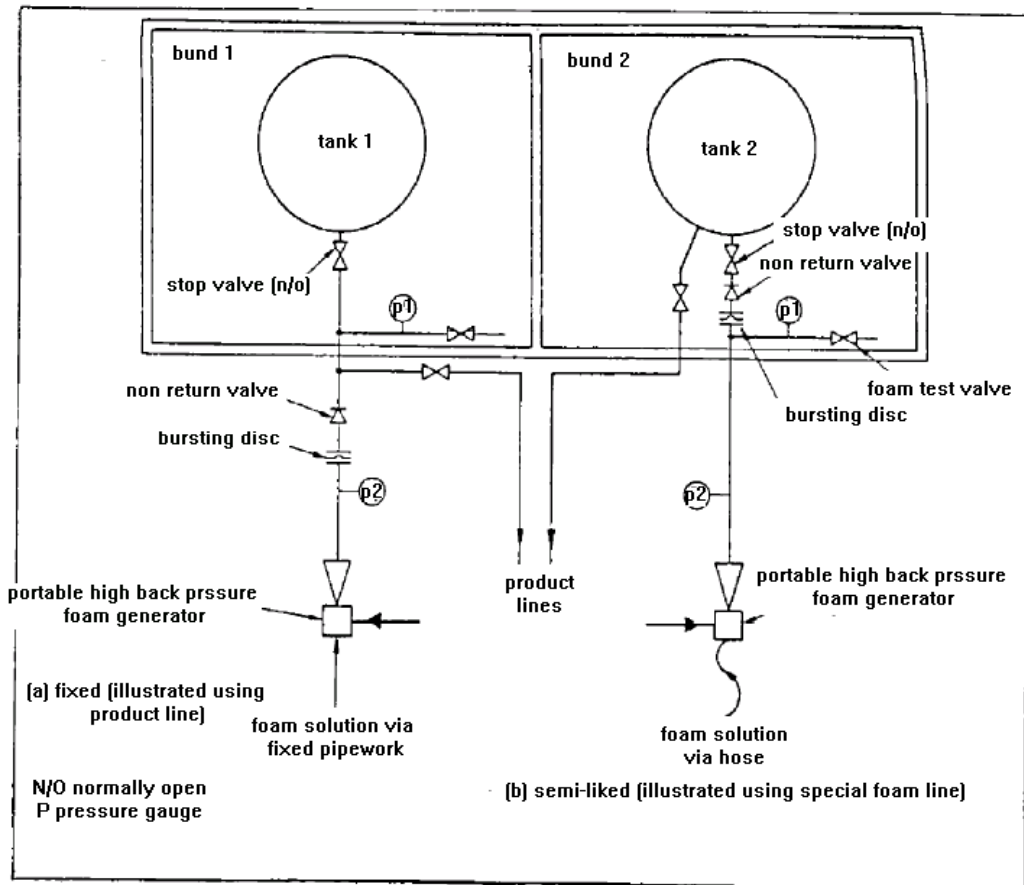

**TYPICAL FIXED AND SEMI-FIXED SUBSURFACE SYSTEMS**

**Fig. 3**

**TABLE 1 - FOAM HANDLINE AND MONITOR PROTECTION FOR FIXED-ROOF STORAGE TANKS CONTAINING HYDROCARBONS**

Hydrocarbon Type	Minimum Application Rate		Minimum Discharge Time (minutes)
	L/min · m <sup>2</sup>	gpm/ft <sup>2</sup>	
Flash point between 37.8°C and 60°C (100°F and 140°F)	6.5	0.16	50
Flash point below 37.8°C (100°F) or liquids heated above their flash points	6.5	0.16	65
Crude petroleum	6.5	0.16	65

**6.11 Semi-Subsurface Systems**

**6.11.1 General**

The requirements of this clause are applicable to systems used to apply foam to the surface of fixed roof storage tanks via a flexible hose rising from the base of the tank. The system is not normally considered appropriate for floating roof tanks with or without a fixed roof, because the floating roof prevents foam distribution. The hose is initially contained in a sealed housing and is connected to an external foam generator capable of working against the maximum product head. On operation the end of the hose is released to float to the liquid surface.

Consideration should be given to the following when considering the selection of this type of system.

- a) The total foam output reaches the surface of the burning liquid.
- b) With large tanks, the semi- subsurface units can be arranged to produce an even distribution over the fuel surface.
- c) Any type of concentrate suitable for gentle surface application to the particular fuel should be used.
- d) Foam generating equipment and operating personnel may be located at a distance from the fire.
- e) The system shall be used for the protection of foam destructive liquids provided the flexible hose is not affected by them.
- f) Certain high viscosity fuels are not suitable for protection by this system.
- g) Circulation of the cold fuel which could assist extinction is not induced.
- h) The system is difficult to check, test and maintain.
- i) The foam generator has to produce foam at a pressure sufficient to overcome the high back pressure of the head of fuel as well as all frictional losses in the foam pipework. Frictional losses with foam differ from those with foam solution.

**6.11.2 Discharge rate**

The discharge rate shall be not less than the appropriate rate given in Table 2 multiplied by the liquid surface area in the tank.

**6.11.3 Duration of discharge**

The minimum duration of discharge shall be as given in Table 1.

**6.11.4 Number and position of units**

The number of units shall be not less than that given in Table 3.

Where more than one unit is required, these shall be spaced equally around the tank shell, away from tank level indicator devices and swing arm product pipes.

**TABLE 2 - MINIMUM APPLICATION RATES FOR POURER SYSTEMS (FIXED ROOF TANKS AND BUNDS) AND SEMI-SUBSURFACE SYSTEMS**

FOAM CONCENTRATE CLASS	FLAMMABLE LIQUID	MINIMUM APPLICATION RATE L/m <sup>2</sup> PER MINUTE
ANY	HYDROCARBON FLASH POINT NOT ABOVE 40°C	4
AR	FOAM DESTRUCTIVE LIQUIDS	6.5

**TABLE 3 - MINIMUM NUMBER OF SUBSURFACE FOAM DISCHARGE OUTLETS FOR FIXED-ROOF TANKS CONTAINING HYDROCARBONS**

Tank Diameter		Minimum Number of Discharge Outlets	
m	ft	Flash Point Below 37.8°C (100°F)	Flash Point 37.8°C (100°F) or Higher
Up to 24	Up to 80	1	1
Over 24 to 36	Over 80 to 120	2	1
Over 36 to 42	Over 120 to 140	3	2
Over 42 to 48	Over 140 to 160	4	2
Over 48 to 54	Over 160 to 180	5	2
Over 54 to 60	Over 180 to 200	6	3
Over 60	Over 200	6	3
		Plus 1 outlet for each additional 465 m <sup>2</sup> (5000 ft <sup>2</sup> )	Plus 1 outlet for each additional 697 m <sup>2</sup> (7500 ft <sup>2</sup> )

**TABLE 4 - MINIMUM DISCHARGE TIMES FOR SEMI-SUBSURFACE AND FIXED FOAM POURER SYSTEMS (EXCEPT OPEN-TOP FLOATING ROOF TANKS) DISCHARGING AT THE MINIMUM RATE**

HAZARD	MINIMUM DISCHARGE TIME MINUTES
SPILLAGE	10 (ALL CLASSES OF FOAM CONCENTRATE)
TANKS CONTAINING LIQUID HYDROCARBONS: FLASH POINT NOT ABOVE 40°C	55 (P) 45 (AFFF, FP AND FFFP)
FLASH POINT ABOVE 40°C	30 (ALL CLASSES OF FOAM CONCENTRATE)
TANKS CONTAINING FOAM DESTRUCTIVE LIQUIDS	55 (AR)
BUNDS	60

For backing-up the sub-surface and semi-sub-surface foam injection systems, mobile/portable foam monitors shall be available with a capacity of 240 m<sup>3</sup>/h water/foam solution, at a working pressure of 10 bar(ga).

## 6.12 Pressure Storage of C<sub>4</sub> and Lighter Hydrocarbons

**6.12.1** Fire protection of pressure storage spheres and vessels containing liquefied hydrocarbons is also based on safe spacing distances. Leakage from large spheres and vessels shall be drained away from underneath the equipment via a sloping floor into a containment channel.

**6.12.2** Spheres and vessels shall be protected against engulfed fires and radiation from the fires of adjacent equipment by automatic water spray systems. The spray system shall ensure an even distribution of water over the entire surface of the sphere or vessel regardless of wind forces or wind direction, but should be divided into separate sections in order to limit water consumption when applying radiation protection.

**6.12.3** The minimum required water rate is 8.5 dm<sup>3</sup>/min/m<sup>2</sup> of equipment surface for engulfed fires. Protection against heat radiation from adjacent equipment will require much less water and shall be calculated on the basis of applicable distances.

## 6.13 LNG and NGL Atmospheric Refrigerated Storage Tanks

**6.13.1** LNG and NGL storage tank fires are unlikely due to the inherent safety of the tank design. If they do occur they cannot be extinguished due to the intensity of the fire and consequently a complete burn-out of the tank has to be accepted. Attempts to extinguish such a fire may produce a cloud of combustible vapor which can be a greater hazard than the tank fire itself. The basic approach to these fires is that of containment and control until ultimate extinction, prevention of escalation and in maintaining the integrity of adjacent equipment particularly if it contains flammable material.

**6.13.2** In order to achieve this purpose, it is necessary to prevent tank roofs and appurtenances, tank walls, pipe bridges and manifolds from exceeding their maximum design temperatures, when an adjacent tank is on fire.

This shall be achieved by:

- Adequate tank spacing
- Tank design.
- Adequate water spray and exposure protection facilities.

Fire protection for LNG and NGL refrigerated storage tanks is highly specialized, therefore systems should be designed by competent technical persons.

## 6.14 Foam Monitors and Handlines

### 6.14.1 Application

This section relates to systems in which foam is applied through fixed or portable monitor or hose streams. They are suitable when used alone for extinguishment of spill fires, diked area fires, and fires in vertical fixed roof atmospheric storage tanks. They are suitable as auxiliary protection in conjunction with fixed systems. Portable hose streams are suitable for extinguishment of rim fires in open-top floating roof tanks.

### 6.14.2 Use of foam handlines and monitors

**6.14.2.1** Monitor nozzles shall not be considered as the primary means of protection for fixed-roof tanks over 18 m in diameter. Foam handlines shall neither be considered as the primary means of protection for fixed-roof tanks over 9 m in diameter nor over 6 m high.

**6.14.2.2** When the entire liquid surface was involved, fires in tanks up to (39 m) in diameter have been extinguished with large capacity foam monitors. Depending on the fixed-roof tank outage and fire intensity, the updraft due to chimney effect shall prevent sufficient foam from reaching the burning liquid surface for formation of a blanket.

**6.14.2.3** Foam should be applied continuously and evenly. Preferably, it should be directed against the inner tank shell so that it flows gently on to the burning liquid surface without undue submergence. This can be difficult to accomplish as adverse winds, depending on velocity and direction, will reduce the effectiveness of the foam stream. Monitors operated at grade usually are not recommended for floating roof rim fire extinguishment because of the difficulty of directing foam into the annular space. Fires in fixed-roof tanks having ruptured roofs with only limited access for foam are not easily extinguished by monitor application from ground level. Fixed foam monitors are installed for protection of drum storage areas or diked areas.

### **6.14.3 Foam application rates**

The minimum delivery rate for primary protection based on the assumption that all the foam reaches the area being protected shall be as called for below. In determining total solution flow requirements, consideration shall be given to potential foam losses from wind and other factors.

#### **6.14.3.1 Tanks containing liquid hydrocarbons**

The foam solution delivery rate shall be at least  $6.5 \text{ L/min/m}^2$  of liquid surface area of the tank to be protected.

#### **Notes:**

1) Included in this section are gasohols and unleaded gasolines containing no more than 10 percent alcohol by volume. When alcohol content exceeds 10 percent by volume, protection is to be in accordance with 6.14.3.2.

2) Flammable liquids having a boiling point of less than  $37.8^\circ\text{C}$  shall require higher rates of application. Suitable rates of application may be determined by test. Flammable liquids with a wide range of boiling points shall develop a heat layer after prolonged burning and then should require application rates of  $[8.1(\text{L/min}/\text{m}^2)]$  or more.

3) Care should be taken in applying portable foam streams to high-viscosity materials heated above  $93.3^\circ\text{C}$ . Judgment should be used in applying foam to tanks containing hot oils, burning asphalts, or burning liquids that are above the boiling point of water. Although the comparatively low water content of foams may beneficially cool such fuels at a slow rate, it shall also cause violent frothing and "slop over" of the contents of the tank.

#### **6.14.3.2 Tanks containing other flammable and combustible liquids requiring special foams**

**6.14.3.2.1** Water soluble and certain flammable and combustible liquids and polar solvents that are destructive to regular foams require the use of alcohol-resistant foams. In general, alcohol-type foams may be effectively applied through foam monitor or foam hose streams to spill fires of these liquids when the liquid depth does not exceed 25 mm. For liquids in greater depths, monitor and foam hose streams shall be limited for use with special alcohol type foams listed for the purpose. In all cases, the manufacturer of the foam concentrate and the foam-making equipment shall be consulted as to limitations and for recommendations based on listings or specific fire tests.

**6.14.3.2.2** The following are minimum application rates:

TYPE OF LIQUID	SOLUTION RATE (L/min)/m <sup>2</sup>
Methyl and ethyl alcohol	6.5
Acrylonitrile	6.5
Ethyl acetate	6.5
Methyl ethyl ketone	6.5
Acetone	9.8
Butyl alcohol	9.8
Isopropyl ether	9.8

**6.14.3.2.3** Products such as isopropyl alcohol, methyl isobutyl ketone, methyl methacrylate monomer, and mixtures of polar solvents in general shall require higher application rates. Protection of products such as amines and anhydrides, which are particularly foam destructive, require special consideration.

**6.14.3.2.4** When using alcohol-resistant foam concentrate, consideration shall be given to solution transit time. Solution transit time (the elapsed time between injection of the foam concentrate into the water and the induction of air) shall be limited, depending on the characteristics of the foam concentrate, the water temperature, and the nature of the hazard protected. The maximum solution transit time of each specific installation shall be within the limits established by the manufacturer

**6.14.3.2.5** If application results in foam submergence, the performance of alcohol-resistant foams usually deteriorates significantly, particularly where there is a substantial depth of fuel. The degree of deterioration of performance will depend on the degree of water solubility of the fuel, i.e., the more soluble, the greater the deterioration.

**6.14.3.3 Durability of discharge**

The equipment shall be capable of operation to provide primary protection at the delivery rates specified in 6-14-3 for the following minimum periods of time:

**a) Tanks Containing Liquid Hydrocarbons:**

Flash point between 37.8°C and 93.3°C.	50 minutes
Flash point below 37.8°C or liquids heated above their flash points	65 minutes
Crude petroleum	65 minutes

**b) Tanks Containing Other Flammable and Combustible Liquids Requiring Special Foams**

Alcohol type foams require special application procedures, as discussed in 6.14.3.2. The operation time shall be 65 minutes at specified application rates, unless the manufacturer has established, by fire test, that a shorter time may be permitted.

**6.14.3.4** Where the system's primary purpose is for spill fire protection, the minimum discharge time shall be 10 minutes for fixed equipment and 15 minutes for portable equipment.

**6.14.4 Protection of hydrocarbon spill fires**

The minimum foam solution delivery rate for the protection of the potential spill area shall be 6.5 L/min/m<sup>2</sup> when protein or fluoroprotein concentrate is used. When AFFF or FFFP concentrate is used, the minimum rate shall be 4.1 L/min/m<sup>2</sup>.

## 6.15 Foam Concentrate and Solution

### 6.15.1 General

**6.15.1.1** Foam concentrate used in the system shall be classified as described in appendix A. The nominal concentration of use shall be not less than that recommended by the manufacturer. The actual concentration, for a fixed system operating at the design application rate, shall be:

- a) For a nominal percentage concentration equal to or greater than 5% within plus or minus one percentage point of the nominal concentration, i.e.  $C \pm 1$ ;
- b) For a nominal percentage concentration less than 5%, but not less than 3%, within plus one percentage point of, and no less than, the nominal concentration, i.e.  $C_{-0}^{+1}$ .
- c) For a nominal percentage concentration less than 3%, within plus one quarter of percentage point of, and no less than, the nominal concentration, i.e.  $C_{-0}^{+25}$ .

**6.15.1.2** Premixed foam solution used in the system shall have a concentration within the range of 0.9 to 1.1 times the value specified by the manufacturer. Only AFFF, FFFP or FP foam concentrate shall be used in subsurface systems.

**6.15.1.3** The nominal concentration which is used for foam concentrates mixtures shall be not less than the higher or highest value recommended by the manufacturer or manufacturers.

**6.15.1.4** Protein (P) foam is not suitable for subsurface systems but shall be used in top application or semi-subsurface systems.

**6.15.1.5** AR foams are formulated for use against fires of foam destructive liquids, but are also suitable for use on hydrocarbon liquids. The fire performance of AR foams against hydrocarbon fuels generally corresponds to the performance of the parent concentrate. The high viscosity of some concentrates needs to be considered when specifying the proportioning system.

The solutions of some AR concentrates are required to be foamed within a specific time of the solution being mixed; it is essential that the solution transit time (the time for foam solution to flow from the point at which concentrate enters the water stream to the point at which air enters the stream, usually expressed in seconds) is less than this limiting time.

When applied forcefully to deep layers of foam destructive liquids, all types of AR foams may show a significant loss of performance compared with results using gentle application. For flammable liquids that are only partially soluble in water, the loss of performance can only be slight but in some cases equipment designed to give very gentle application is necessary. In all cases tests should be conducted or advice sought from the suppliers regarding these liquids.

**6.15.1.6** In portable, transportable and semi-fixed systems the conditions of induction are not controlled by the system design. The actual concentration of use in such systems should be within the above limits when the equipment is used under the conditions specified by the manufacturer.

### 6.16 Foam Quality

**6.16.1** The expansion and drainage time values of foam produced by an aspirating system shall be not less than the values given in Table 5.



**TABLE 5 - MINIMUM VALUES FOR EXPANSION AND 25% DRAINAGE (ASPIRATED FOAM)**

APPLICATION	EXPANSION	25% DRAINAGE TIME min.
SURFACE OR SEMISUBSURFACE	5	2.0 (P, FP) OR 1.5 (AFFF, FFFP)
SUBSURFACE	2 BUT NOT MORE THAN 4	1.5

Values for AR foam shall be not less than the values for the parent class (P, FP, FFFP or AFFF).

The expansion and drainage time of non-aspirated foam is difficult to measure. Values for these are not given in this Standard.

**6.16.2** For detail of test methods, refer to English version of DIN EN 13565-1 "Fixed firefighting systems – Foam systems"

Part 1: Requirements and test methods for components.

**6.17 Dike Area Protection**

Generally portable monitors, or foam hose streams, or both, have been adequate in fighting diked area and other spill fires. In order to obtain maximum flexibility due to the uncertainty of location and the extent of a possible spill in process areas and tank farms, portable or trailer-mounted monitors are more practical than fixed foam systems in covering the area involved.

**6.17.1 Drainage of bunds (Dike)**

Drains and interceptors in banded areas shall be of adequate capacity to carry the anticipated drainage of water used in fire fighting.

**6.18 Water Supplies and Pumps**

**6.18.1 Quantity, pressure and flow rate**

The water supply shall provide the total quantity, flow rate and supply pressure specified for the foam system and for any other fire protection systems which shall be used simultaneously with it, for the specified discharge times.

The supply is reduced by drought or by freezing, or where process water is used to maintain normal working conditions, e.g. for cooling reactors.

Where the primary source is not capable of meeting the system design requirements at all times, storage facilities should be used to meet the shortfall. Consideration should be given to duplication of the water supply pipework, or the use of a ring main system so that the effects of interruptions in the main supply are minimized.

**6.18.2 Quality**

The water supply to foam systems may be hard or soft fresh or salt, but shall be of suitable quality so that adverse effects on foam formation or foam stability does not occur. No corrosion inhibitors, emulsion breaking chemicals, or any other additives shall be present without prior consultation with the foam concentrate supplier.

### 6.18.3 Quantity

The water supply shall be adequate in quantity to supply all the devices that is used simultaneously for the specified time. This includes not only the volume required for the foam apparatus but also water that to be used in other fire fighting operations, in addition to the normal plant requirements. Premixed solution-type systems need not be provided with a continuous water supply.

### 6.18.4 Pressure

The pressure available at the inlet to the foam system (foam generator, air foam maker, etc.) under required flow conditions shall be at least the minimum pressure for which the system has been designed.

### 6.18.5 Temperature

Optimum foam production is obtained using water at temperatures between 4°C and 37.8°C. Higher or lower water temperatures will reduce foam efficiency.

### 6.18.6 Design

The water system shall be designed and installed in accordance with [IPS-E-SF-220](#) "Fire Water Distribution and Storage Facilities".

Where solids of sufficient size to obstruct openings or damage the foam equipment is present, strainers shall be provided. Hydrants furnishing the water supply for foam equipment shall be provided in sufficient number and shall be located as required by the I.P. authorities.

### 6.18.7 Storage

Water supply or premixed solution shall be protected against freezing in climates where freezing temperatures can be expected.

### 6.18.8 Water pumps

When water pumps are required for foam system operation they shall be designed and installed in accordance with [IPS-E-SF-240](#) "Fire Water Pumps".

## 6.19 Storage

**6.19.1** Foam concentrate or premixed solution shall be stored at an accessible location not exposed to the hazard it protects. The material of construction of any building shall be non-combustible. Foam concentrate in shipping containers and in storage tanks should be stored in accordance with the manufacturer's recommendations. Exposure to extreme heat, cold, contamination, or mixing with other materials should be avoided.

Storage containers should be sited where they will be readily accessible for inspection, testing, recharging or maintenance with the minimum of interruption of protection.

During the design stage it should be considered whether it is worthwhile to erect additional foam storage facilities near the tank farm when processing units and tank farm are located at such a distance that a rapid back-up supply of foam concentrate would be hampered.

**6.19.2** Means shall be provided to ensure that the concentrate or premixed solution is kept within its design operating temperature range.

**6.19.3** Storage vessels shall be clearly marked with the class of concentrate and its grade (concentration in the foam solution).

**6.19.4** Storage tanks shall have sufficient ullage to accommodate thermal expansion of the concentrate or solution.

**6.19.5** Only suitable concentrates shall be stored as premixed solutions. Not all foam concentrates are suitable for storage as a premixed solution and the manufacturer's advice should be sought and followed. High storage temperatures may accelerate any deterioration due to aging of the solution.

For smaller hazards a pressure tank is usually used to provide a quick acting automatic system. Nitrogen, Carbon Dioxide or Water is used to expel the contents.

**6.19.6** It is preferable; the capacity of foam barrel shall not exceeded 100 liters.

**6.19.7 Quantities of foam concentrate**

**6.19.7.1** The quantity of foam concentrate or foam solution available for immediate use in the system shall be not less than:

$$V = \frac{A \times R \times C \times T}{100}$$

or

$$V_1 = A \times R \times T$$

**Where:**

- V<sub>1</sub>** is the minimum quantity of foam solution (in L);
- V** is the minimum quantity of foam concentrate (in L);
- A** is the area of application (in m<sup>2</sup>);
- R** is the rate of application of foam solution (in L/m<sup>2</sup> per minute);
- C** is the nominal concentration (in %);
- T** is the duration of application (in min);

Plus sufficient foam concentrate to permit operation of all extra branch pipes simultaneously with the primary means of fire protection and for the minimum discharge duration given in Table 6. Values for the area of application shall not be less than:

- for fixed roof tanks: the area of the bund
- for floating roof tanks: the area of the rim seal
- for spills: the area of the spill
- for bunds: the bund area except for branchpipe and monitor systems when the area of application is half the bund area.

the area of a bond shall be taken as the gross area , less the area of any non- elevated tank or tanks within the bound.

**TABLE 6 - MINIMUM NUMBER OF SUPPLEMENTARY BRANCHPIPES FOR TANKS, AND MINIMUM DISCHARGE TIME**

DIAMETER OF LARGEST TANK (m)	MINIMUM NUMBER OF FOAM BRANCHPIPES	MINIMUM DISCHARGE TIME (min)
UP TO 10	1	10
OVER 10 UP TO 20	1	20
OVER 20 UP TO 30	2	20
OVER 30 UP TO 40	2	30
OVER 40	3	30

**6.19.7.2 System discharge rate**

The discharge rates of portable branchpipe and monitor systems shall be not less than the appropriate minimum application rate given in Table 7 multiplied by the area of the tank or spill, or by half the area of the bund, as appropriate, when tested in accordance with Appendix D.

Higher minimum rates may be needed if there is exceptional loss of foam because of wind or fire updraught.

Minimum rates for liquids with flash point not above 40°C, and for other liquids not listed in the table should be determined by specific test, or from the concentrate manufacturer’s data.

For bund protection systems, in addition to the above requirement the system discharge rate and the actual area of application is not less than that given in Table 7.

**TABLE 7 - MINIMUM APPLICATION RATES FOR MONITOR AND BRANCHPIPE SYSTEMS**

FOAM CONCENTRATE RATE CLASS	MINIMUM APPLICATION RATES OF FOAM SOLUTION L/m <sup>2</sup> /min.			HAZARD
	SPILL FIRES	TANK FIRES	BUND FIRES*	
AFFF FFFP FP	4 4 5	6.5 6.5 6.5	4 4 5	HYDROCARBON, FLASH POINT ABOVE 40°C
P	6.5	8	6.5	HYDROCARBON, FLASH POINT ABOVE 40°C
AR	BY TEST	NOT SUITABLE	BY TEST	FOAM DESTRUCTIVE LIQUIDS, FLASH POINT ABOVE 40°C

(\* See Clause 6.14) Suitable when used alone for extinguishment of spill fires.

**6.19.7.3** The hazard requiring the greatest quantity of foam concentrate shall be used to determine the amount to be held at immediate readiness.

**6.19.7.4** Allowance shall be made for the quantity of foam concentrate needed to fill the feed lines installed between the source and the most remote monitor or branchpipe.

**6.19.7.5** A reserve supply of foam concentrate shall be available to enable the system or systems to be put back into service within 24h of operation. This supply maybe stored in separate tanks, in drums or cans on the premises or be available from an outside source.

Adequate loading and transportation facilities should be assured at all times.

Other equipment which are necessary to re-commission the system, such as bottles of nitrogen or carbon dioxide for premix systems, should also be readily available.

**6.20 Foam Concentrate Pumps**

Pumps for foam concentrate shall be self-priming or flooded-suction pumps, driven by a suitable prime mover which is constantly available.

Pumps shall have adequate capacity to meet the maximum system requirements. To ensure positive injection, the discharge pressure rating at design discharge capacity shall be sufficiently in excess of the maximum water pressure under any condition at the point of injection of the concentrate.

**6.21 Hydrants**

In addition to a primary fixed piping system and any supplementary protection foam hydrants shall be provided for use with portable or mobile equipment or water hydrants with suitable foam producing equipment in the event that a fixed discharge outlet on the primary protection system is damaged.

The number of hydrants, which may have more than one outlet, shall be as shown in Table. 8.

**TABLE 8 - MINIMUM NUMBER OF HYDRANTS FOR SUPPLEMENTARY PROTECTION OF STORAGE TANKS**

TANK DIAMETER (m)	MINIMUM NUMBER OF HYDRANTS
UP TO 20	1
OVER 20	2

Each hydrant should be located between 15 m and 75 m from the shells of the tanks being protected by the associated primary system.

The flow from hydrants should be sufficient for all the portable equipment to be used.

**6.22 Foam Concentrate Facilities**

The vessel(s) for foam concentrate storage shall be installed at a safe and readily accessible location, preferably near the fire station. The vessel(s) shall be equipped with a pressure-vacuum valve set at both approximately 5 mbar vacuum and pressure, installed on the manhole cover. On the same cover a 1½-in. inlet shall be provided fitted with a threaded cap with dipstick to measure the liquid level of the foam concentrate, see Appendix D.

Via this inlet a sealing liquid shall be supplied in order to avoid oxidation of the foam. For this purpose the foam level shall also be maintained just under the manhole cover.

The elevation of the 2½-in. outlet hose connection shall be approximately 3 m above ground level to enable filling of mobile equipment by gravity.

An electric motor-driven pump shall be installed to fill the vessel from drums. The pump capacity shall be approximately 3 dm<sup>3</sup>/s at a discharge pressure of 3 bar gauge. An unloading rack with a foam collector underneath shall be installed.

The pump should also be connected to the vessel for circulating the foam to avoid sediment formation.

**6.23 Automatically Operated Systems**

Automatic systems shall incorporate a manually operated lock-off device which will prevent discharge of the system, but will not prevent the giving of the alarm signal.

Operation of the lock-off device shall be indicated at the plant or fire control center.

The lock-off device is for use when maintenance personnel are working on the system.

**6.24 Detection and Alarm Equipment**

Automatic detection and control equipment shall give a positive warning of any fault or abnormality, e.g. loss of power or pressure which may render the detection and control system inoperative.

Automatic detection equipment shall provide a local alarm at the control point of each automatic system, as well as at the plant or central control point.

Automatic systems should include a facility for coincidental shutdown of any heat source or potential means of ignition or reignition in the vicinity of the hazard. Detection and alarm equipment may be electrical, pneumatic, hydraulic or mechanical, e.g. link line type.

Automatic detection and control equipment should comply with [IPS-E-SF-260](#) automatic gas detection and alarm systems.

## 7. FOAM SPRAY SYSTEMS

### 7.1 General

**7.1.1** The requirements of this clause are applicable to systems discharging a spray of aspirated foam or non-aspirated foam solution to provide primary protection for flammable liquid spills.

The spray nozzles shall be arranged to discharge downwards in overhead systems, horizontally or upwards as in ground level pop-up sprayers.

Spray systems are particularly suitable both outdoors and indoors where flammable liquids may be spilled in large quantities. Typical examples include loading racks, horizontal tanks, pump rooms, dip tanks and bunds.

Generally these systems are not suitable for use on water miscible liquids exceeding 25 mm in depth.

Any type of foam concentrate shall be used in aspirating systems, but for non-aspirating systems only AFFF or FFFP has to be used. Nonaspirating systems should be regarded as water spray systems discharging foam solution.

**7.1.2** Consideration should be given to the following when selecting one of the many variations of this type of system.

- a) Hot surfaces in contact with the fuel can be effectively cooled by a spray discharge. Structures should also be protected from heat radiation by a spray discharge.
- b) The system is particularly suitable for automatic operation. Automatic operation is for indoor or unmanned hazards.
- c) Even distribution of the foam over the fuel surface is achieved but discharge is carried by the wind beyond the area of the fuel spill except where ground level pop-up nozzles, which deliver foam at the seat of the fire, are used.
- d) Foam sprayers have small passages susceptible to blockage.
- e) Obstructions, such as vehicles or equipment temporarily positioned, may be present when the system is operated and may interfere with the discharge.
- f) Pipework for overhead nozzles obstructs normal activities, or impose an undue load on the roof structure.
- g) Overhead application needs supplementary low level application to provide coverage below large obstructions, such as aircraft in hangars.
- h) For hazards where a large spill area is likely to be involved, the foam spray system shall be subdivided into zones, each protecting specific floor area and individually actuated by a suitable fire detection system.
- i) Non-aspirated nozzles can be used to apply a spray of water, instead of foam solution, which can provide effective fire control of some flammable liquids.

#### Notes:

**1) Spray foam applied externally to tanks or vessels has the added advantages of cooling and insulating the tanks or vessels while the spill fire is being extinguished. Overhead pipework for overhead applicators must neither obstruct normal operations nor impose an undue load on the roof structure. While foam is not considered an effective agent for extinguishing Three-dimensional running flammable liquid fires, it can control the pool fire underneath the running fire, thus permitting control by other means.**

**2) These systems should also be used to protect small outdoor open-top tanks having a liquid surface area not exceeding 18.6 m<sup>2</sup>.**

**7.2 Discharge Rate**

Systems shall deliver foam solution at not less than the appropriate minimum application rate given in table 9. multiplied by the area of the spill.

Application rates for foam destructive liquids should be determined by specific test or taken from the foam concentrate manufacturer’s data.

**7.3 Duration of Discharge**

The minimum duration of discharge of systems discharging at the minimum rate specified in 7.2 shall be as given in Table 10. The minimum duration of discharge of systems discharging at higher than the minimum rate may be reduced in proportion but shall be not less than 70% of the time given in Table 10. The minimum duration of discharge for foam destructive liquids should be determined by specific test or taken from the foam concentrate manufacturer’s data.

**7.4 Number and Location of Discharge Outlets**

There shall be not less than one discharge outlet per 10 m<sup>2</sup> of protected area.

Generally, sprayers should be spaced to provide even distribution over the whole area. For some hazards it may be advantageous to cluster sprayers in areas where fire is likely to originate.

**TABLE 9 - MINIMUM APPLICATION RATES FOR SPRAYER SYSTEMS (HYDROCARBON LIQUIDS ONLY)**

FOAM CONCENTRATE CLASS	HEIGHT OF DISCHARGE POINT ABOVE LOWEST POINT OF HAZARD	MINIMUM APPLICATION RATE	
		ASPIRATED L/m <sup>2</sup> /min.	NON-ASPIRATED L/m <sup>2</sup> /min.
P	UP TO AND INCLUDING 10 ABOVE 10	6.5 8	NOT SUITABLE
FFFP AFFF	UP TO AND INCLUDING 10 ABOVE 10	6.5 8	4 6.5
FP	UP TO AND INCLUDING 10 ABOVE 10	6.5 8	NOT SUITABLE

**TABLE 10 - MINIMUM DISCHARGE TIMES FOR SPRAYER SYSTEMS (HYDROCARBON LIQUIDS ONLY) DISCHARGING AT THE MINIMUM RATE**

HAZARD	AREA OF SYSTEM OR ZONE (m <sup>2</sup> )	MINIMUM DISCHARGE TIME FOR ALL CLASSES OF FOAM CONCENTRATE (min)
INDOOR CONTAINED LIQUID HYDROCARBON SPILLS	50 OR LESS	5
	MORE THAN 50	10
INDOOR OPEN TOP PROCESS TANKS CONTAINING LIQUID HYDROCARBONS	50 OR LESS	5
	MORE THAN 50	10
OUTDOOR APPLICATIONS	ANY AREA	10

**8. MEDIUM AND HIGH-EXPANSION FOAM SYSTEMS**

**8.1 General**

**8.1.1** High expansion foam is an agent for control and extinguishment of Class A and Class B fires and is particularly suited as a flooding agent for use in confined spaces. The development of the use of high expansion foams for fire fighting purposes started with the work of the Safety in Mines Research Establishment of Buxton, England, upon the difficult problem of fires in coal mines. It was

found that by expanding an aqueous surface active agent solution to a semi-stable foam of about 1,000 times the volume of the original solution, it was possible to force the foam down relatively long corridors, thus providing a means for transporting water to a fire inaccessible to ordinary hose streams.

This work has led to the development of specialized high expansion foam-generating equipment for fighting fires in mines, for application in municipal industrial fire fighting, and for the protection of special hazard occupancies. Medium expansion foam was developed to cover the need for a foam more wind resistant than high expansion foam for outdoor applications.

**8.1.2** Medium and high expansion foams are aggregations of bubbles mechanically generated by the passage of air or other gases through net, screen, or other porous medium that is wetted by an aqueous solution of surface active foaming agents. Under proper conditions, fire fighting foams of expansions from 20:1 to 1000:1 can be generated. Such foams provide a unique agent for transporting water to inaccessible places; for total flooding of confined spaces; and for volumetric displacement of vapor, heat, and smoke. Tests have shown that, under certain circumstances, high expansion foam, when used in conjunction with water sprinklers, will provide more positive control and extinguishment than either extinguishment system by itself. High-piled storage of rolled paper stock is an example. Optimum efficiency in any one type of hazard is dependent to some extent on the rate of application and also the foam expansion and stability.

Medium and high expansion foams, which are generally made from the same type of concentrate, differ mainly in their expansion characteristics.

**8.1.3** Medium expansion foam is used on solid fuel and liquid fuel fires where some degree of in-depth coverage is necessary, e.g., for the total flooding of small enclosed or partially enclosed volumes such as engine test cells, transformer rooms, etc. It can provide quick and effective coverage of flammable liquid spill fires or some toxic liquid spills where rapid vapor suppression is essential. It is effective both indoors and outdoors.

**8.1.4** High expansion foam shall also be used on solid and liquid fuel fires but the in-depth coverage it can give is greater than for medium expansion foam. It is therefore most suitable for filling volumes in which fires exist at various levels. For example, experiments have shown that high expansion foam can be used effectively against high rack storage fires provided that the foam application is started early and the depth of foam is rapidly increased. It can also be used for the extinction of fires in enclosures where it is dangerous to send personnel, e.g., in basement and underground passages. It can be used to control fires involving liquefied natural gases and LPG and to provide vapor dispersion control for LNG and ammonia spills.

High expansion foam is particularly suited for indoor fires in confined spaces. Its use outdoors may be limited because of the effects of wind and lack of confinement.

**8.1.5** Medium and high expansion foam have several effects on fires:

- a)** When generated in sufficient volume, they can prevent free movement of air, necessary for continued combustion.
- b)** When forced into the heat of a fire, the water in the foam is converted to steam, reducing the oxygen concentration by dilution of the air.
- c)** The conversion of the water to steam absorbs heat from the burning fuel. Any hot object exposed to the foam will continue the process of breaking the foam, converting the water to steam, and of being cooled.
- d)** Because of their relatively low surface tension, solution from the foams that is not converted to steam will tend to penetrate Class A materials. However, deep seated fires shall require overhaul.
- e)** When accumulated in depth, medium and high expansion foam can provide an insulating barrier for protection of exposed materials or structures not involved in a fire and can thus prevent fire spread.
- f)** For liquefied natural gas (LNG) fires, high expansion foam will not normally extinguish a fire but it reduces the fire intensity by blocking radiation feedback to the fuel.
- g)** Class A fires are controlled when the foam completely covers the fire and burning



material. If the foam is sufficiently wet and is maintained long enough, the fire can be extinguished.

**h)** Class B fires involving high flash point liquids can be extinguished when the surface is cooled below the flash point. Class B fires involving low flash point liquids can be extinguished when a foam blanket of sufficient depth is established over the liquid surface.

## 8.2 Mechanisms of Extinguishment

Medium and high expansion foam extinguishes fire by reducing the concentration of oxygen at the seat of the fire, by cooling, by halting convection and radiation, by excluding additional air, and by retarding flammable vapor release.

## 8.3 Use and Limitations

While medium and high expansion foams are finding applications for a broad range of fire fighting problems, each type of hazard shall be specifically evaluated to verify the applicability of medium or high expansion foam as a fire control agent.

**8.3.1** Some important types of hazards that medium and high expansion foam systems may satisfactorily protect include:

- a)** Ordinary combustibles
- b)** Flammable and combustible liquids
- c)** Combinations of (a) and (b)
- d)** Liquefied natural gas (high expansion foam only).

**8.3.2** Ability to control or extinguish a fire in a given hazard may depend on such factors as expansion, drainage, and fluidity. These factors will vary with the concentrate, equipment, water supply, and air supply.

**8.3.3** Susceptibility of the protected hazard to water damage shall be evaluated.

**8.3.4** Medium and high expansion foam systems shall not be used on fires in the following hazards unless competent evaluation, including tests, indicates acceptability:

- a)** Chemicals, such as cellulose nitrate, that release sufficient oxygen or other oxidizing agents to sustain combustion.
- b)** Energized unenclosed electrical Equipment.
- c)** Water-reactive metals such as sodium, (Na), potassium, (K).
- d)** Hazardous water-reactive materials, such as triethylaluminum and phosphorous pentoxide.
- e)** Liquefied flammable gas.

## 8.4 Expansion

Foams are arbitrarily subdivided into three ranges of expansion.

Low expansion foam (LX): expansion up to 20

Medium expansion foam (MX): expansion 21 to 200

High expansion foam (HX): expansion 201 to 1000

## 8.5 Application Method

### 8.5.1 Medium expansion

Medium expansion foams shall be applied:

- a) Gently to the surface of a flammable liquid or solid combustible fire; or
- b) By means of a medium expansion foam branchpipe or monitor.

The first method is suitable for fixed systems where the location, size and shape of the hazard is known, and the system can be designed to meet this requirement. The second method is more appropriate where the size and location of the hazard vary with circumstance, and needs to be dealt with by a more flexible approach.

### 8.5.2 High expansion

High expansion foams shall be applied:

- a) By filling the volume in which the fire occurs; or
- b) By guiding a wall of foam in the direction of a localized fire, in order to submerge and suppress it.

The foam may be introduced directly, or through flexible ducting. High expansion foam, by its nature, can only be applied gently to fires. Method (a) is generally preferable as the water content of the foam needs to be retained as far as possible to ensure heat resistance at the fire. Horizontal movement at floor level promotes water drainage and degrades the foam quality. To make high expansion foam effective in large compartments and up to heights of 10 m, flexible barriers shall be used to retain the foam in the required area and to permit its fast build up to the required height. Wherever possible foam should be applied at a high level, i.e. above the level of foam in the fire space.

## 8.6 System Design

### 8.6.1 General

The system shall be designed to suit the particular hazard, and the following shall be considered when preparing the design:

- a) Full details of the solid combustibles and/or flammable liquids, their methods of storage and packaging, handling and location.
- b) The most suitable class of foam concentrate, concentration and solution application rate.
- c) The most suitable method of application of the foam, and the most suitable equipment to provide this method, including the method of proportioning.
- d) The quantity of foam concentrate required for extinction, including back-up supplies where extended application is necessary for concealed or prolonged fires.
- e) The required system operation time taking into account item(d).
- f) The quantity of foam concentrate to be held in reserve.
- g) Water supply quantity, quality and pressure.
- h) Pipework sizes and pressure losses.
- i) Method of system operation, and any fire or gas detection equipment required; need for a manual override where personnel are present.
- j) Any special considerations, e.g. the need to use flameproof electrical equipment where flammable vapors are present.

- k) Drainage and bunds.
- l) Environmental conditions.

### 8.6.2 Compatibility with other extinguishing media

The foam produced by the system shall be compatible with any media provided for application at or about the same time as foam. Certain wetting agents and some extinguishing powders are incompatible with foams, causing rapid breakdown of the latter. Only media that are substantially compatible with a particular foam should be used in conjunction with it.

Water jets or sprays shall adversely affect a foam blanket, but the simultaneous application of water from sprinklers can be beneficial provided that allowance is made for the increased breakdown of foam.

### 8.6.3 Compatibility of foam concentrates

Foam concentrate (or solution) added or put into a system shall be suitable for use and compatible with any concentrate (or solution) already present in the system. Foam concentrates, and foam solutions, even of the same class, are not necessarily compatible, and it is essential that compatibility be checked before mixing two concentrates or premixed solutions.

### 8.6.4 Foam destructiveness

For the purposes of this standard when considering foam destructiveness, flammable liquids are considered as falling into two groups:

- a) Hydrocarbons, and those non-hydrocarbon liquids which are not more foam destructive than hydrocarbons;
- b) Foam destructive liquids, which are generally water soluble and which are much more foam destructive than hydrocarbons.

Special types of concentrate are used for foam destructive liquids. Higher rates of application are specified for foam destructive liquids than for hydrocarbons and it is usually essential to use gentle application methods.

The degree of foam destructiveness varies however, and isopropyl alcohol, butyl alcohol and isobutyl methyl ketone, methyl methacrylate monomer and mixtures of water-miscible liquids in general shall require higher application rates. Protection of products such as amines and anhydrides which are particularly foam destructive require special consideration.

## 8.7 Water, Foam Concentrate, and Air Supply

### 8.7.1 Water quantity

Water shall be available in sufficient quantity and pressure to supply the maximum number of medium and high expansion foam generators likely to operate simultaneously in addition to the demands of other fire protection equipment.

### 8.7.2 Water pumps

**8.7.2.1** The pump shall supply water to the inlet of the foam system within the range of flow and pressure for which the system is designed. Pumps providing a water supply to foam equipment should be correctly sized, so that at maximum demand they operate below their overload characteristic.

They should be capable of operating satisfactorily following long periods of inactivity.

Where an alternative water supply is available a single pump shall be used, otherwise multiple

pump arrangements are preferred to improve reliability.

**8.7.2.2** Diesel engines are preferred to electric motors for driving pumps. The use of one diesel driven and one electrically driven pump of appropriate size is an acceptable arrangement.

**8.7.2.3** The electric power supply to a pump should be a separately switched circuit, where only electric pumps are used an alternative independent supply of electric power should be provided.

### **8.7.3 Water storage**

Water supply shall be protected against freezing.

### **8.7.4 Foam concentrate quantity**

The amount of foam concentrate in the system shall be at least sufficient for the largest single hazard protected or a group of hazards that are to be protected simultaneously.

### **8.7.5 Air supply**

Air from outside the hazard area shall be used for foam generation unless data is provided to show that air from inside the hazard can be successfully employed. The data shall be specific for the products of combustion to be encountered and shall provide factors for increasing foam discharge rates over those given in Clause 8.8.4.4.

**8.7.5.1** Vents shall be located to avoid recirculation of combustion products into the air inlets of the foam generators.

### **8.7.6 Foam-generating apparatus location**

#### **8.7.6.1 Accessibility for inspection and maintenance**

Foam-generating apparatus shall be so located and arranged that inspection, testing, recharging, and other maintenance is facilitated and interruption of protection is held to a minimum.

#### **8.7.6.2 Protection against exposure**

Foam-generating equipment shall be located as close as possible to the hazard(s) it protects, but not where it will be unduly exposed to a fire or explosion. Foam generators installed inside the hazard area shall be constructed to resist or protected against fire exposure.

Such protection may be in the form of insulation, fire-retardant paint, water spray, or sprinklers, etc. In certain applications additional generators shall be substituted for fire exposure protection with the approval of the authorities concerned.

### **8.7.7 Ducts**

Foam distribution and air inlet ducts shall be designed, located, installed, and suitably protected so that they are not subject to undue mechanical, chemical or other damage.

**8.7.7.1** Duct closures such as selector valves, gates, or doors shall be of the quick-opening type, allowing free passage of the foam. When located where they may be subjected to fire or heat exposure, either inside or outside the area to be protected, special care shall be taken to ensure positive operation.

**8.7.7.2** Ducts shall be designed and installed so that undue turbulence is avoided and the actual foam discharge rate shall be determined by test or other method acceptable to the relevant authorities.

**8.8 Foam Requirements for Medium Expansion Foam Systems**

**8.8.1 Application rate**

**a) Flammable liquids**

The application rate, determined in accordance with Appendix B, shall be not less than:

- The rate, agreed with the user, shown to be effective by tests; or
- If test data is not available:

4L/m<sup>2</sup>.min for hydrocarbon liquids, or 6.5L/m<sup>2</sup> per minute for foam destructive liquids.

**b) Combustible solids**

The application rate, determined in accordance with Appendix B, shall be not less than the rate agreed with the user.

**8.8.2 Duration of discharge**

The minimum duration of discharge of systems discharging at the minimum rate specified in 7-8-1 shall be as given in table (1). The minimum duration of systems discharging at higher than the minimum rate may be reduced in proportion but shall be not less than 70% of the time given in Table (11).

**TABLE 11 - MINIMUM DISCHARGE TIMES FOR MEDIUM EXPANSION FOAM SYSTEMS DISCHARGING AT THE MINIMUM RATE**

HAZARD	MINIMUM DISCHARGE TIME (min)
INDOOR AND OUTDOOR SPILL UP TO 100 m <sup>2</sup>	10
OTHER INDOOR HAZARDS AND OUTDOOR PROTECTION	15

**8.8.3 Quantity of foam concentrate**

a) The quantity of foam concentrate or premix available for immediate use in the system shall be as given in Clause 6.19.6.

**8.8.4 Foam requirements for high expansion foam systems**

**8.8.4.1 Vent design**

The vent(s) shall be positioned at the most remote point(s) from the foam inlets(s), and shall be to the open air. The vent(s) shall be of open design, or if normally closed shall open automatically on actuation of the system.

Correct positioning of the vent(s) is necessary to ensure that the submergence depth is achieved throughout the protected area. Venting is to the outside air to allow the safe dispersal of smoke and combustion products.

The area of the vent(s) should be sufficient to limit the venting velocity to not more than 300 m/min.

This will be achieved if the vent area (in m<sup>2</sup>) is not less than F/300, where F is the foam discharge rate in m<sup>3</sup>/min.

Venting is not usually necessary where air from within the enclosure is used to make the foam.

**8.8.4.2 Submergence depth**

The system shall produce, throughout the protected area, a depth of foam sufficient to cover and extinguish the highest hazard.

In unsprinklered enclosures of combustible construction the submergence depth should be sufficient to fill the enclosure.

For combustible solids, in enclosures which are sprinklered or are of non-combustible construction the submergence depth should be sufficient to cover the highest hazard with 1 m, or 0.1 times the height of the highest hazard, in meters, whichever is the greater, of foam.

For flammable liquids the submergence depth should be determined by test, and shall be considerably more than for combustible solids.

**8.8.4.3 Submergence time**

The system shall produce throughout the protected area a depth of foam not less than the submergence depth in not more than the appropriate maximum time given in Table 12.

**TABLE 12 - MAXIMUM SUBMERGENCE TIMES FOR HIGH EXPANSION FOAM SYSTEMS**

HAZARDS	MAXIMUM SUBMERGENCE TIMES	
	HIGH EXPANSION FOAM ONLY (min)	HIGH EXPANSION FOAM WITH SUPPORTING WATER SPRINKLERS (min)
FLAMMABLE LIQUIDS WITH FLASH POINTS NOT ABOVE 40°C	2	3
FLAMMABLE LIQUIDS WITH FLASH POINTS ABOVE 40°C	3	4
LOW DENSITY COMBUSTIBLE SOLIDS, e.g. FOAM RUBBER, FOAM PLASTICS, ROLLED TISSUE OR CREPE PAPER	3	4
HIGH DENSITY COMBUSTIBLE SOLIDS, e.g. ROLLED PAPER, RUBBER TYPES	5	7

**8.8.4.4** In calculating the foam application rate, the volume of vessels, machinery or other permanently located equipment may be deducted from the total volume to be protected. Volumes occupied by stored materials are not deducted from the volume of the area to be protected, since the quantity may vary with time.

Provided appropriate attention is given to distribution the requirements for submergence time will be met if the discharge rate of the system is not less than:

$$F = C_N \times C_L \times \frac{[F_s + (D \times A) - V_{eq}]}{T}$$

**Where:**

- D** is the submergence depth (in m);
- F** is the foam discharge rate (in m<sup>3</sup>/min);
- T** is the submergence time (in min);
- A** is the floor area of the protected space (in m<sup>2</sup>)

$V_{eq}$  is the volume of any permanently installed equipment, vessels or machinery, excluding the volume of any removable stored materials or equipment (in  $m^3$ ).

$C_N= 1.20$ , an empirical factor based on the average reduction in foam quantity due to solution drainage, fire, wetting of dry surfaces, etc.

$C_L= 1.1$  an empirical factor compensating for the loss of foam due to leakage around doors and windows where these are closed but not sealed.

$F_s$  is the rate of foam breakdown by sprinkler discharge (in  $m^3/min$ ). This factor should be determined either by test or, in the absence of specific test data by the following formula:

$$F_s = 0.075 \times Q$$

**Where:**

$Q$  is the estimated total discharge from the maximum number of sprinklers expected to operate (in L/min).

**8.8.4.5 Quantity of foam concentrate**

The quantity of foam concentrate (in liters) available for immediate use in the system shall be not less than:

a) For fire involving combustible solids:

$$250 \times \frac{FC}{E}$$

b) For fires involving flammable liquids:

$$150 \times \frac{FC}{E}$$

**Where:**

$F$  is the foam discharge rate (in  $m^3/min$ )

$C$  is the concentration (in%);

$E$  is the expansion.

The quantities specified allow system running times (whether continuously or intermittently) to 25 min for combustible solids and 15 min for flammable liquids. For flammable liquids it is usual for the system to run continuously but for systems protecting combustible solids once submergence is achieved it is usual to run the system intermittently, in effect discharging foam at a rate equivalent to the breakdown rate, to maintain the submergence depth for the maximum time possible.

**8.8.4.6 Types of systems**

The types of systems recognized in this standard include:

Total Flooding Systems

Local Application Systems

Portable Foam Generating Devices

## 8.9 Total Flooding Systems

### 8.9.1 General information

#### 8.9.1.1 Description

A total flooding system consists of fixed foam-generating apparatus complete with a piped supply of foam concentrate and water, arranged to discharge into an enclosed space or enclosure around the hazard.

#### 8.9.2 Uses

This type of system shall be used where there is a permanent enclosure around the hazard that is adequate to enable the required amount of fire extinguishing medium to be built up and to be maintained for the required period of time to ensure the control or extinguishment of the fire in the specific combustible material(s) involved.

**8.9.2.1** Examples of hazards that are successfully protected by total flooding systems include rooms, vaults, storage areas, warehousing facilities and buildings containing Class A and Class B combustibles either singly or in combination.

**8.9.2.2** Fires that can be controlled or extinguished by total flooding methods are divided into three categories:

- a) Surface fires involving flammable or combustible liquids and solids,
- b) Deep-seated fires involving solids subject to smoldering'
- c) Three-dimensioned fires in some flammable liquids.

#### 8.9.3 General requirements

Total flooding systems shall be designed, installed, tested, and maintained in accordance with the applicable requirements in clause 6.12 of NFPA 11 and with the additional requirements set forth in this section. Only listed or approved equipment and devices shall be used in these systems.

#### 8.9.4 Enclosure specifications

##### 8.9.4.1 Leakage and ventilation

Since the efficiency of the medium or high expansion foam system depends on the development and maintenance of a suitable quantity of foam within the particular enclosure to be protected, leakage of foam from the enclosure shall be avoided.

**8.9.4.2** Openings below design filling depth, such as doorways, windows, etc., shall be arranged to close automatically before, or simultaneously with, the start of the foam discharge, with due consideration for evacuation of personnel. They shall be designed to maintain a closure during a fire and be capable of withstanding pressures of foam and sprinkler water discharge. If any unclosable openings exist, the system shall be designed to compensate for the probable loss of foam and shall be tested to assure proper performance.

The venting so required shall consist of suitable openings, either normally open, or normally closed and arranged to open automatically when the system operates. When design criteria demand exhaust fans, they shall be approved for high-temperature operation and installed with due consideration for protection of switches, wiring, and other electrical devices to ensure equal reliability of exhaust fan performance as for the foam generators. Where forced air ventilating systems interfere with the proper build up of foam, they shall be shut down or closed off automatically.



#### **8.9.4.4 Rate of discharge**

See Clause 8.8.4.4.

#### **8.9.4.5 Quantity**

Sufficient high expansion foam concentrate and water shall be provided to permit continuous operation of the entire system for 25 minutes or to generate four times the submergence volume, whichever is less, but in no case less than enough for 15 minutes of full operation. The quantity for medium expansion foam shall be determined by suitable tests developed by an independent testing laboratory.

### **8.10 Local Application Systems**

#### **8.10.1 General information**

##### **8.10.1.1 Description**

A local application system consists of fixed foam-generating apparatus complete with a piped supply of foam concentrate and water and arranged to discharge foam directly onto the fire of spill.

##### **8.10.1.2 Uses**

Local application systems are used for the extinguishment or control of fires in flammable or combustible liquids, liquefied natural gas (LNG), and ordinary Class A combustibles where the hazard is not totally enclosed. These systems are best adapted to the protection of essentially flat surfaces such as confined spills, open tanks, drainboards, curbed areas, pits, trenches, etc. For multiple-level or three-dimensional fire hazards where total building flooding is not practical, the individual hazard shall be provided with suitable containment facilities acceptable to the I.P. authorities.

##### **8.10.1.3 General requirements**

Local application systems shall be designed, installed, tested, and maintained in accordance with the applicable requirements in total flooding and with the additional requirements set forth in this section. Only listed or approved equipment, devices, and agents shall be used in these systems.

#### **8.10.2 Hazard specifications**

##### **8.10.2.1 Location of hazard**

Local application medium and high expansion foam systems shall be used to protect hazards located indoors, partly sheltered, or completely out-of-doors. Provisions shall be made to compensate for winds and other effects of weather.

#### **8.10.3 Foam requirements for flammable and combustible liquids and solids**

**8.10.3.1** Sufficient foam shall be discharged at a rate to cover the hazard to a depth of at least (0.6 m) within 2 minutes (see 7.2) and (8.8.4.4).

### 8.10.3.2 Quantity

Sufficient foam concentrate and water shall be provided to permit continuous operation of the entire system for at least 12 minutes. (See 8.8.4.5)

- a) Reserve supplies shall be provided in accordance with 6.19.6.5.

## 8.10.4 Foam applications for liquefied natural gas (LNG)

### 8.10.4.1 General

High expansion foam has been shown to be effective in controlling LNG spill test fires and in reducing down wind vapor concentration from unignited LNG spill test fires in confined areas up to (111 m<sup>2</sup>).

### 8.10.4.2 System design considerations

The determination of the high expansion foam system design depends on an analysis specific to the individual site. Since time to initiate actuation is a critical factor in LNG fire control, the analysis must consider effects of heat exposure on adjacent plant equipment. In many cases automatic alarms and actuation will be required for fixed systems.

### 8.10.4.3 Application rate

As established by test, the application rate shall be such that a positive and progressive reduction in radiation is attained within the time limitations established in the analysis. The application rates determined by the test shall be increased by the necessary factor to account for the initial vaporization rate and the configuration of the hazard. After steady state control conditions have been reached, the application rates for maintenance of fire control established in the test shall be used to maintain control.

### 8.10.4.4 Quantity

The initial quantity of foam concentrate shall permit a continuous application at the initial design rate sufficient for fire control to reach steady state conditions. Additional foam concentrate supplies shall be on hand to provide control maintenance for the calculated fire duration.

### 8.10.4.5 Foam system arrangement

The foam system shall have foam outlets so arranged to supply foam to cover the design fire area within the specified time.

## 8.11 Portable Foam-Generating Devices

This section is covered in Material Standard under reference No. [IPS-M-SF-144](#).

## 8.12 Safety Hazards

### 8.12.1 Personnel safety

Foam solutions are generally not considered toxic to humans but contact shall cause skin or eye irritation. Read warning labels on foam concentrate containers. Effects and antidotal procedures will vary for each foam agent.

**8.12.2** Fragments generated by the rupture of dry foam layers can cause sneezing and coughing.

These effects are transient and will stop when exposure to the source of the fragments stops.

**8.12.3** Prevent prolonged exposure to foam. Do not enter foam if full submergence would occur. Both vision and hearing are obscured. Some breathing apparatus can be adversely affected by foam submergence. If wading or moving through foam is necessary, be careful of tripping hazards and always wear a lifeline.

**8.12.4** If possible, do not perform any action which will mechanically degrade that portion of the foam blanket covering the spill that is walking or dragging hoses through foam. Such actions can create a localized vapor hazard. Do not depend on films to rapidly reform and prevent vapor release.

**8.12.5** Where possible, the relative location of foam discharge points to building exits shall be arranged to facilitate evacuation of personnel. Additional exits and other measures may be necessary to ensure safe evacuation of personnel.

**8.12.6** Because foams are made from aqueous solutions, they shall be dangerous to use on materials which react violently with water, such as sodium or potassium, and should not be used when these are present. A similar danger is presented by other metals, such as zirconium or magnesium, only when they are burning.

**8.12.7** Medium and high expansion foams are electrically conductive, and should not be used on energized electrical equipment, where this would be a danger to personnel.

## **9. WETTING AGENTS**

### **9.1 General**

**9.1.1** Experience, as well as tests, has indicated that the addition of a proper wetting agent to water will, when properly applied, increase the extinguishing efficiency of that water with respect to quantity used as well as time saved. The value of such a factor has well become of considerable importance, especially in rural areas where the amount of water available for fire fighting is often inadequate. This is due to the fact that the addition of a proper wetting agent to the charge in a booster tank will increase the extinguishing efficiency of the water.

**9.1.2** Certain types of fires, such as those in baled cotton, stacked hay, some rubber compounds and some flammable liquids, which do not ordinarily respond to treatment with water shall be extinguished when a proper wetting agent is used. This property is attributed to an increase in the penetrating, spreading and emulsifying powers of water due to such factor as lowering the surface tension. This decreased surface tension can be described as a disruption of the forces holding the surface film of water together, thereby permitting it to flow and spread uniformly over solid surfaces. As a result, the treated water acquires the ability to penetrate into small openings and recesses which water would flow over by the simple bridging action of the surface film. It is to be noted that such solutions exhibit not only penetrating and spreading qualities, but increased absorptive speed and superior adhesion to solid surfaces.

**9.1.3** Wetting agents having foaming characteristics as referred to in this Standard, when mixed with water and air, produce a foam which retains the wetting and penetrating characteristics of the wetting agent and provides an efficient smothering action for the extinguishment of both Class A and Class B combustibles or provides a fluid insulation for protection against fire exposure. The foam produced in this manner has the additional advantage of breakdown at approximately 79.4°C and returns to its original liquid state retaining the penetrating and wetting qualities. The breakdown of this foam when applied on Class A combustibles automatically provides an efficient and adequate application rate for efficient extinguishment.

**9.1.4** There are numerous chemicals which fulfill the primary function of a wetting agent, which is to lower the surface tension of water.

**9.1.5** However, very few of these chemicals are suited to fire control work because application to this purpose is complicated by such considerations as toxicity, corrosive action on equipment and stability in naturally occurring waters.

**9.1.6** In view of this fact, therefore, these standards set forth certain basic requirements and limitations for the use of a wetting agent as an aid for fire extinguishment. The requirements are intended to insure that the addition of a wetting agent to any natural water shall not affect that water adversely with respect to fire fighting properties, nor render it harmful to personnel, property or equipment. It is further intended to establish standards for the evaluation of wetting agents as fire extinguishing mediums.

## **9.2 Uses**

**9.2.1** In general, this standard is intended to signify that a wetting agent which successfully meets the requirements herein set forth shall not be limited in use or application except as herein specified.

**9.2.2** The addition of proper wetting agents to water will increase its penetrating and emulsifying abilities and shall provide foaming characteristics as to extend the efficiency of water for the protection against fire exposure and the extinguishment of Class A and Class B fires in ordinary combustibles and combustible liquids which are insoluble in water and ordinarily stored at atmospheric temperatures and pressures.

**9.2.3** In general, wetting agents can be effectively applied and used with all types of standard fire protection equipment where water is normally used. The degree of efficiency obtained will depend on utilizing the most efficient application methods, techniques, and devices for the hazard involved.

**9.2.4** When water containing listed wetting agents is applied to a fire, some of the wetting agent shall be expected to remain after extinguishment. This residual wetting agent is effective in reducing the surface tension of water which will subsequently be applied.

**9.2.5** The I.P. authorities shall be consulted in all cases where the use of wet water is considered for application through fixed equipment, such as water spray, sprinkler, or foam systems. The volume of extinguishing medium required will vary with each type of system and hazard. If applied as a liquid solution, the standard applicable to water systems shall apply.

**9.2.6** Effective exposure protection can be accomplished by the application of wet water foam directly to the exposed structure or equipment to reduce the heat transferred from the exposure fire.

This protection is afforded whether applied from portable or fixed equipment. Due to the cellular structure and reflective characteristics of wet water foam, the water requirements can be appreciably reduced.

**9.2.6.1** The addition of wetting agents to water will increase the efficiency due to the spreading characteristics of the wetting agent, thus affording greater protection than water.

## **9.3 Limitations**

**9.3.1** The addition of wetting agents to water, which changes its physical characteristics, creates certain limitations for use which shall be recognized.

### **9.3.2 Class A fires**

Wet water has the same limitations as water with respect to extinguishing fires involving chemicals that react with water to create new hazards.

### **9.3.3 Class B fires**

The effective use of wet water for the extinguishment of fires involving Class B flammable or combustible liquids is limited to those materials not soluble in water, such as petroleum products. In water soluble materials of the alcohol type, some control should be realized, but extinguishment is questionable.

### **9.3.4 Class C fires**

Wet water solutions can conduct electricity and have limitations similar to water in fighting fires involving energized electrical equipment so far as safety to fire fighting personnel is concerned. Application as a straight stream shall not be considered. Spray or fog application can be employed with usual caution.

### **9.3.5 Wet water shall not be used on Class D fires**

### **9.3.6 Use of wetting agents with other than water**

**9.3.6.1** Admixing of wetting agents with other wetting agents or with mechanical or chemical foam liquids shall be avoided. The mixing of these agents have adverse results and thus render them ineffective for fire extinguishment.

**9.3.6.2** Should wetting agent solution come in contact with electrical equipment, the wetting agent can remain behind after the water has dried off and can constitute a hazard when the equipment is put back in operation.

**9.3.6.3** The mixing of these agents can have adverse effects and render solutions or systems ineffective for fire extinguishment.

**9.3.7** The use of wetting agents in concentrations greater than those specified by the manufacturer and/or by the testing laboratory shall be avoided. High concentrations cause adverse effects.

## **9.4 Basic Requirements**

**9.4.1** Wetting agents for fire fighting shall be listed by a testing laboratory.

**9.4.2** Special equipment, such as proportioners, shall be listed by a testing laboratory.

**9.4.3** For detail of test methods, refer to English version of DIN EN 13565-1 "Fixed firefighting systems – Foam systems"

Part 1: Requirements and test methods for components.

## **9.5 Fire Department Supply Requirements**

**9.5.1** The wetting agent shall be premixed in a booster tank in such concentration as specified by the manufacturer. Where such premixing is considered undesirable, an amount of wetting agent determined to be sufficient for the water contained in the portable tanks on the apparatus shall be carried in a container which can readily be emptied into such tanks.

**9.5.2** Where portable tanks are not a part of the apparatus, or where it is desired to carry the wetting agent separately for use either with water from portable tanks or with water from other sources of supply, the amount considered necessary shall be carried in a suitable tank connected to appropriate proportioning equipment on the apparatus. Where such equipment is used also to take suction from a hydrant supplied by potable water, extra care shall be exercised to prevent contamination of such potable water supplies with wetting agent.

### **9.5.3 Additional supplies**

Additional supplies of wetting agent will be needed to insure continuity of operation and this shall be carried on the apparatus. Further supply shall be stocked in suitable storage facilities to recharge the apparatus.

**9.6 Fixed Systems**

**9.6.1** Existing standards covering all fixed systems shall be followed where the addition of a wetting agent to the system is contemplated. Such installations shall be approved by the I.P authorities with consideration being given primarily to limitations outlined in 9.3 and to:

- a)** The possibility of increased water damage due to the high absorption ability of wet water.
- b)** The possibility of increased floor loads due to the retention of large volumes of wet water.

---

**APPENDICES****APPENDIX A  
CLASSIFICATION OF FOAM CONCENTRATES****Note:**

Foam concentrates are liquids, usually aqueous solutions, which are mixed with water to produce the foam solution used to make foam.

Foam concentrates are generally classified by composition, and for the purposes of this Standard are as described in this Appendix (see 15.1 of B.S. 5306 Section 6.1).

**A.1 PROTEIN**

Protein (p) foam concentrates are aqueous solutions of hydrolyzed protein and are generally used at 3% and 6% concentration.

**A.2 FLUOROPROTEIN**

Fluoroprotein (FP) foam concentrates are protein foam concentrates with added fluorinated surface active agents. The foam is generally more fluid than protein foam, gives faster control and extinction of the fire, and has greater ability to reseal if the foam blanket is disturbed. Fluoroprotein foam is resistant to contamination by hydrocarbon liquids and is generally used at 3% or 6% concentration.

**A.3 FILM-FORMING FLUOROPROTEIN**

Film-forming fluoroprotein (FFFP) foam concentrates are foam concentrates with added fluorinated surface active agents. The foam is more fluid than both protein and standard fluoroprotein foams. The foam is resistant to contamination by hydrocarbon liquids. The solution is film-forming on some liquid hydrocarbon fuel surfaces and is generally used at 3% or 6% concentration.

**A.4 SYNTHETIC**

Synthetic(S) foam concentrates are solutions of hydrocarbon surface active agents. Fluorinated surface active agents if present are present in amounts which do not lead to film-forming on hydrocarbon liquids. Synthetic foam concentrates are generally used at a concentration between 1% and 6% . They are not generally used in low expansion foam system and are not considered in this Standard.

**A.5 AQUEOUS FILM-FORMING**

Aqueous film-forming (AFFF) foam concentrates are generally based upon mixtures of hydrocarbon and fluorinated hydrocarbon surface active agents. Foam solutions made from fluorochemical concentrates are film-forming on some liquid hydrocarbon fuel surfaces and are generally used at 1%, 3% or 6% concentration.

**A.6 ALCOHOL RESISTANT**

Alcohol resistant (AR) foam concentrates are formulated for use on foam destructive liquids; the foams produced are more resistant than ordinary foams to breakdown by the liquid. They may be of any of the classes given in A.1 to A.5 and may be used on fires of hydrocarbon liquids with a fire performance generally corresponding to that of the parent type. Film-forming foams do not form films on water miscible liquids. Alcohol resistant foam concentrates are generally used at 6% concentration on water miscible fuels, and at 3% or 6% concentration on hydrocarbon fuels.

**APPENDIX B  
DETERMINATION OF APPLICATION RATE (MEDIUM EXPANSION)  
AND FOAM DISCHARGE RATE (HIGH EXPANSION)**

**B.1 APPARATUS**

**B.1.1** Pressure gage, installed adjacent to the discharge point in the hydraulically most remote location, with respect to the main foam solution supply line to the system.

**B.2 PROCEDURE**

Discharge the system and record the steady state discharge pressure (P) at the nozzle. Visually examine all discharge points to see that they are operating satisfactorily. Sample the foam from the most remote nozzle to measure expansion and drainage in accordance with Appendix C.

**B.3 CALCULATION**

**B.3.1 Medium Expansion Foam**

Calculate the overall foam solution flow rate (**Q**) (in L/min) where only one type of nozzle is used from the equation:

$$Q = \sum^n N \times K \times P^{0.5}$$

**Where:**

- Q** is the foam solution flow rate (inL/min);
- K** is the nozzle discharge coefficient;
- N** is the number of nozzles fitted;
- P** is the steady state nozzle pressure (in bar);

or where more than one type of nozzle is fitted, from the sum of the overall rates for each type of nozzle, given by the equation:

$$Q = \sum^n N \times K \times P^{0.5}$$

**Where:**

**n** is the number of types of nozzle.

Calculate the application rate R (in L/m<sup>2</sup> per minute) from the equation:

$$R = \frac{Q}{A}$$

**Where:**

**A** is the area covered by the system (in mm<sup>2</sup>)

**Note:**

**The discharge coefficients are determined by separate tests of the nozzles concerned measuring flow rates over the pressure range involved.**

**B.3.2 High Expansion Foam**

Calculate the foam solution flow rate in accordance with B.3.1 Calculate the foam discharge rate (in m<sup>3</sup>) from:

$$F = Q \times E$$

**Where:**

**E** is the expansion, determined in accordance with Appendix C.



---

**APPENDIX C****C.3 CALCULATION**

Calculate the foam expansion from the equation:

$$E = \frac{166.2}{W_2 - W_1}$$

**Where:**

$W_1$  is the mass of the empty pan (in Kg);

$W_2$  is the mass of the full pan (in Kg);

The volume of foam is the volume of the pan, 166.25 L, and  $W_2 - W_1$  is the volume of water (equal to the mass of the foam) contained in it.

APPENDIX D  
FOAM CONCENTRATE STORAGE AND UNLOADING FACILITIES

