

ENGINEERING STANDARD

FOR

INSTRUMENTS ELECTRICAL POWER SUPPLY

AND

DISTRIBUTION SYSTEMS

FIRST EDITION

MAY 2013

FOREWORD

The Iranian Petroleum Standards (IPS) reflect the views of the Iranian Ministry of Petroleum and are intended for use in the oil and gas production facilities, oil refineries, chemical and petrochemical plants, gas handling and processing installations and other such facilities.

IPS is based on internationally acceptable standards and includes selections from the items stipulated in the referenced standards. They are also supplemented by additional requirements and/or modifications based on the experience acquired by the Iranian Petroleum Industry and the local market availability. The options which are not specified in the text of the standards are itemized in data sheet/s, so that, the user can select his appropriate preferences therein

The IPS standards are therefore expected to be sufficiently flexible so that the users can adapt these standards to their requirements. However, they may not cover every requirement of each project. For such cases, an addendum to IPS Standard shall be prepared by the user which elaborates the particular requirements of the user. This addendum together with the relevant IPS shall form the job specification for the specific project or work.

The IPS is reviewed and up-dated approximately every five years. Each standards are subject to amendment or withdrawal, if required, thus the latest edition of IPS shall be applicable

The users of IPS are therefore requested to send their views and comments, including any addendum prepared for particular cases to the following address. These comments and recommendations will be reviewed by the relevant technical committee and in case of approval will be incorporated in the next revision of the standard.

Standards and Research department

No.17, Street14, North kheradmand

Karimkhan Avenue, Tehran, Iran.

Postal Code- 1585886851

Tel: 021-88810459-60 & 021-66153055

Fax: 021-88810462

Email: Standards@nioc.ir

GENERAL DEFINITIONS:

Throughout this Standard the following definitions shall apply.

COMPANY:

Refers to one of the related and/or affiliated companies of the Iranian Ministry of Petroleum such as National Iranian Oil Company, National Iranian Gas Company, National Petrochemical Company and National Iranian Oil Refinery And Distribution Company.

PURCHASER:

Means the "Company" where this standard is a part of direct purchaser order by the "Company", and the "Contractor" where this Standard is a part of contract documents.

VENDOR AND SUPPLIER:

Refers to firm or person who will supply and/or fabricate the equipment or material.

CONTRACTOR:

Refers to the persons, firm or company whose tender has been accepted by the company.

EXECUTOR:

Executor is the party which carries out all or part of construction and/or commissioning for the project.

INSPECTOR:

The Inspector referred to in this Standard is a person/persons or a body appointed in writing by the company for the inspection of fabrication and installation work.

SHALL:

Is used where a provision is mandatory.

SHOULD:

Is used where a provision is advisory only.

WILL:

Is normally used in connection with the action by the "Company" rather than by a contractor, supplier or vendor.

MAY:

Is used where a provision is completely discretionary.

CONTENTS:	PAGE No.
1. SCOPE	2
2. REFERENCES	2
3. UNITS	3
4. GENERAL	3
5. CLASSIFICATION	3
6. POWER SUPPLY SPECIFICATION.....	4
7. STAND-BY POWER SUPPLY	5
8. DISTRIBUTION SYSTEM	5
9. WIRING METHODS	7
10. SYSTEM AND EQUIPMENT GROUNDING	7
10.1 Instrument Signal Grounding	7
10.2 Instrument Power supply Grounding	7
10.3 Equipment Grounding	7
APPENDICES:	
APPENDIX A POWER SOURCES	8
APPENDIX B STABILIZING AND DISTRIBUTION SECTIONS.....	10
APPENDIX C METERING FOR D.C. SECTIONS	13
APPENDIX D SYMBOLS.....	14

1. SCOPE

This Standard covers the minimum and general requirements of electrical power supply and distribution system, for all instruments and related equipment within the scope of this Standard.

For materials specifications and installation procedures of different components of electrical power supply such as:

Transformers, circuit breakers, fuses, rectifiers, battery chargers, etc., refer to related electrical standards.

It is intended to be used in oil, gas, and petrochemical industries.

Note 1:

This standard specification is reviewed and updated by the relevant technical committee on Aug. 2005. The approved modifications by T.C. were sent to IPS users as amendment No. 1 by circular No. 278 on Aug. 2005. These modifications are included in the present issue of IPS.

Note 2:

This is a revised version of this standard, which is issued as revision (1)-2013. Revision (0)-1996 of the said standard specification is withdrawn.

2. REFERENCES

Throughout this Standard the following dated and undated standards/codes are referred to. These referenced documents shall, to the extent specified herein, form a part of this standard. For dated references, the edition cited applies. The applicability of changes in dated references that occur after the cited date shall be mutually agreed upon by the Company and the Vendor. For undated references, the latest edition of the referenced documents (including any supplements and amendments) applies.

BP (BRITISH PETROLEUM)

BP RP 12-5 "Electrical Systems and Installations - Power Supplies for Control Systems"

BSI (BRITISH STANDARD INSTITUTION)

BS HD 60269 "Low Voltage Fuses"

BS 646 (1986) "Cartridge Fuse-Links (Rated up to 5A) for A.C. & D.C. Services"

BS 1362 (1986) "General Purpose Fuse Links for Domestic and Similar Purposes (Primarily for Use in Plugs)"

BS EN 60898-1 "Electrical Accessories-Circuit Breaker for Over current Protection for Household and Similar Installations- Part1: Circuit Breaker for ac Operation"

API (AMERICAN PETROLEUM INSTITUTE)

API 552 "Transmission System"

API 554-2 "Process Control Systems- Process Control System Design"

IPS (IRANIAN PETROLEUM STANDARDS)

IPS-E-GN-100	“Engineering Standard for Units”
IPS-E-IN-190	“Engineering Standard for Transmission Systems”
IPS-E-EL-100	“Engineering Standard for Electrical System Design Industrial and Non-Industrial)”
IPS-M-EL-174	“Material and Equipment Standard for Battery and Battery Charger (DC Power Supply)”
IPS-M-EL-176	“Material and Equipment Standard for Uninterruptable Power Supply System (UPS)”
IPS-G-IN-250	“Engineering and Construction Standard for Distributed Control System (DCS)”
IPS-G-IN-290	“Engineering and Construction Standard for Programmable Logic Controllers (PLC)”
IPS-M-IN-250	“Materials and Equipment Standard for Distributed Control System (DCS)”
IPS-M-IN-290	“Materials and Equipment Standard for Programmable Logic Controllers (PLC)”

3. UNITS

This Standard is based on International Systems of Units (SI), as per [IPS-E-GN-100](#) except where otherwise specified.

4. GENERAL

4.1 Instrument power supplies, distribution, installation and use of electricity shall generally conform to electrical section of IPS, but the requirements of this Standard shall take precedence.

4.2 Supply and distribution systems for electrically operated instruments and apparatus shall be designed specifically to achieve reliable operation (see Appendices A through C as typical examples).

4.3 The principle of design reliability applies equally to main distribution systems or to systems incorporating batteries or other power supplies.

4.4 The design of power supply systems shall permit all components to be maintained in safe condition while retaining supplies to the instruments.

4.5 The D.C. power supply units may be operated free from earth (floated), provided that an earth fault detection system is utilized.

5. CLASSIFICATION

5.1 For the purpose of designing a reliable distribution, instruments shall be classified according to the effect on the plant, due to their electrical malfunction or failure:

Class A: Class A systems are defined as those which by malfunction or failure can cause any of the following:

- a)** A shutdown of the whole or major part of a plant or process
- b)** A failure to shut down, under emergency conditions, the whole or major part of a plant or process.

c) A loss of monitoring facilities on any equipment which may itself cause a shutdown of the whole or major part of a plant or process.

d) A loss of alarm annunciation for fire and gas detection

Class B: Class B systems are defined as those which their malfunction or failure can cause any of the following:

A degradation of normal control or monitoring of the plant or process where alternative methods of control, such as local plant control panels, hand wheels etc are available.

A loss of alarm annunciation facilities not Covered by 7.6.1.2

Class C: Apparatus is that by their malfunction or failure cannot directly prevent the operation of the plant. This class comprises of indicators, integrators, recorders and most analyzers.

5.2 The supply to Class A apparatus shall be separate from that of other classes.

5.3 The supply to Classes B and C may be combined if economically justified.

5.4 For more information refer to BP recommended practice RP 12-5 "Electrical Systems and Installations - Power Supplies for Control Systems"

6. POWER SUPPLY SPECIFICATION

6.1 Class A apparatus shall be supplied with a continuous uninterrupted 110 V AC power supply. For these cases parallel dual redundant UPS shall be used. For more information refer to [IPS-E-EL-100](#). The system shall provide backup power for a minimum of 2 hours within the specified limits at the worst ambient conditions and at maximum demand.

Other supply voltages and time limits may be considered by user approval.

6.2 Class B apparatus shall be provided with a power supply which meets system requirements with respect to reliability, characteristics and freedom from interference, both radiated and entering from the external power source.

An alternative source of electrical power shall be provided to supply critical instruments and associated equipment in the event of failure of the normal power supply. (see Appendices A through C).

The supply shall continue in operation after an external power failure for as long as any part of the plant requires retention of the process control system. This time shall nominally be one hour or as otherwise agreed by the user.

There shall be no unacceptable break or transient deterioration of the process control due to failure of either the external power source or of any module which is protected by redundancy. This does not necessarily preclude the use of manually started stand-by systems if agreed by the user.

6.3 Class C apparatus shall be provided with a power supply from normal mains sources, without any stand-by, but the supply may be taken from sources supplying Class B apparatus where this arrangement is economically justified.

Instrument power supplies shall be from a single source, and in general, shall be isolated from power and lighting supplies to reduce the effect of load changes, switching transient and human switching errors. Instruments installed in remote isolated locations may be connected to lighting or local power supplies by agreement with the user.

6.4 The power supply apparatus shall remain within its specified limits under the following environmental conditions:

a) Ambient temperature range -15°C to 52°C or as specified by the user.

b) Relative humidity up to 95%.

6.5 In the case of telemetry and data processing equipment it may be economically and technically

justifiable to install separate power supply apparatus to feed the general process instrumentation.

6.6 For power quality specification refer to [IPS-G-IN-290](#), [IPS-M-IN-290](#), [IPS-G-IN-250](#), [IPS-M-IN-250](#).

7. STAND-BY POWER SUPPLY

7.1 It shall be possible to change over automatically (with alternative manual operation) from normal to stand-by and vice versa while on load. (See Appendices A through C.)

Some equipment may require continuous power supply; in this case static transfer switch may be utilized.

7.2 Normally, on plants equipped with pneumatic instruments, delays inherent with commissioning the stand-by generator from rest may be tolerated. On plants equipped with electronic instruments, especially in cases where control equipment is finally hydraulically or electrically operated, "Limited Break", "No break" or other forms of stand-by supply system which will provide power within a safe time limit shall be used.

7.3 Design shall provide for periodic testing of emergency power systems without upsetting plant operation.

7.4 Annunciator shall be provided to indicate the state of the major units of the normal and stand-by power supply system. A battery should be provided with charge-fail and low battery voltage annunciators. Any float charging system should be so designed that it will fully re-charge the battery under all conditions of load. The use of batteries requiring high boost voltages shall be avoided.

7.5 A method of test shall be provided to enable stand-by batteries to be checked for storage capacity while the normal power supply is operating. See the relevant electrical standards of IPS.

7.6 The capacity of batteries shall be calculated at the lowest operating temperature and shall exclude the capacity of the battery remaining at the end voltage being determined by the connected apparatus.

8. DISTRIBUTION SYSTEM

8.1 Miniature circuit breakers or fuses as specified by the user shall be utilized.

8.2 A.C. distribution systems shall be fused so as to maintain high integrity of supply by proper discrimination of fault level. The sub-circuits to Classes B and C instruments shall be segregated and fused separately.

8.3 The primary fuse clears faults in the primary feed, the transformer and in the secondary distribution board.

The secondary sub-circuits from this distribution board are segregated into Classes B and C sub-circuits. They are fused individually. Each class of sub-circuit covers separate sub-circuits feeding separately operable sections of the control system, corresponding to working sections of the plant.

A secondary circuit supplying one item only, and fed from a transformer shall not be fused.

8.4 The supply shall have a sufficient regulation to feed into a fault without dropping the voltage to an unacceptable level, while the faulty circuit is cleared by its protecting fuse.

8.5 When A.C. supplies are employed it must be established that output of the supply is compatible with any built-in voltage regulating systems in instruments intended to be connected to an unregulated power source. If necessary the latter should be used and other steps taken to provide continuity of operation.

8.6 Main supply transformers shall be of the double wound type with at least one earthed screen between the primary and secondary windings. The primary winding of the transformer shall be protected by an appropriately rated H.B.C. (High Breaking Capacity) fuse. The secondary shall

have one pole earthed at the transformer only.

Transformers shall be compatible with instrument manufacturer's requirements. If supplies do not have the necessary degree of voltage stability, constant voltage transformers may be used to meet this requirement.

8.7 A secondary sub-circuit feeding more than one instrument loop should be arranged as a main ring. All instruments of a single control loop shall be fed by one fused spur from the main ring. Each control loop shall have its own fuse.

8.8 The fuse of any individual spur shall be rated at three times the normal load current, and not less than 2 amps.

8.9 A sub-circuit or ring fuse shall be rated at twice the total connected load. It shall also have three times the rating of the largest spur fuse connected to the ring.

8.10 The rated power of any secondary sub-circuit fuse shall not exceed one-third of the primary power rating in VA.

8.11 Where instruments, being part of a loop, are fitted with internal power supply fuses, these should normally be removed, subject to manufacturer's agreement, and the circuit made good. Instruments connected individually to the main ring shall be fused as spurs.

8.12 Fuse links of different ratings shall be positively identified.

8.13 Primary and secondary sub-circuit fuses shall comply with BS HD60269.

Those for spurs or individually connected instruments shall comply with BS 646 and BS 1362.

8.14 Miniature circuit breakers shall comply with BS EN 60898, or any other equivalent standard.

8.15 Each Class A emergency shut down device shall be supplied with an individual switch-fuse unit.

8.16 The power supply to individual instruments installed external to control houses shall be connected through a switch-fuse unit which may be mounted adjacent to the instrument and suitable for the particular area classification relevant to their location.

8.17 The distribution system protection shall be designed to discriminate between fault levels in individual protected zones. In general, fuses or miniature circuit breakers should be used to protect the distribution system against overload, rather than protect the instrument from damage.

8.18 Isolation of individual instruments shall be possible either by a switch or by opening of a miniature circuit breaker. In any single current circuit there shall not be more than one fuse in series.

8.19 Generally, a maximum of six recorders or indicator may be connected to one switch-fuse unit. Multipoint electronic recorders, analyzers and controllers shall be connected through individual switch fuses unless supplied with approved integral isolating devices, when up to three controllers may be connected to one switch-fuse unit. Switch fuse units shall be suitable for the particular area classification relevant to their location.

For digital instrumentation systems, separate branch circuit shall be provided for each sub-system.

8.20 Branch circuit breakers may be single-pole in the ungrounded lead.

8.21 A branch circuit directory identifying each circuit and all instruments associated with each circuit shall be provided at each branch circuit panel board or equipment cabinet containing more than one circuit breaker or fuse.

8.22 Power distribution centers shall incorporate 15% spare branch circuit disconnect switches.

8.23 Plugs and receptacles may be used as the disconnecting means if the equipment is located in an area classified as "non-classified".

8.24 A branch circuit disconnect switch shall be single-pole in the fused ungrounded lead (Grounded lead shall not be fused). The switch shall be connected before the fuses.

8.25 Branch circuit protection for process stream analyzers shall also include the following:

- a) The power for all devices associated with a given analyzer system shall be supplied from

the same source, and each system shall have a single disconnect switch for the entire system. In addition, disconnect switches shall be installed to permit isolation of each device in an analyzer system.

b) Each field mounted analyzer device shall have a local disconnect switch.

8.26 Disconnect switch enclosures for field use should be explosion proof in hazardous area, unless otherwise specified.

9. WIRING METHODS

9.1 The actual circuit requirements for the individual instrument shall be determined by the type of instrument being served and is a part of the system design. [IPS-E-IN-190](#) "Transmission Systems" discusses wiring requirements as well as grounding and shielding requirements in detail.

9.2 Wiring methods as per electrical standards of IPS for power wiring shall be used. Attention must be paid to special requirements, which are a result of the circuit function. For instance, special attention shall be paid to routing, safety, control and shut down circuits. It is desirable to segregate these circuits from normal circuit routes to prevent a fire, explosion, or other accident from disabling critical circuits. It may be necessary to route underground or fireproof the exposed components of these circuits to preserve circuit integrity during a fire.

10. SYSTEM AND EQUIPMENT GROUNDING

10.1 Instrument Signal Grounding

Power supply, equipment, and instrument signal grounds shall not be interconnected. Generally, instrument signal cable shields are grounded on an isolated bus that is connected to a separate ground. The exception can be thermocouple shields, which in many instances are grounded in the field at the thermocouple head.

10.2 Instrument Power supply Grounding

Instrumentation power shall be supplied from a transformer that is dedicated to instruments only. The transformer serves as an electrical isolating device as well as transforming the voltage to the proper utilization level. If the transformer has a Y-connected secondary, then the neutral should be solidly grounded. On a 220/380 volt three-phase transformer, the 220 volt phase to neutral is used to serve most instrument requirements. The 380 volt phase to phase can be used for larger loads, such as computers or common D.C. power supplies.

The solid ground neutral holds fixed the phase to neutral voltage and provides a return path for a phase to ground fault that allows ground fault sensing devices to quickly isolate the faulted circuit.

10.3 Equipment Grounding

When there is unintentional contact between an energized circuit or conductor and a metal structure or housing that encloses it, the structure or housing tends to become energized at the voltage level of the energized circuit or conductor.

To prevent shock hazard when this occurs, non-current carrying components such as frames and racks must be solidly grounded to earth by a low impedance path, such as a ground conductor connecting to a ground well. This will also minimize conducting paths, or ground loops, that may be inductively or capacitively coupled to the instrument signal circuits. Again, the equipment ground must not be interconnected to the instrument signal ground bus. It is acceptable to connect the equipment ground to the power supply ground well. It is recommended that a grounding conductor connect the equipment directly to the ground well to ensure a low impedance ground path.

APPENDICES

**APPENDIX A
POWER SOURCES**

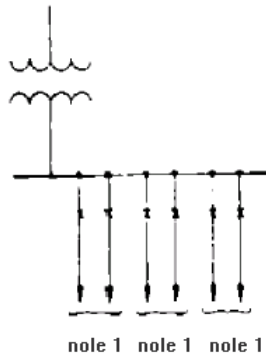

(a)

When standby generator is not required and instrument power supply is for instrumentation of units fed by a single radial substation

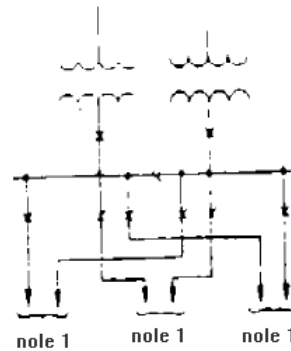

(b)

When standby generator is not required and instrument power supply is for instrumentation of units fed by single spot network or secondary selective substation.

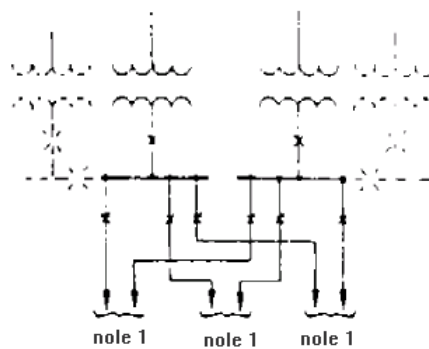

(c)

When standby generator is not required and instrument power supply is for instrumentation of units fed by two or more substations.

(to be continued)

APPENDIX A (continued)

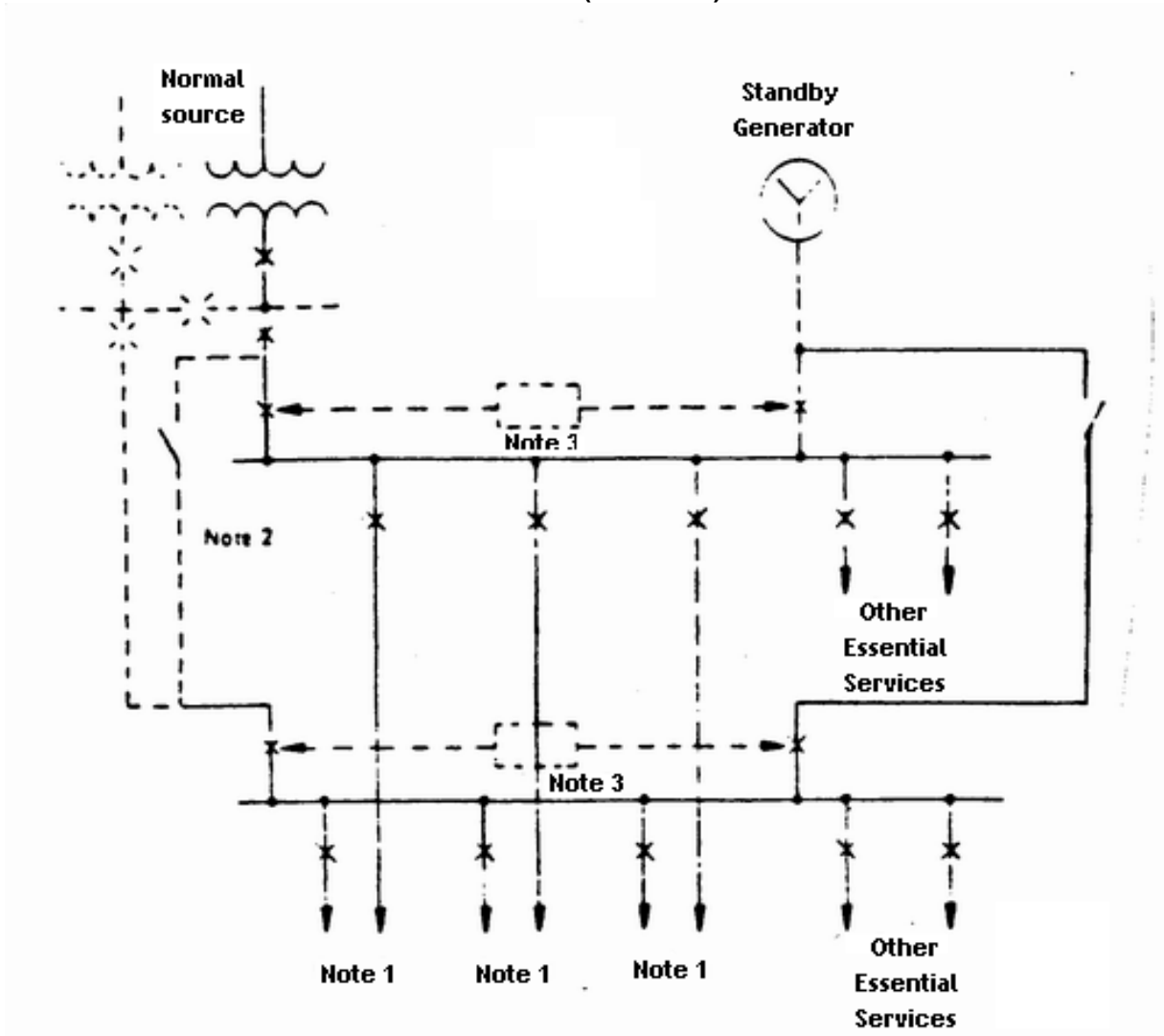

(d)

When standby generator is required normal source to instrument power supply shall be taken from separate busses when supply is for facilities fed by spot network or secondary selective substations.

Notes:

- 1) To stabilization sections of Appendix B.
- 2) Tie cable and switch between busses used only when normal source is single feeder from radial sub-station.
- 3) Essential services switchgear with automatic transfer.

APPENDIX B
STABILIZING AND DISTRIBUTION SECTIONS

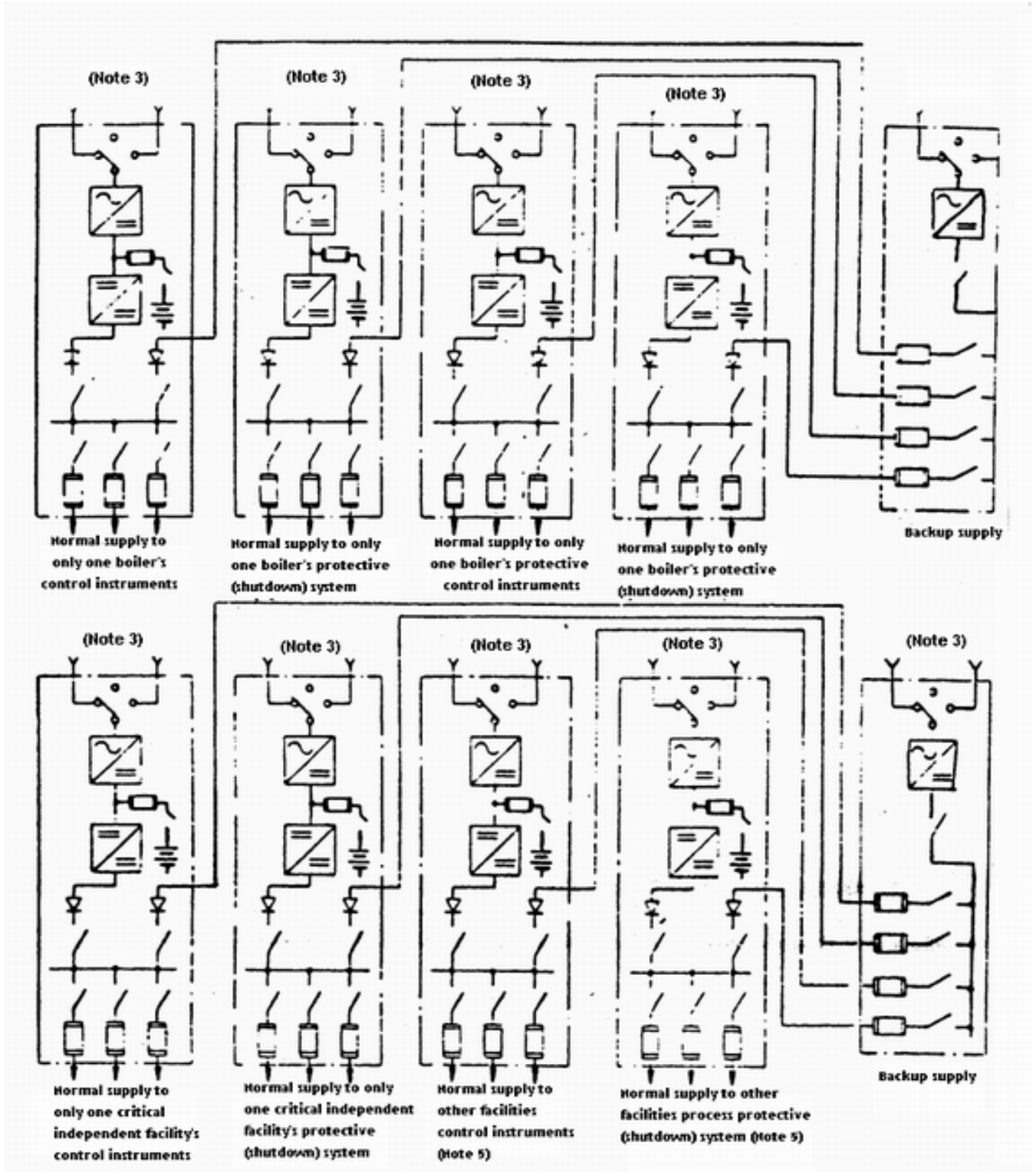

(a) For d.c. Load

(to be continued)

APPENDIX B (continued)

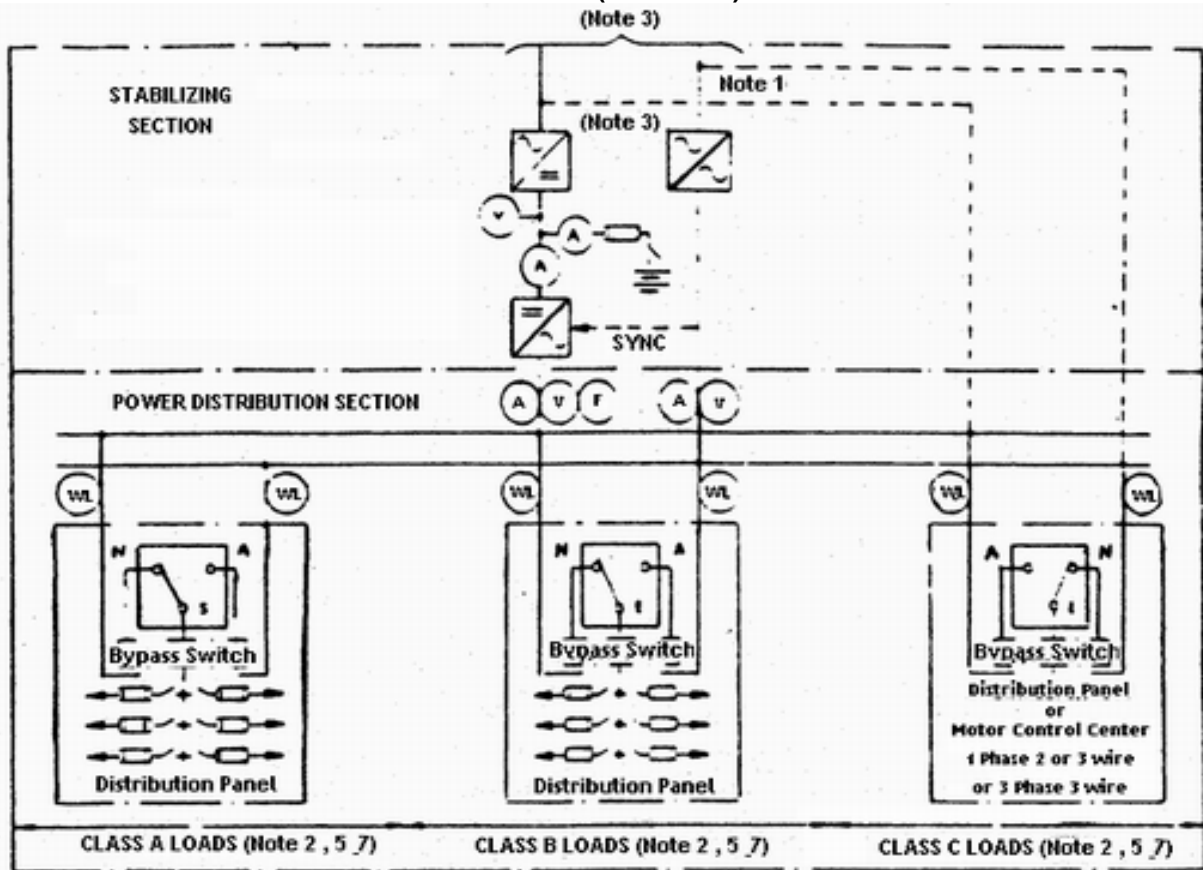

(b) For A.C. Loads

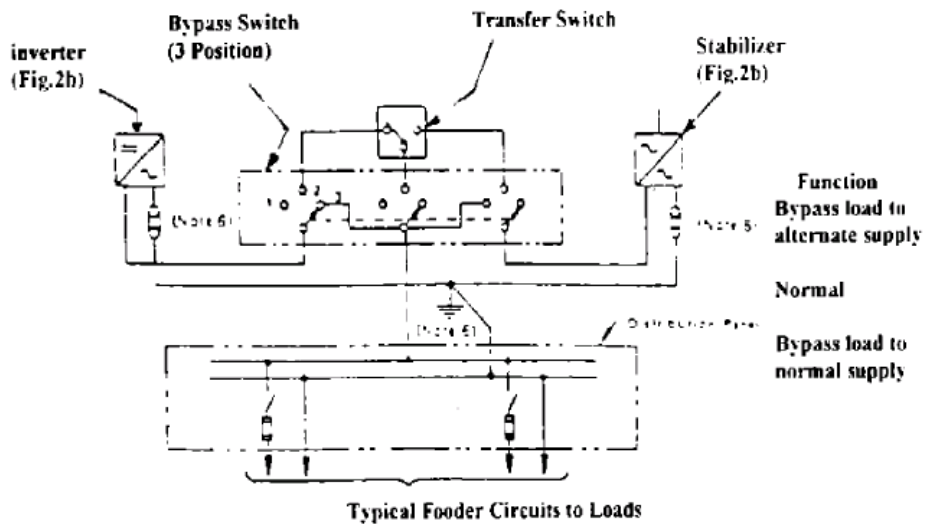

(c) Bypass Switch and Neutral Grounding Details

(to be continued)

APPENDIX B (continued)**Notes:**

- 1) Alternative connection for Class C loads if they are compatible with main supply voltage and frequency deviations.
- 2) Delete if not required.
- 3) From main supply in Appendix A provide step-down transformers if required.
- 4) Alternative connection for Class C loads if auxiliary generator is included in power source section and loads are compatible with main supply voltage and frequency deviations.
- 5) Provide separate feeder circuits from distribution panels for each facility.
- 6) Solidly ground the neutral of the A.C. system at only one point on the load side of the inverter and A.C. voltage stabilizer. Provide accessible links or connection points at the output of the inverter and stabilizer to permit removing the neutral ground during testing.
- 7) Provide single pole switching devices for 2 wire single-phase grounded neutral systems.

**APPENDIX C
METERING FOR D.C. SECTIONS**

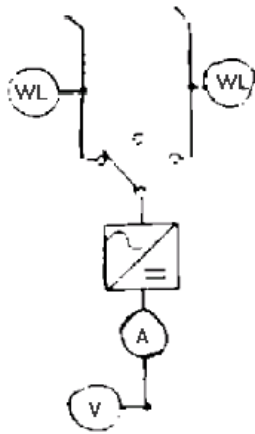



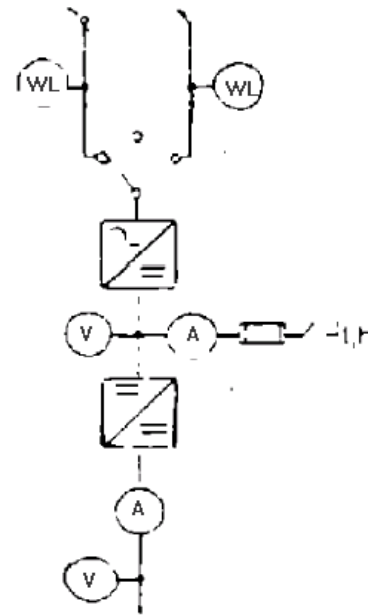

























(a) Metering for D.C. Backup Supplies



(b) Metering for D.C. Stabilizing

APPENDIX D
SYMBOLS

(used herein, not mandatory for vendor)

SINGLE LINE DIAGRAMS	SCHEMATIC DIAGRAMS
 POWER TRANSFORMER	 DISCONNECT SWITCH
 POTENTIAL TRANSFORMER	 FUSE
 CURRENT TRANSFORMER	 RESISTOR
 CIRCUIT BREAKER	 INDICATING LAMP <small>GL GREEN RL RED WL WHITE</small>
 FUSE	 CONTACT OPEN WHEN DEVICE IS OPEN (DEENERGIZED OR IN NORMAL POSITION)
 DISCONNECTING DEVICE	 CONTACT CLOSED WHEN DEVICE IS OPEN (DEENERGIZED OR IN NORMAL POSITION)
 RELAY OR METER COIL	 COIL OF RELAY OR SOLENOID
 METER TRANSFER SWITCH	 CROSSED LEADS (NO CONNECTION)
 PROTECTIVE DEVICE (FUSE OR CIRCUIT BREAKER)	 CONNECTED LEADS
 AUTOMATIC TRANSFER SYSTEM (SEE FIGURE 2 FOR DETAILS)	
 GENERATOR	
 BATTERY CHARGER OR RECTIFIER	
 INVERTER	
 AC VOLTAGE STABILIZER	
 DC VOLTAGE STABILIZER	
 TRANSFER SWITCH <small>E ELECTROMECHANICAL S SOLID STATE N NORMAL SUPPLY A ALTERNATE SUPPLY</small>	
 STORAGE BATTERY	
 DISCONNECT SWITCH AND FUSE	
 MANUAL SELECTOR SWITCH	
 LINK	
	FUNCTIONS <small>(used herein, not mandatory for vendor)</small>
	10 TRIP SELECTOR SWITCH
	24 LOAD BREAK SWITCH
	25 SYNCHRONIZING RELAY
	25X AUXILIARY RELAY
	27 TIME UNDERVOLTAGE RELAY
	27I INSTANTANEOUS UNDERVOLTAGE RELAY
	51 TIME OVERCURRENT RELAY (MAY BE INVERSE TIME FOR 51I, BUT MUST BE INDEPENDENT TIME FOR 51I)
	57 AIR CIRCUIT BREAKER, DRAWOUT
	59 OVERVOLTAGE RELAY
	81 UNDER FREQUENCY RELAY
	88 LOCKOUT RELAY, HAND RESET
	V VOLTMETER
	A AMMETER
	PF POWER FACTOR METER
	KW KILOWATT METER
	F FREQUENCY METER
	VS VOLTMETER TRANSFER SWITCH
	AS AMMETER TRANSFER SWITCH