

MATERIAL AND EQUIPMENT STANDARD

FOR

AVIATION TURBINE FUEL STORAGE TANKS

ORIGINAL EDITON

MAY 1993

This standard specification is reviewed and updated by the relevant technical committee on Jan. 1999. The approved modifications are included in the present issue of IPS.

CONTENTS :	PAGE No.
0. INTRODUCTION	2
1. SCOPE	3
2. REFERENCES	3
3. UNITS	3
4. QUOTATION	3
5. SECRECY	3
6. DESIGN	4
7. MATERIAL	4
8. FABRICATION	5
9. ERECTION AND PREPARATION FOR SITE ERECTION	5
10. WELDING	5
11. INSPECTION AND TEST	5
12. SUPPLEMENTARY REQUIREMENTS	5
13. PACKAGING	6
14. SHIPMENT	6
15. GUARANTEE	6
 APPENDICES	
APPENDIX A QUOTATION	7
APPENDIX B SECRECY	8
APPENDIX C PACKING	9
APPENDIX D SHIPMENT	11
APPENDIX E GUARANTEE	12
APPENDIX F STORAGE TANK DATA SHEET	13

0. INTRODUCTION

"Storage Tanks are broad and contain variable types and usages of paramount importance therefore, a group of Material Standards are prepared to cover the subject. This Group includes the following Standards:

STANDARD CODE

STANDARD TITLE

[IPS-G-ME-100](#)

"Atmospheric Above Ground Welded Steel Storage Tanks"

[IPS-M-ME-110](#)

"Large Welded Low Pressure Storage Tanks"

[IPS-M-ME-120](#)

"Aviation Turbine Fuel Storage Tanks"

[IPS-M-ME-130](#)

"Pressure Storage Spheres (For LPG)"

The requirements of this standard specification are supplementary to Appendix H of API 650 1988 edition and [IPS-G-ME-100](#) Standard and take precedence where particular requirements differ from those outlined in the above specifications. For ease of reference, the Clause or Section numbering of API 650-88 (Appendix H) for the items supplemented are given at the beginning of each paragraph. Clauses in API Std. 650 not mentioned remain unaltered.

This Standard Specification gives general requirements to be met by a vendor when submitting quotations for and when supplying the materials to be incorporated into the aviation turbine fuel storage tanks. Furthermore, the terms and conditions laid down in the inquiry and in the purchase order and any attachment thereto shall apply.

For the purpose of this specification, the following definitions shall hold:

- Sub. (Substitution)** : The API Std. Clause is deleted and replaced by a new clause.
- Del. (Deletion)** : The API Std. Clause is deleted without any replacement .
- Add. (Addition)** : A new clause with a new number is added.
- Mod. (Modification)** : Part of the API Std. Clause is modified, and/or a new description and/or condition is added to that clause.

1. SCOPE

This material and equipment standard, covers the minimum requirements for the material of aviation turbine fuel storage tanks, designed and constructed in accordance with Appendix H of API standard 650-88.

This Standard Specification is to be used in conjunction with [IPS-G-ME-100](#) Standard and Appendix H of API

650-88.

Note:

This standard specification is reviewed and updated by the relevant technical committee on Jan. 1999. The approved modifications by T.C. were sent to IPS users as amendment No. 1 by circular No 53 on Jan. 1999. These modifications are included in the present issue of IPS.

2. REFERENCES

Throughout this Standard the following dated and undated standards/codes are referred to. These referenced documents shall, to the extent specified herein, form a part of this standard. For dated references, the edition cited applies. The applicability of changes in dated references that occur after the cited date shall be mutually agreed upon by the Company and the Vendor. For undated references, the latest edition of the referenced documents (including any supplements and amendments) applies.

API (AMERICAN PETROLEUM INSTITUTE)

API 650-88 "Welded Steel Tanks For Oil Storage-Appendix H"

ANSI (AMERICAN NATIONAL STANDARD INSTITUTE)

ANSI B1.1. "Unified Inch Screw Threads"

IPS (IRANIAN PETROLEUM STANDARDS)

[IPS-E-GN-100](#) "Units"

[IPS-C-ME-110](#) "Large Welded, Low Pressure Storage Tanks"

[IPS-G-ME-100](#) "General Standard for Atmospheric Storage Tanks"

3. UNITS

International system of units (SI) in accordance with [IPS-E-GN-100](#) shall be used.

4. QUOTATION (Add.)

Refer to Appendix A of this Standard for general information to be submitted in the quotation.

5. SECRECY (Add.)

Refer to Appendix B of this Standard for secrecy requirements.

6. DESIGN

6.1 Storage tanks for aviation turbine fuel shall be designed in accordance with Appendix H" Internal Floating Roofs" of API Standard 650-88 "Welded Steel Tank for Oil Storage" 8th edition. Also the requirements of Iranian Petroleum Engineering Standard for Aviation Turbine Fuel Storage Tanks ([IPS-E-ME-120](#)) shall be fulfilled. Supplementary requirements are as follow:

6.2 (H.4 Add.)

A floating suction of approved design and compatible with the floating deck is mandatory. The main object of fitting is to minimize the risk of contamination by water.

6.3 (H.4.1 Add.)

Any part for which no drawing have been prepared shall be designed by Vendor on the basis of the above mentioned reference standards.

6.4 (H.4.1 Add.)

The tank inlet line shall have an inlet extension pipe to minimize turbulence during high tank filling.

6.5 (H.4.1 Add.)

The design of aviation fuel storage tanks, the type with a floating cover inside a fixed roof tank, designed as a non pressure tank, is recommended to be limited to maximum diameter of 39 meters.

7. MATERIAL

7.1 Material selection for aviation turbine fuel storage tanks shall be in accordance with section H3 of Appendix H of API standard 650-88 modified and amplified by the following paragraphs.

7.2 (H.3.5.8 Add.)

Materials other than those specified in API 650-88 may be used while their chemical analysis and physical properties are identified and upon approval of the purchaser.

7.3 (H.3.5.9 Add.)

Mill chemical analysis and mechanical test certificates are required for bottom and shell plates, wind girders, pipes and flanges and seal material. Roof plates and other materials require mill certificates only.

7.4 (H.3 Add.)

Sealing materials, if used, to make joints in panels or sections should be compatible with the product contained.

7.5 (H.3.3 Add.)

All fasteners in contact with the product contained or product vapor shall be of stainless steel or aluminum.

7.6 (H.3.1 Add.)

Bolt and nut thread shall conform to ANSI B1.1 coarse series Class 2A and 2B respectively.

7.7 (H.3.5.10 Add.)

Where connections are made to external piping, the material and all other requirements for nozzles, flanges, bolting, gasketing and pipe shall be met as specified in that piping class.

7.8 (H.3.5.11 Add.)

Vendor shall supply all welding rods required to fabricate the tank. Consideration shall be given to Iranian supply of rods where those conform to the material required.

8. FABRICATION

8.1 All works of fabrication of materials intended to be incorporated into the aviation turbine fuel storage tanks shall be in accordance with Section 7 of [IPS-G-ME-100](#) Standard and Part H.7 of Appendix H of API Standard 650-88.

9. ERECTION AND PREPARATION FOR SITE ERECTION

9.1 Field erection of aviation fuel storage tanks shall be in accordance with Section 5 of API Standard 650 and Iranian Petroleum Construction Standard for Aviation Turbine Fuel Storage Tanks ([IPS-C-ME-110](#)).

9.2 (H.7.5 Add)

The responsibility for the supply of site erection equipment, labor, false work, etc. lies with the erection contractor.

10. WELDING

10.1 Aviation turbine fuel storage tanks and their parts shall be welded according to Section 5.2 and 7 of API Standard 650 and the supplementary requirements of Section 9 of [IPS-G-ME-100](#) Standard shall be fulfilled. Additional requirements are as follows:

10.2 (H.4.3.5 Add)

All internal bulkhead plates or sheets shall be single fillet welded along their bottom and vertical edges so that they are liquidtight. When pontoon or double deck roofs are required, the top edge of each bulkhead shall also be provided with a continuous single fillet weld so that it is liquidtight.

10.3 Joint design for aviation fuel tanks shall be in accordance with Section H.4.3 of Appendix H of API Standard 650-88.

11. INSPECTION AND TEST

11.1 Shop inspection of materials to be incorporated into aviation fuel storage tanks and inspection of their welding joints shall be in accordance with Sections 4.2 and 6 of API Standard 650-88 respectively. Supplementary requirements of Section 10 of [IPS-G-ME-100](#) Standard shall be fulfilled. In addition, the requirements of Section H7 (part H.7.2) of Appendix H of API 650-88 shall be met.

11.2 (H.7.6 Add.)

All shop fabricated pontoons (or buoyancy compartments) shall be pressure leak tested with a soap type detecting solution or by any other approved method consistent with the design.

12. SUPPLEMENTARY REQUIREMENTS (Add.)

12.1 Vendor shall send final issues of all drawings mentioned under 7.2 of [IPS-G-ME-100](#) together with dispatch lists of materials to the purchaser.

12.2 All drawings etc. mentioned in 12.1 above will in every respect be the property of purchaser who shall have the right to use and reuse them for any purpose what so ever without any obligation to Vendor.

12.3 Papers used for drawings and prints shall be suitable for the purpose, according to TAPPI T1 0404-36-87, Paper Grade Classification, or, as approved by the Company.

13. PACKAGING (Add.)

13.1 General requirements for packaging are covered in Appendix C of this Standard.

14. SHIPMENT (Add.)

14.1 Refer to Appendix D for general requirements for shipment.

15. GUARANTEE (Add.)

15.1 Appendix E of this Standard covers general requirements for guarantee.

APPENDICES**APPENDIX A
QUOTATION**

- A.1** The following information shall be submitted in the quotation:
- A.1.1** Price
- A.1.2** Estimated total shipping weight of materials for each tank with accessories.
- A.1.3** Delivery time of the materials
- A.1.4** Steel grades offered
- A.1.5** Plate thicknesses
- A.1.6** Any deviations or exclusions from the stipulations referred to in this specification. If no deviations or exclusions are mentioned in the quotation, it will be deemed to be fully in compliance with said stipulations.
Vendor is free to offer as an alternative, before the purchase order is placed, deviations from the required standards, if these result in a reduction in costs.
- A.1.7** The names of subcontractors, if any for the fabrication or any part thereof. Such subcontractors shall be subject to acceptance by purchaser.
- A.2** Any purchase order will be subject to all terms, conditions, etc. forming part of the inquiry and any agreed amendments to it.

APPENDIX B**SECRECY**

Vendor shall not disclose or issue to third parties without the written consent of purchaser any documents, etc. placed at his disposal by purchaser or any documents prepared by himself in connection with inquiries and purchase orders for purposes other than the preparation of a quotation or carrying out such purchase orders.

**APPENDIX C
PACKAGING**

- C.1** When considering the following instructions, due regards shall be paid to handling facilities in transit and at the destination, and also to any special packaging instruction given in the purchase order.
- C.2** Structural materials and plates shall be treated as follows:
- C.2.1** To prevent damage in transit all roof plates shall be bundled by welded clips as shown in Appendix C Fig.1 attached.
The maximum weight of a single bundle shall not exceed approximately 1.1/2 tons.
Bundling shall not take place until the paint is thoroughly dry.
- C.2.2** All shell and bottom plates shall be bundled as described under C.2.1 above, except that maximum weight of a single bundle shall not exceed approximately 2 tons.
- C.2.3** All structural members, such as roof framing, curb angles, wind girders, hand rails and stair treads, Shall be bundled and secured by bolting or tack welding. To prevent the nuts from loosening during transit, either the threads must be damaged or the nuts spot welded to the bolts. The weight of a single bundle shall not exceed approximately one ton.
- C.2.4** All gusset plates, cleats, etc. shall be securely bundled by bolting, each bundle weighing approximately ¼ ton.
- C.2.5** All small parts such as bolts, nuts, erection key plates, shim plates, wedges, etc. shall be bagged and packed separately, and shall be enclosed in stout wooden cases. The minimum thickness of timber used for the cases shall be 22 mm. The total weight of each case shall not exceed approximately ½ ton.
- C.3** Roof and shell manholes, nozzles, bottom sumps and clean outs, etc. may be shipped loose. Manhole and clean out cover shall be bolted on with gasket in position. Flange of nozzles, etc. Shall be adequately protected to prevent damage in transit.
Roof vents dip hatches and similar small fittings shall be packed complete with gasket, etc. in stout wooden case, and shall be securely fixed there to prevent damage in transit.
Cases shall be made of timber not less than 22 mm thick strongly battened, and banded with tensioned steel strapping. The weight of any case shall not exceed ½ ton
- C.4** All welding electrodes, rods, wires and fluxes shall be packed in such a manner as to keep them in first class condition during transport and storage.
Welding electrodes shall be supplied in containers which give adequate protection against damage and moisture in transit and in storage on site.
The type of packing to be employed shall be specified by the electrode manufacturer.

(to be continued)

APPENDIX C (Continued)
BUNDLING METHOD

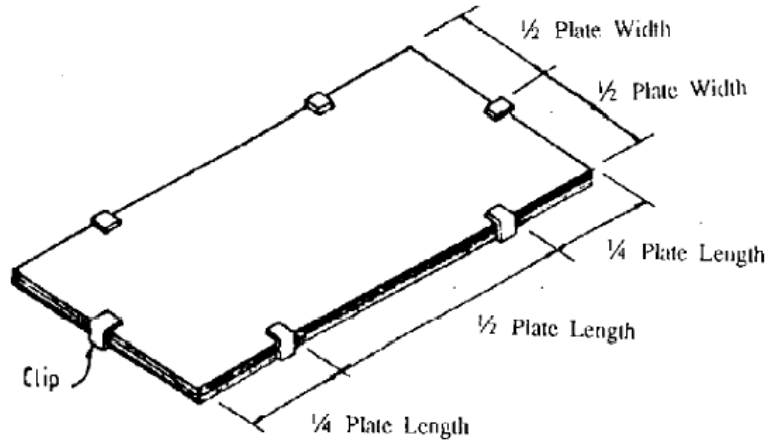

Note 1:

Use 6 numbers of clips for each bundle except where $\frac{1}{2}$ plate length exceeds 4 m in that case use three clips on each side which is 8 clips per bundle.

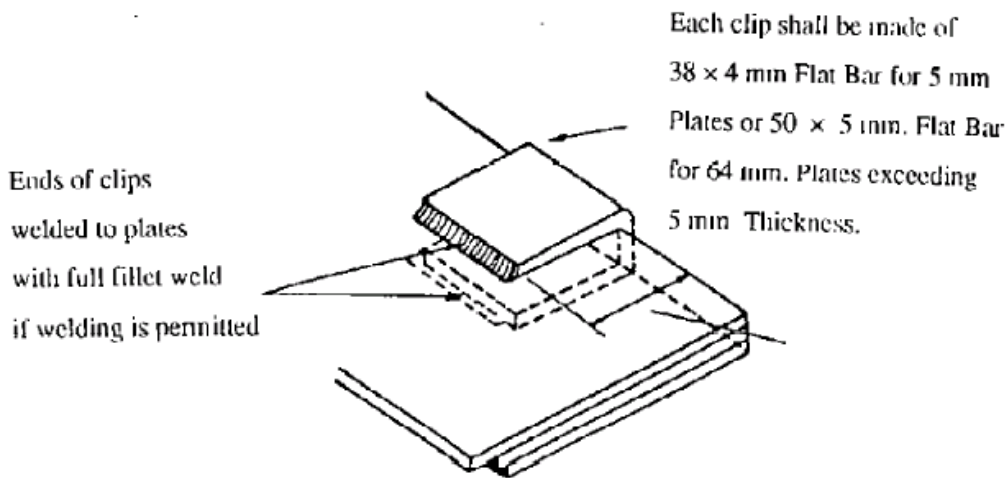

Note 2:

When welding is not permitted use other safe methods for bundling.

BUNDLING OF ROOF, SHELL AND BOTTOM PLATES

Fig. 1

**APPENDIX D
SHIPMENT**

- D.1** Plates and storage tank material shall be loaded in such a manner as to ensure delivery without damage.
- D.2** Shipping marks shall be provided as follows:
- D.2.1** Whenever possible, the shipping marks and any other desired particulars shall be stenciled on each bundle, case or package. Stenciled marks shall be at least 50 mm high. If stenciling cannot be applied, the information shall besuitably stamped on a metal label, securely attached to the package.
Stamped symbols shall be at least 13 mm high.
- D.2.2** If any confusion is likely to arise in reception, storing or distribution of the materials (e.g. in the case of purchase orders comprising materials for more than one tank), all parts shall have painted on them a further distinctive mark in addition to any erection or shipping marks. Such additional marking shall consist of a colored band or other mark as agreed with purchaser.
- D.2.3** All identification marks shall be applied on at least two sides of each package.
- D.3** Each package, case and bundle shall be accompanied with a packing list.

**APPENDIX E
GUARANTEE**

- E.1** Vendor shall guarantee that the materials delivered to be incorporated into storage tank(s) are in accordance with the purchase order and will be free from any defects in design, workmanship and material and that they will give proper service under the operating and design conditions as specified, for a period of 18 months, reckoned from the day on which the tanks are delivered.
- E.2** The period of 18 months specified above shall be extended by any period(s) during which the tanks after delivery are out of action as a result of any defect covered by this guarantee.
- E.3** In the event of defects covered by this guarantee purchaser shall notify vendor as soon as possible and vendor shall without delay remedy or repair free of charge (cost of labor and transportation not excluded) the tank(s) having such defects, or authorize purchaser to do so. In the latter event vendor shall reimburse to purchaser the actual out of pocket costs, excluding overheads and similar administrative costs.
- E.4** Remedying and repairing may be effected by purchaser without prior approval by vendor in cases where it would be unreasonable to demand that prior approval be obtained. In such cases vendor and purchaser shall agree which party shall bear the costs and expenses thereof or in what proportion these costs and expenses shall be divided between them. This guarantee shall remain in effect, provided the remedying and repairing do not result in any detriment to the tank (s).
- E.5** In no event will this guarantee cover defect due to normal wear and tear, disregard by purchaser or his consignee of operating instructions, excessive over loading by purchaser or his consignee or unsuitable operating conditions.

**APPENDIX F
STORAGE TANK DATA SHEET**

GENERAL INFORMATION

Date.....
By.....
File No.....
Page 1 of 6

General Information (To Be Completed by Purchaser)

- 1) **Purchaser/agent**
Address.....
City State Zip Phone.....
- 2) **User**
- 3) **Erection site** Name of Plant
Location
- 4) **Tank no**..... Nominal capacity barrels
Net working capacity barrels
- 5) **Pumping rates:** In barrels/hour
Out barrels/hour
- 6) **Maximum operating temperature** Deg.C
- 7) **Product stored**
Design specific gravity at Deg.C
Design metal temperature Deg.C
Vapor pressure kPa
- 8) **Corrosion allowance:**
Shell mm Roofmm
Bottom mm Structural mm
- 9) **Shell design:** Basic Standard 650 -88 Appendix A Appendix F
Design pressure kPa
- 10) **Roof Design:** Basic Standard 650-88
Appendix C (external Floating)
Appendix H (internal Floating)
Frangible roof joint? Yes No

Note:

All figures, paragraphs, tables and appendices referred to in Appendix F are related to API-650-1988

(to be continued)

APPENDIX F (Continued)

Date.....
By.....
File No.....
Page 2 of 6

11) Roof Loads: Uniform live kPa
Special (provide sketch) kPa

12) Earthquake design? Yes No (Appendix E)
Roof tie rods (3.10.4.5)? Yes No
Seismic zone (Figure E-1)
Essential facilities factor
Zone coefficient (Table E-1)
Site amplification factor (Table E-2)

13) Wind load: Velocity km/hr
Provide intermediate windgirder (3.9.7)?
Yes No

14) Environmental effects:
Maximum rainfall mm/hr
Total snow accumulationmm

15) Size restrictions: Maximum diameter meter
Maximum height meter

16) Foundation type: Earth Concrete ringwall
Other

Remarks:

.....
.
.....
.
.....
.
.....
.
.....
.
.....
.

Note:

All figures, paragraphs, tables and appendices referred to in Appendix F are related to API-650-1988.

(to be continued)

APPENDIX F (Continued)
STORAGE TANK DATA SHEET

CONSTRUCTION DETAILS

Date.....
By.....
File No.....
Page 3 of 6

Construction Details (To Be Completed by Manufacturer and/or Purchaser)

1) Manufacturer

Address.....
City State ZIP Phone.....
Serial No

2) Material specifications: Shell

Roof
Bottom
Structurals

3) No. of shell courses

4) Plate widths and thicknesses (including corrosion allowance):

1 4 7
2 5 8
3 6 9

5) Tank bottom: Plate thicknessmm Lap Butt Seams
Slopemm per meter To From Center

6) Minimum width and thickness of bottom annular plates (3.5)

7) Roof to shell detail (Figure F-1)

8) Intermediate Windgirder? Yes No
Top windgirder for use as walkway? Yes No

9) Roof type: Supported Self supported floating
Slope or radiusmm

10) Roof plate: Thicknessmm Lap Butt Joint

Note:
All figures, paragraphs, tables and appendices referred to in Appendix F are related to API-650-1988

(to be continued)

**APPENDIX F (Continued)
STORAGE TANK DATA SHEET**

CONSTRUCTION DETAILS

Date.....

By.....

File No.....

Page 4 of 6

11) Paint:

Shell-	Exterior?	Yes	No	Interior?	Yes	No
	Surface preparation					
Bottom-	Underside?	Yes	No	Interior?	Yes	No
	Surface preparation					
Structural Steel-	Exterior?				Yes	No
	Interior?				Yes	No
	Specification					

12) Tank Bottom coating: Interior? Yes No
 Material
 Application specification

13) Inspection by: Shop Field

14) Weld examination: Radiograph
 Supplementary liquid penetrant or ultrasonic

15) Films..... Property of

16) Leak testing: Bottom Roof
 Shell

17) Mill test reports: Required? Yes No
 Plate Structural shapes

18) Purchaser's reference drawing

19) Tank size : Diametermeter Heightmeter

20) Date of Standard 650 edition/revision

Remarks:

 .

 .

Note:
 All figures, paragraphs, tables and appendices referred to in Appendix F are related to API-650-1988.

(to be continued)

APPENDIX F (Continued)
STORAGE TANK DATA
APPURTENANCES

Date.....

By.....

File No.....

Page 6 of 6

11) Roof nozzles, including venting connection

(see Figures 3-4 and 3-15 and Tables 3-16 and 3-17)

Mark	Size	Flanged	Threaded	Reinforcement	Orientation N=0	Distance From Center	Service

Notes:

- 1) Sketches and/or separate sheets may be attached to cover special requirements.
- 2) All figures, paragraphs, tables and appendixes referred to in Appendix F are related to API-650-1988.