

MATERIAL STANDARD

FOR

WORKSHOP AND WALL SUPPORTED JIB CRANES

AND

CHAIN HOISTS

ORIGINAL EDITION

JULY 1997

This standard specification is reviewed and updated by the relevant technical committee on Sep. 2003. The approved modifications are included in the present issue of IPS.

CONTENTS :	PAGE No.
0. INTRODUCTION	2
CHAPTER 16-0	3
Section 16.0.1 SCOPE	3
16.0.1.1 Alternative designs	3
16.0.1.2 Conflicting requirements	3
16.0.2 DEFINITIONS	4
16.1.2.2 Electrical design (electric-powered hoists only) (Mod.)	4
16.1.2.3 Controls (electric or air-powered hoists only) (Mod.)	5
16.1.2.18 Overload limiting device (Add.)	5
16.1.2.19 Trolley (Add.)	5
16.4 PREPARATION FOR SHIPMENT (Add.)	6
16.5 GUARANTEE AND WARRANTY (Add.)	6
16.6 VENDOR'S DATA	6
 APPENDICES:	
APPENDIX A TYPICAL HAND CHAIN MANUALLY OPERATED HOIST DATA SHEET	9
APPENDIX B TYPICAL ELECTRIC AND AIR OPERATED HOIST DATA SHEET	8

0. INTRODUCTION

This Standard gives the amendment and supplement to ASME B30.16A-2001 overhead hoists (underhung). It shall be used in conjunction with data sheets. For ease of reference, the clause (or paragraph) numbering of ANSI B 30.16 has been used throughout of this Standard. Clauses in ANSI B 30.16 not mentioned remain unaltered. For the purpose of this Specification the following definitions shall hold:

Sub. The ANSI Std., clause is deleted and replaced by a new clause.

Del. The ANSI Std., clause is deleted without any replacement.

Add. A new clause with a new number is added.

Mod. Part of the ANSI Std., clause is modified and/or a new statement or comment is added to that clause.

CHAPTER 16-0

Section 16.0.1 SCOPE

This Standard covers general requirements for wall supported jib crane (Fig. 8), hand chain manually operated chain hoists, electric and/or air chain or rope hoists, for use in refinery services, chemical plants, gas plants, petrochemical plants and where applicable in exploration, production and new ventures.

Compliance by the hoist manufacturer with the provisions of this standard does not relieve him of responsibility of furnishing hoist and accessories of proper design, mechanically suited to meet guarantees at specified service conditions.

No deviations or exceptions from this standard shall be permitted without the written prior approval of the purchaser.

Intended deviations shall be separately listed by the vendor and supported by reasons there of for purchaser's consideration. (Mod.)

Note:

This standard specification is reviewed and updated by the relevant technical committee on Sep. 2003. The approved modifications by T.C. were sent to IPS users as amendment No. 1 by circular No 198 on Sep. 2003. These modifications are included in the present issue of IPS.

16.0.1.1 Alternative designs

Equivalent SI unit systems, dimensions and ratings shall be used, unless otherwise specified. (Add.)

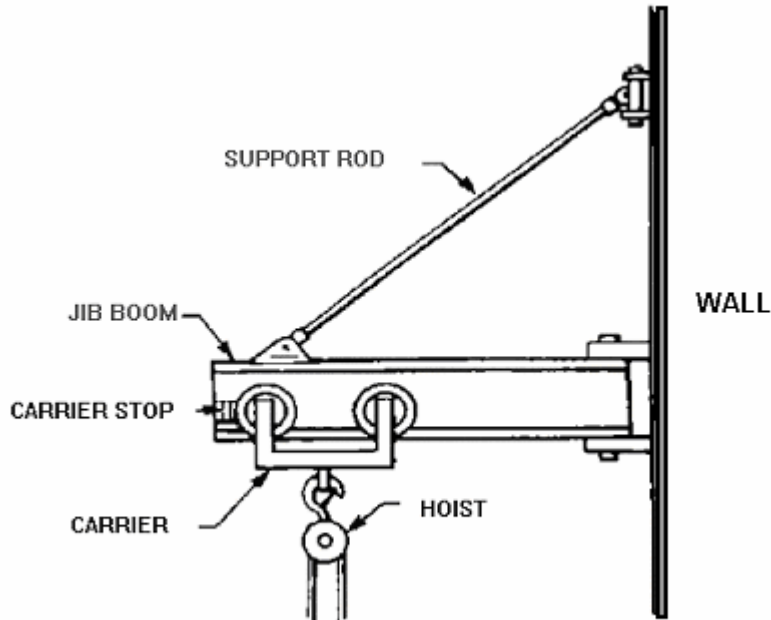

WALL SUPPORTED JIB CRANE

Fig. 8

16.0.1.2 Conflicting requirements

In the case of conflict between documents relating to the inquiry or order, the following priority of

documents shall apply:

- **First Priority:** Purchase order and variations there to
- **Second Priority:** Data sheets and drawings
- **Third Priority:** This Standard specification

All conflicting requirements shall be referred to the purchaser in writing. The purchaser will issue confirmation document if needed for clarification. (Add.)

16.0.2 DEFINITIONS

Beam

An overhead standard structural shape or specially fabricated shape on which a trolley operates. (Add.)

Reach

Distance which trolley can travel on beam. (Add.)

Reeving

(See Fig. 9.) (Mod.)

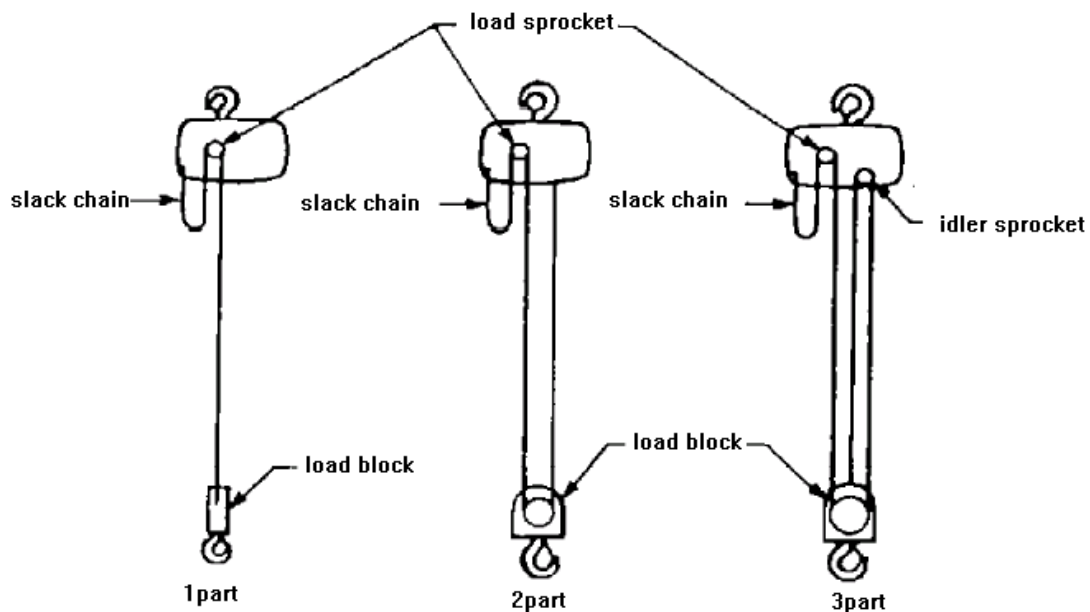

REEVING

Fig. 9

16.1.2.2 Electrical design (electric-powered hoists only) (Mod.)

e) Motors shall be reversible, with torque characteristics suitable for hoist or trolley service and capable of operation at rated loads and speeds in accordance with class of service specified.

f) Temperature rise of motors shall be in accordance with the latest NEMA standards for the class of insulation and enclosure used. The hoist manufacturer will assume 45°C ambient

temperature unless otherwise specified by the purchaser.

g) All motors at rated frequency shall be capable of operation at $\pm 10\%$ of rated motor voltage, but not necessarily at rated voltage performance.

h) Typical rated motor voltage shall be in accordance with Table 3.

i) For nominal system voltages other than shown in Table 3, the rated motor voltage should not be less than 95% and shall not exceed the nominal system voltage.

TABLE 3 - TYPICAL RATED MOTOR VOLTAGES

POWER SUPPLY	NOMINAL SYSTEM	RATED MOTOR VOLTAGES	PERMISSIBLE MOTOR OPERATING RANGE
AC Single phase, 50 Hz	230	220	198 to 242
AC Polyphase 50 Hz	400	380	342 to 418

16.1.2.3 Controls (electric or air-powered hoists only) (Mod.)

e) The pendant control station shall be clearly marked to indicate the function of each actuator.

f) Unless otherwise specified, and as applicable, the order of control functions shall be, from top to bottom, HOIST, TROLLEY, and other functions.

g) STOP-START (OFF-ON, POWER OFF-POWER ON) control, if supplied, should be located at the top, above the hoist control function. The stop (OFF, POWER OFF) control shall be red.

h) Unless otherwise specified the standard pendant control shall have a cord length which will locate the pendant approximately 0.9 m to 1.2 m above the lower limit of lift.

i) Pull cord control, when furnished, shall consist of a self-centering, return-to-neutral, controller or master switch for the motion of hoist or trolley. Two nonconducting pull cords with suitable handles, clearly marked for direction, shall be provided for operation of each controller or master switch. Unless otherwise specified, the standard pull cord control shall have a cord length which will locate the control handles approximately 1.2 m to 1.5 m above the lower limit of lift.

16.1.2.18 Overload limiting device (Add.)

An overload limiting device, when furnished, shall be designed to permit operation of the hoist within its rated load and to limit the amount of overload that can be lifted by a properly maintained hoist, under normal operating conditions.

The overload limiting device may allow the lifting of an overload, but shall be designed to prevent the lifting of an overload that could cause damage to the hoist.

This does not imply that any overload is to be intentionally applied to the hoist.

The overload limiting device is an emergency device and shall not be used to measure the maximum load to be lifted, and shall not be used to sense the overload imposed by a constrained load.

16.1.2.19 Trolley (Add.)

When a trolley hoist is required or a trolley is required for use with a hoist, the type and size of support beam and minimum radius of beam, where applicable, shall be specified by the purchaser to insure that the trolley is suitable for operation on the beam.

16.4 PREPARATION FOR SHIPMENT (Add.)

16.4.1 Preparation for shipment shall be in accordance with Vendor's standards and as noted herein. The Vendor shall be solely responsible for the adequacy of the "preparation for shipment" provision employed with respect to materials and application, to provide materials to their destination in "ex-works" condition.

16.4.2 Vendor shall provide for the following minimum preparation for shipment and packing features for all equipment:

all equipment shall be packed, securely anchored (skid mounted when required) and weather protected for export overseas shipment. Separate, loose and spare parts shall be completely boxed.

16.4.3 Adequate protection shall be provided against mechanical damage and atmospheric corrosion in transit and for at least eighteen (18) months outdoor storage at jobsite prior to installation.

16.4.4 Exposed finish and machined surfaces, including bolting, shall be given a heavy coating of rust inhibiting compound.

16.4.5 Bearings and seal assemblies shall be fully protected from rusting, entry of moisture and dirt.

16.4.6 Impression stamped metal tags shall be wired to each item indicating Equipment Item No. and purchase order No. All pieces of equipment and spare parts shall be identified by item number and service, and marked on-both in-side and outside of each individual package or container.

16.4.7 Unless approved otherwise by Company, separate shipment of equipment and materials is not allowed.

16.5 GUARANTEE AND WARRANTY (Add.)

Vendor shall guarantee that the equipment supplied shall be of sound, high grade material, built in a workmanlike manner and perform as described in this specification and attachments. Any material proving defective within one (1) year after start of operation or twenty-four (24) months after shipment, whichever comes first shall be replaced free of charge, F.O.B. Vendor's plant.

16.6 VENDOR'S DATA (Add)

16.6.1 Vendor shall supply all drawings and data necessary to install the crane.

16.6.2 Vendor shall provide information covering the following:

- a) Lifting speed.
- b) Material specifications.
- c) Type and rating of prime mover.
- d) Specification and lengths for rope and/or chain supplied.
- e) List of all tools and accessories supplied with the crane, indicating those which are "special" tools.
- f) Any unusual maintenance or servicing procedure unique to the crane.

APPENDICES (ADD)

APPENDIX A
 TYPICAL HAND CHAIN MANUALLY OPERATED
 HOIST DATA SHEET

Job No. Rev.
 Item No. Data
 Inq. / P.O. No.
 Page of

For : Site :	Quantity of hoist required
HOIST	BEAM DATA (Trolley suspended hoist only)
Load capacityTons (.....kg) Rated capacity Tons (.....kg) Liftm Reachm Headroommm	Type and size of beam..... Width of running flangemm Minimum radius of beam curvesm
TYPE OF SUSPENSION:	ENVIRONMENTAL CONDITIONS:
b Hook b Clevis b Trolley	Location : b Indoor b Outdoor b Both
TROLLEY (separate)	Temperature : b Max. °C : b Min.°C
Quantity of trolleys required	Hazardous area : b Yes b No, If yes, specify
Rated capacity Tons (.....kg)	Class Div. Group
Type : b Plain b Hand chain operated	UNUSUAL CONDITIONS:
Hand chain dropm	Long exposure to weather : b Yes b No
TROLLEY (Integral)	Dust laden or moisture laden atmospheres, b Yes b No
Type: b Plain b Hand chain operated	If yes, Furnish complete information
Headroom (including hoist)mm
Hand chain dropm

**APPENDIX B
TYPICAL ELECTRIC AND AIR OPERATED
HOIST DATA SHEET**

Job No. Rev.
 Item No. Data
 Inq. / P.O. No.
 Page of

For : Site :	Quantity of hoist required
HOIST Load capacityTons (.....kg) Rated capacity Tons (.....kg) Liftm Reachm Headroommm Distance from operating floor to under side of beam or to point of support Hoisting speedm/min Type of control : b Single speed b Two speed b Other Control voltage b 24 b 115 b Other POWER SUPPLY: Voltage / Phase / Hertz / / Air: pressure barg Temperature°C Flowrate m ³ /hr	TYPE OF SUSPENSION: b Lug b Hook b Clevis b Plain trolley b Hand chain operated trolley b Motor operated trolley b Other..... TROLLEY Travel speed m/min b Trolley brake required Type of control: b Single speed b Two speed b Cushioned start b Other..... Type and size of beam..... Width of running flange mm Minimum radius of beam curves m CURRENT CONDUCTOR SYSTEM: b Flexible cable or b Festooned cable b Cable reel b Rigid conductor b Coil cord b Other Type of conductors
ENVIRONMENTAL CONDITIONS Location: b Indoor b Outdoor b Both Temperature b Max.°C b Min.°C Hazardous Location: b Yes b No, If yes specify Class Div. Group UNUSUAL CONDITIONS: Long exposure to weather : b Yes b No Corrosive fumes : b Yes b No Dust laden of moisture laden atmospheres, b Yes b No If yes, Furnish complete information	