

MATERIAL AND EQUIPMENT STANDARD**FOR****FORK LIFT TRUCK****ORIGINAL EDITION****DEC. 1997**

This standard specification is reviewed and updated by the relevant technical committee on June 2012. The approved modifications are included in the present issue of IPS.

FOREWORD

The Iranian Petroleum Standards (IPS) reflect the views of the Iranian Ministry of Petroleum and are intended for use in the oil and gas production facilities, oil refineries, chemical and petrochemical plants, gas handling and processing installations and other such facilities.

IPS is based on internationally acceptable standards and includes selections from the items stipulated in the referenced standards. They are also supplemented by additional requirements and/or modifications based on the experience acquired by the Iranian Petroleum Industry and the local market availability. The options which are not specified in the text of the standards are itemized in data sheet/s, so that, the user can select his appropriate preferences therein

The IPS standards are therefore expected to be sufficiently flexible so that the users can adapt these standards to their requirements. However, they may not cover every requirement of each project. For such cases, an addendum to IPS Standard shall be prepared by the user which elaborates the particular requirements of the user. This addendum together with the relevant IPS shall form the job specification for the specific project or work.

The IPS is reviewed and up-dated approximately every five years. Each standards are subject to amendment or withdrawal, if required, thus the latest edition of IPS shall be applicable

The users of IPS are therefore requested to send their views and comments, including any addendum prepared for particular cases to the following address. These comments and recommendations will be reviewed by the relevant technical committee and in case of approval will be incorporated in the next revision of the standard.

Standards and Research department

No.17, Street14, North kheradmand

Karimkhan Avenue, Tehran, Iran .

Postal Code- 1585886851

Tel: 021-88810459-60 & 021-66153055

Fax: 021-88810462

Email: Standards@nioc.ir

GENERAL DEFINITIONS:

Throughout this Standard the following definitions shall apply.

COMPANY:

Refers to one of the related and/or affiliated companies of the Iranian Ministry of Petroleum such as National Iranian Oil Company, National Iranian Gas Company, National Petrochemical Company and National Iranian Oil Refinery And Distribution Company.

PURCHASER:

Means the "Company" where this standard is a part of direct purchaser order by the "Company", and the "Contractor" where this Standard is a part of contract documents.

VENDOR AND SUPPLIER:

Refers to firm or person who will supply and/or fabricate the equipment or material.

CONTRACTOR:

Refers to the persons, firm or company whose tender has been accepted by the company.

EXECUTOR:

Executor is the party which carries out all or part of construction and/or commissioning for the project.

INSPECTOR:

The Inspector referred to in this Standard is a person/persons or a body appointed in writing by the company for the inspection of fabrication and installation work.

SHALL:

Is used where a provision is mandatory.

SHOULD:

Is used where a provision is advisory only.

WILL:

Is normally used in connection with the action by the "Company" rather than by a contractor, supplier or vendor.

MAY:

Is used where a provision is completely discretionary.

CONTENTS:**PAGE No.**

0. INTRODUCTION	4
1. SCOPE	5
3. INTERPRETATION	5
3.4 Units	5
3.5 Classification by Functional Type	5
3.6 Classification by Power-Source Type	5
7. DESIGN AND CONSTRUCTION STANDARDS	5
7.4 Rated Capacity	5
7.6 General Stability Criteria-Tilting Platform Tests	6
7.17 Parking Brake System Performance for Trucks up to and Including 50000 kg Capacity	8
7.18 Travel Direction Control(s) Marking	8
7.21 Travel Control-Internal Combustion-Powered Industrial Trucks, Sit-Down Rider	9
7.27 Forks	9
7.44 Tilting Angles of Mast or Fork	10
7.45 Strength of Lifting Chain	10

APPENDICES:

APPENDIX A DIMENSIONS	11
APPENDIX B Data Sheet	13
Part IV GLOSSARY OF COMMONLY USED WORDS AND PHRASES	14
Part V REFERENCES	16

0. INTRODUCTION

This Standard gives the amendment and supplement to ASME/ITSDF B56.1-2009, "Safety Standard for Low Lift and High Lift Trucks". It shall be used in conjunction with data sheets. For ease of reference, the clause (or paragraph) numbering of ANSI B 56.1 has been used throughout this Standard. Clauses in ANSI/ITSDF B56.1 not mentioned remain unaltered.

For the purpose of this Standard the following definitions shall hold:

- Sub.:** The ANSI Std., clause is deleted and replaced by a new clause.
- Del.:** The ANSI Std., clause is deleted without any replacement.
- Add.:** A new clause with a new number is added.
- Mod.:** Part of the ANSI Std., clause is modified and/or a new statement or comment is added to that clause.

1. SCOPE

This Standard contains the minimum requirements relating to the elements of design, construction, safety and testing of low lift and high lift powered industrial lift trucks controlled by a riding or walking operator for use in refinery services, chemical plants, gas plants, petrochemical plants and where applicable in exploration, production and new ventures.

Compliance by the truck manufacturer with the provisions of this Standard does not relieve him of responsibility of furnishing lift truck and accessories of proper design, mechanically suited to meet guarantees at specified service conditions.

No deviations or exceptions from this Standard shall be permitted without the written prior approval of the Purchaser.

Intended deviations shall be separately listed by the Vendor and supported by reasons thereof for purchaser's consideration. **(Mod.)**

Note:

This standard specification is reviewed and updated by the relevant technical committee on June 2012. The approved modifications by T.C. were sent to IPS users as amendment No. 1 by circular No 355 on June 2012. These modifications are included in the present issue of IPS.

3. INTERPRETATION

3.4 Units (Mod.)

This Standard is based on International System of Units (SI), as per [IPS-E-GN-100](#) except where otherwise specified. **(Mod.)**

3.5 Classification by Functional Type (Add.)

The classification by the functional type shall be as given in the following:

- 1) Counterbalanced fork lift truck.
- 2) Reach fork lift truck.
- 3) Straddle fork lift truck.
- 4) Side fork lift truck.
- 5) Order picking truck.

3.6 Classification by Power-Source Type (Add.)

3.6.1 Internal combustion engine type (Add.)

The internal combustion types shall be as follows:

- 1) Diesel type symbol FD
 - 1.1) Bio-diesel Engine
- 2) Liquefied petroleum gas type symbol FL

3.6.2 Storage battery type (Add.)

The storage battery type shall be as follows:

- Storage battery type symbol FB

7. DESIGN AND CONSTRUCTION STANDARDS

7.4 Rated Capacity

7.4.6 The standard lifting height specified for determining the rated capacity shall be 3000 mm. **(Add.)**

7.4.7 The maximum lifting heights shall generally be as given in Table 17. (Add.)

TABLE 17- MAXIMUM LIFTING HEIGHTS (mm)

Maximum height (mm)	2500, 2700, 3000, 3300, 3500, 3700, 4000, 4300, 4500, 5000, 5500, 6000
---------------------	--

7.6 General Stability Criteria-Tilting Platform Tests

7.6.8 Additional tests (Add.)

7.6.8.1 Test conditions

In the tests mentioned in the following, quantities of fuel, cooling water, lubricating oil and working fluid, and the pneumatic pressure of tires shall be those specified values as determined for that fork lift truck concerned. (Add.)

7.6.8.2 Stationary test

7.6.8.2.1 The measurements of principal dimensions shall be carried out on the following respective items:

- 1) Overall length.
- 2) Overall width.
- 3) Overall height.
- 4) Wheel base.
- 5) Track tread (front wheel and rear wheel).
- 6) Front over hang.
- 7) Ground clearance.
- 8) Fork (length, width and thickness).
- 9) Maximum lift lifting height.
- 10) Overall extended height.
- 11) Free lift.
- 12) Tilting angle of mast or fork.

Remark:

The items for measurements of dimensions shall be those specified in the counterbalanced fork lift trucks, and those for other fork lift trucks than the counterbalanced fork lift trucks shall be in accordance with these, as appropriate. (Add.)

7.6.8.2.2 Masses at the standard unloaded condition and standard loaded condition, and front wheel and rear wheel loads shall be measured. (Add.)

7.6.8.3 Travelling Test

The travelling test, unless particularly specified, shall be carried out on a flat and dry paved road surface under the standard unloaded condition and the standard loaded condition:

1) The maximum speed test shall be conducted in both the advancing and back and forth directions at a measuring interval of 50 m and at an arbitrary entrance length, and their mean value shall be taken.

Furthermore, the required time for travel to the point of 25 m at the center of 50 m interval shall be measured to ascertain that the maximum speed has been attained.

2) The travelling resistance tests shall consist of the two methods as given in the following. However, (a) should preferentially be selected, and (b), selected as required:

- a) A method in which the coasting times are measured.
- b) A method in which the time required until stopping is measured.

Carry out measurements on the advancing and back-and-forth directions and employ their mean value. Let a truck travel at the initial speed of 15 ±1 km/h (for that of which maximum speed is under 15 km/h, take this maximum speed.) until it

reaches the starting point of the coasting, release the clutch at the starting point of the coasting interval, set the speed change gear to the neutral position to start coasting, and measure the times; in the case of (b), measure the distance until it stops.

The measurement of the initial speed shall be obtained by measuring the travelling time of a 20 m interval before the coasting begins.

3) The minimum outside turning radius test shall be carried out, at the time of right and left turnings in an advancing direction, t_0 measure the turning radius r_0 of the outermost part of the body, at the maximum steering angle and the minimum speed. In this case, the truck shall be under the standard unloaded condition (see Fig. 23).

Furthermore, the turning radius r_0 and r_s of the center of the outermost wheel and the innermost part of the body may also be measured.

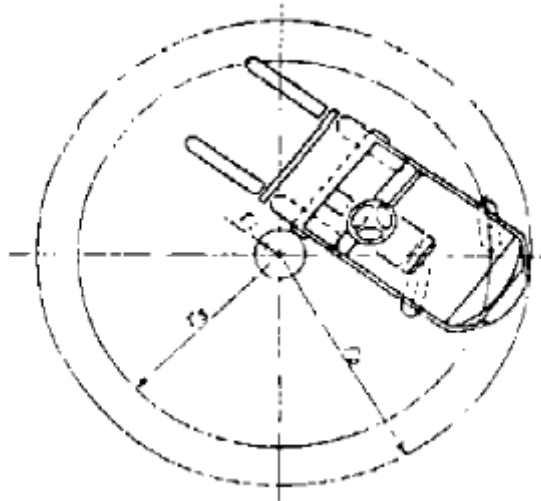

OUTSIDE TURNING RADIUS TEST

Fig. 23

4) The traction test shall be carried out at the advancing lowest speed step with inserting a tractive force meter between the truck to be drawn which is capable of controlling the tractive force to be drawn smoothly and the test truck. In the testing, the speed and the tractive force shall be measured at the time when the load of the truck to be drawn has been increased gradually. **(Add.)**

7.6.8.4 Material Handling Test

The material handling test, unless particularly specified, shall be carried out with the masts upright in the case where unloaded and the permissible capacity at rated load center has been loaded on the rated load center. In this case, the oil temperature of the working fluid shall be at about 40 to 50°C.

1) The lifting and lowering speed shall be obtained by measuring the time required for a fork lift truck which passes through a defined interval in which the lowering and lifting speed becomes stable.

2) The lowering amount and the change in tilting angle, at 15 min. after the prime mover has stopped, shall be measured, with placing the fork at the highest position and with closing the change over valve. In this case, the loads shall be in the state under unloaded condition and loaded condition of the permissible capacity at rated load at the standard load centre. **(Add.)**

7.17 Parking Brake System Performance for Trucks up to and Including 50000 kg Capacity

7.17.3 The parking brake shall actuate when it is pulled to the operator side, in the case of a manual type. In addition, in the case of a treadle type, it shall be actuated by depressing the pedal, and when the brake is to be released, it shall be operated by other means than the treading. **(Mod.)**

7.18 Travel Direction Control(s) Marking

7.18.1 The forward direction of the fork lift truck shall be that direction of an operator. Those arrow mark directions given in Figs. 24 and 25 are the forward directions. **(Add.)**

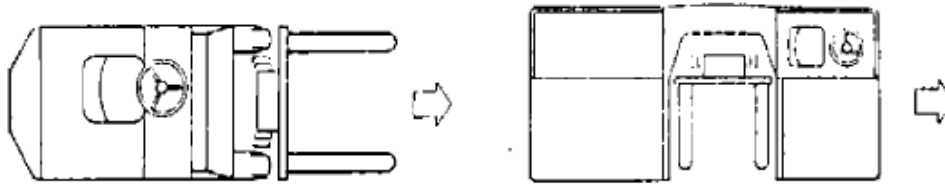

(a) Counterbalanced Fork Lift Truck

(b) Side Fork Lift Truck

PEDESTRIAN CONTROLLED TRUCK
Fig. 24

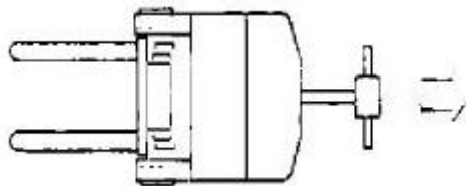

Informative reference Fig. 24 PEDESTRIAN CONTROLLED TRUCK

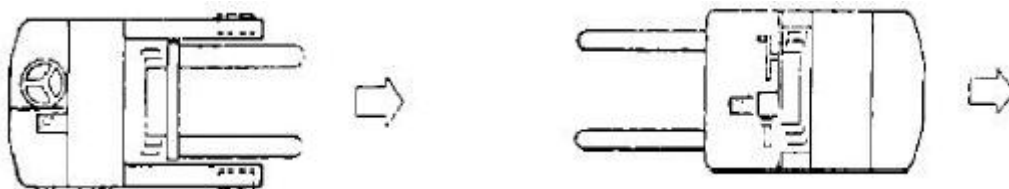

(a) Reach Fork Lift Truck and Straddle Fork lift Truck

(b) Order Picking Truck

FORK LIFT TRUCKS OPERATED BY STANDING OPERATOR
Fig. 25

Informative Reference: Fork Lift Truck operated by walking operator the mounting side of the steering device is defined as forward direction .The arrow mark direction given in Informative Reference Fig. 24 is the forward direction.

7.21 Travel Control-Internal Combustion-Powered Industrial Trucks, Sit-Down Rider

7.21.12 Gear change lever **(Add.)**

7.21.12.1 Operating mechanism

It should preferably be provided with a device which actuates to alarm automatically when the forward and backward gear change lever has been operated to the backward. **(Add.)**

7.21.12.2 Marking for discrimination

On the gear change lever or its vicinity, a durable marking shall be attached so that an operator can discriminate the operating positions of forward and backward and transmission-steps respectively at his seat. **(Add.)**

7.27 Forks

7.27.3 Strength of fork

The safety factor of the static strength of the fork shall be not less than 3. **(Mod.)**

Note:

The safety factor shall be that value obtained by dividing the yield point of the material used for a fork by the stress when the maximum load is applied to the load center of the fork.

7.27.5 The lengths and the maximum thickness of the forks shall generally be as given in the Table-18, according to the types of the permissible capacities at rated load center. **(Add.)**

TABLE 18

Permissible capacity at rated load center t		0.5	1	1.5	2	2.5	3	3.5	5	10	13.6
Maximum thickness of fork mm		30	40	40	50	55	60	65	80	90	**
	770	✓	✓								
	(850)*	✓	✓	✓							
	920	✓	✓	✓	✓	✓					
	1070	✓	✓	✓	✓	✓	✓	✓			
	1220		✓	✓	✓	✓	✓	✓	✓	✓	✓
Length of fork mm	1370		✓	✓	✓	✓	✓	✓	✓	✓	✓
	1520			✓	✓	✓	✓	✓	✓	✓	✓
	1670				✓	✓	✓	✓	✓	✓	✓
	1820						✓	✓	✓	✓	✓
	1970							✓	✓	✓	✓
	2120							✓	✓	✓	✓
	2270								✓	✓	✓
	2420								✓	✓	✓

* The numerical values in the parentheses may be used as required.

** To be calculated by manufacturer and reviewed by purchaser.

7.44 Tilting Angles of Mast or Fork

(Add.)

The tilting angles of the mast or fork, under dismounted condition of attachments, shall generally be as given in Table 19. **(Add.)**

TABLE 19- TILTING ANGLES OF MAST OR FORK

Tilting Angles of Mast or Fork	CLASSIFICATION		FORWARD TILTING ANGLE	BACKWARD TILTING ANGLE
	Counterbalanced fork lift truck	Pneumatic tire	6	12
	Solid tire	5	10	
Reach and straddle fork lift truck		3	5	
Side fork lift truck	Pneumatic tire	5	5	
	Solid tire	3	5	
Order picking truck		0	0	

Note:

Where the maximum lifting exceeds 3500 mm, the tilting angles of the mast or the fork shall be decreased.

7.45 Strength of Lifting Chain

(Add.)

The safety factor of the static strength of the chain used for the lifting mechanism shall be not less than 5. **(Add.)**

Note:

The safety factor shall be that value obtained by dividing the breaking load of a chain by the load being applied to the chain at the time when loaded with the permissible capacity at rated load center.

APPENDICES

APPENDIX A (Add.)
DIMENSIONS

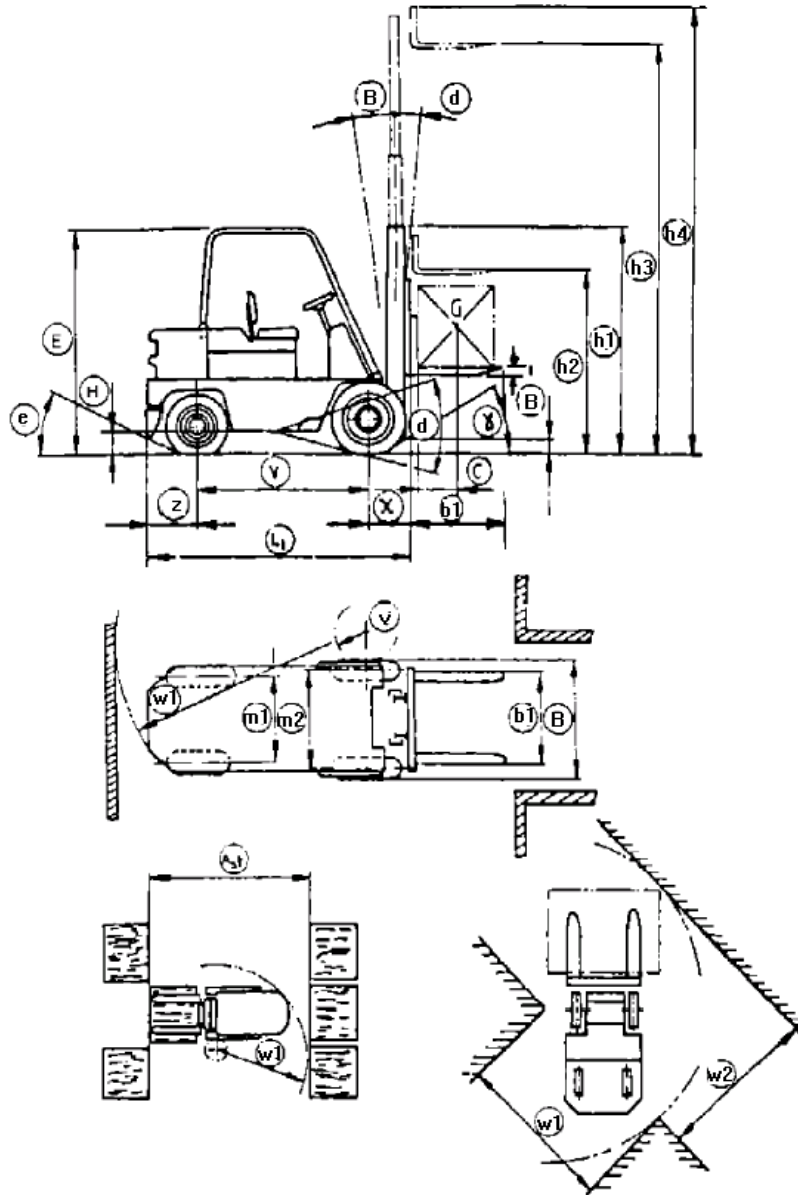

Fig. A.1

TRUCK DATA AND DIMENSION

h_4	Overall maximum height
h_3	Maximum lift height
h_1	Height mast closed
h_2	Free lift height
D	Ground clearance under mast
H	Ground clearance at centre of wheel-base
E	Height over cab or of overhead guard
B	Width
b_1	Fork length including fork heel
b_2	Outside spread of fork arms
m_2	Track, front
m_1	Track, rear
C	Load centre distance
X	Overhang, front
Y	Wheel-base
Z	Overhang, rear
L_1	Length without fork arms
δ	Approach angle
d	Ramp angle
e	Departure angle
α	Forward tilt
β	Backward tilt
ν	Minimum inside turning radius
W_1	Minimum outside turning radius
W_2	Width of theoretical minimum intersecting aisle
A_{st}	Width of theoretical minimum aisle for right-angle stacking (for given pallet)

APPENDIX B (Add.)

DATA SHEET

FORK LIFT TRUCK
DATA SHEET

JOB No. ITEM No.
PURCH. ORDER No. DATE
REQUISITION No.
INQUIRY No.

SITE _____		SERIAL NO. _____		
SERVICE _____		NO. REQUIRED _____		
MANUFACTURER _____ MODEL _____		DRIVER _____		
CHARACTERISTICS	USEFUL LOAD	CAPACITY (Duty)	kgf	
	LOAD CENTRE	DISTANCE	mm	
	POWER UNIT	ELECTRIC (BATTERY), DIESEL, GAS ENGINE		
	STEERING SYSTEM	POSITION OF DRIVER		
	WHEELS (X-DRIVE)	NUMBER, FRONT/ REAR		
DIMENSIONS	LIFT	LIFT HEIGHT Max.	mm	
	TILT	NORMAL FREE LIFT	mm	
		OF MAST, FORWARD / BACKWARD	degree	
	OVERALL DIMENSIONS	LENGTH WITHOUT FORK ARMS	mm	
		WIDTH	mm	
		HEIGHT, MAST CLOSED	mm	
		OVERALL MAXIMUM HEIGHT	mm	
	FORK DIMENSIONS	HEIGHT OVER CAB OR OF OVERHEAD GUARD	mm	
		THICKNESS	mm	
		FORK LENGTH INCL. FORK HEEL	mm	
TURNING RADIUS	OUTER	mm		
OVERHANG	FRONT	mm		
AISLE WIDTH	STACKING AISLE WIDTH	mm		
PERFORMANCE	STABILITY			
	SPEEDS	TRAVEL, LADEN/ UNLADEN	km/h	
		LIFTING, LADEN/ UNLADEN	cm/s	
		LOWERING, LADEN/ UNLADEN	cm/s	
GRADIENT PERFORMANCE	LADEN	%		
Weight	DEAD MASS	BATTERY INCL.	kg	
	AXLE WEIGHT	LADEN, FRONT/ REAR	kgf	
		UNLADEN, FRONT/ REAR	kgf	
CHASSIS	TIRES	SOLID RUBBER, PNEUMATIC. FRONT/ REAR		
		NO. FRONT/ REAR		
		DIMENSIONS	FRONT REAR	
	WHEELBASE	CENTRE OF TIRE, FRONT/ REAR		
	GROUND CLEARANCE	WITH RATED LOAD	AT LOWEST POINT	mm
			AT WHEELBASE CENTER	mm
BRAKES	SERVICE, PARKING	HYDRAULIC MECHANICAL		
ENGINE	SPECIFICATION	MANUFACTURER, TYPE		
		CYLINDER/CYCLE /		
		Max. POWER	kw (ps) @ rpm	
		Max. TORQUE	N.M (kg.m) @ rpm	
	COOLING SYSTEM	EMISSION CONTROL TYPE		
	STORAGE BATTERY	WATER COOLED, AIR COOLED		
		BATTERY TYPE		
No. of BATTERY	 No.		
BATTERY Vamp/hr			
TRANSMISSION	TRANSMISSION TYPE			
	GEAR CHANGE TYPE			
	No. of SPEEDS, FORWARD/REVERSE/.....		
	WORKING PRESSURE for ATTACHMENTS bar		
	OIL FLOW for ATTACHMENTS bar		
REMARKS: _____				

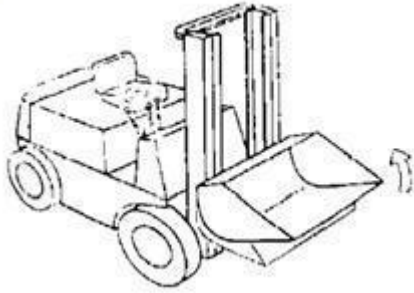
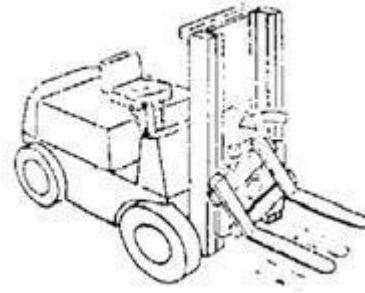
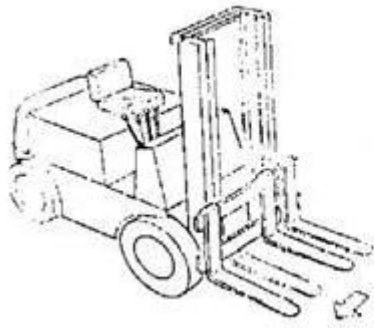
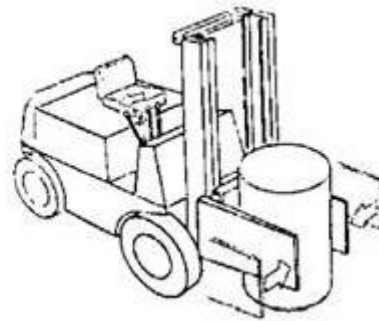
Part IV**GLOSSARY OF COMMONLY USED WORDS AND PHRASES (Mod.)****HINGED FORK LIFT AND BUCKET****Fig. 26****ROTATING FORK****Fig. 27****SIDE SHIFTER****Fig. 28****LOAD CLAMP****Fig. 29****(to be continued)**

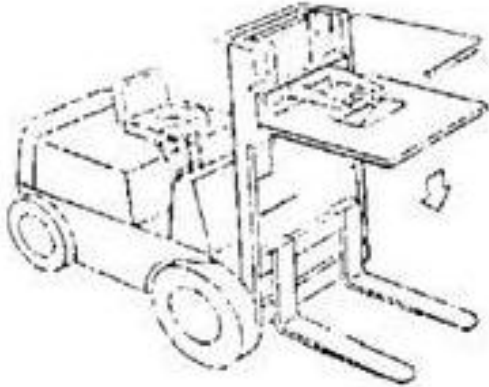
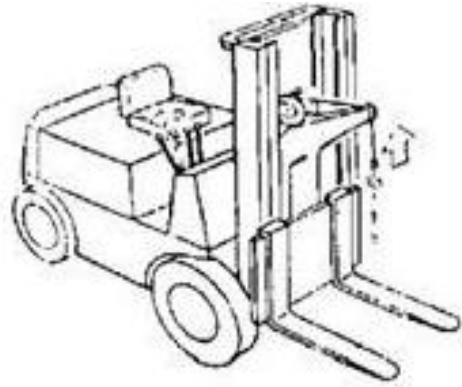
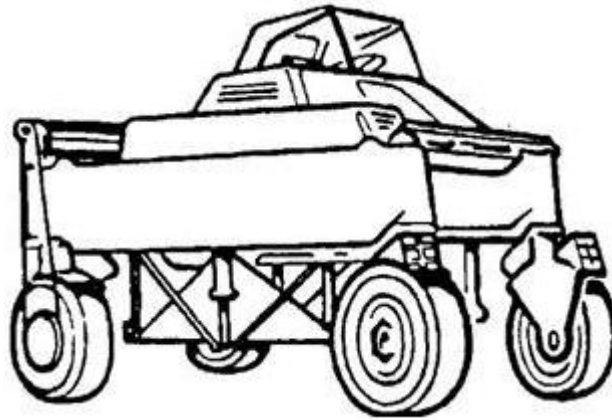
Part IV (continued)**LOAD STABILIZER****Fig. 30****WINCH****Fig. 31****NON-STACKING LOW-LIFT STRADDLE CARRIER****Fig. 32**

Part V
REFERENCES

Throughout this Standard the following dated and undated standards/codes are referred to. These referenced documents shall, to the extent specified herein, form a part of this standard. For dated references, the edition cited applies. The applicability of changes in dated references that occur after the cited date shall be mutually agreed upon by the Company and the Vendor. For undated references, the latest edition of the referenced documents (including any supplements and amendments) applies.

IPS (IRANIAN PETROLEUM STANDARDS)

[IPS-E-GN-100](#) "Engineering Standard for Units"

(Mod.)