

"5" BAR DETAIL

"4" BAR DETAIL

"3" BAR DETAIL

"2" BAR DETAIL

"1" BAR DETAIL

SEE NOTE "6"
(TYP.)

RUN PIPE SIZE	BRANCH PIPE SIZE																				
	NPS	4"	6"	8"	10"	12"	14"	16"	18"	20"	22"	24"	26"	28"	30"	32"	34"	36"	42"	48"	
NPS	DN	100	150	200	250	300	350	400	450	500	550	600	650	700	750	800	850	900	1050	1200	
4"	100																				
6"	150	6																			
8"	200		6																		
10"	250			6																	
12"	300		12																		
14"	350			12																	
16"	400				12																
18"	450					12															
20"	500						12														
22"	550							12													
24"	600								12												
26"	650									12											
28"	700										12										
30"	750											20									
32"	800												20								
34"	850													20							
36"	900														20						
42"	1050															20					
48"	1200																25				
BAR No.			1				2					3				4				5	

DIMENSION TABLE
PLATE THICKNESS (D) OF BARS

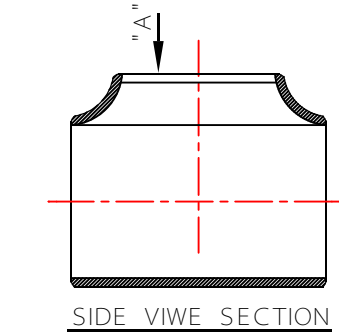

SIDE VIEW SECTION

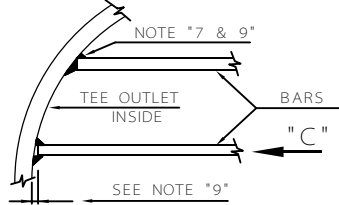

VIEW "A"

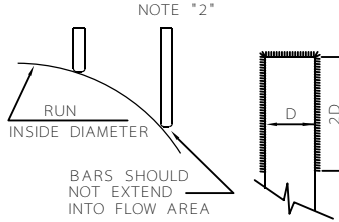

DETAIL "B"
NOTES "2" & "8"

VIEW "C"
NOTE "5"

NOTES

- 1 - ALL THICKNESS VALUES AND DIMENSIONS ARE IN mm.
- 2 - ALIGNMENT BARS TO BE SQUARE END CUT AND CORNER GROUND TO CONTOUR OF CROTCH & FLUSH MOUNTED IN LINE WITH THE INSIDE WALL OF RUN PIPE.
- 3 - FILLET WELDS OF BARS MUST NOT EXTEND INTO CROTCH OF TEE.
- 4 - BAR MATERIAL IS HOT ROLLED MILD STEEL PLATE UNLESS OTHERWISE SPECIFIED.
- 5 - PER STANDARD PRACTICE WELDING IS PERMITTED ON PLATE TYPE BARS IN ORDER TO MAINTAIN THE SPECIFIED CLEARANCE OF TEE.
- 6 - THIS DIMENSION SHALL BE SAME AS BAR PLATE THICKNESS USED IN OUTLET. IT MAY VARY DUE TO OUTLET HEIGHT AVAILABLE.
- 7 - SQUARE END CUT AND GROUND TO FIT OUTLET CONTOUR ALONG ONE CORNER OF BAR.
- 8 - SQUARE END CUT AND ROUND ALL SHARP CORNERS TO 3mm. RADIUS.
- 9 - CLEARANCE 1.5± 1.5 FOR ALL PLATES.
- 10 - FOR REINFORCEMENT & PROTECTION OF SCRAPER GUIDE BAR, EQUALLY SPACED GUIDE BAR SUPPORTS SHOULD BE USE AS FOLLOWING:

BRANCH DIAMETER	NO. OF GUIDE BAR SUPPORT	Ø DIA. mm
22"~30"	3	12
32"~48"	4	20

REV	DESCRIPTION	DATE
2		
1		
0		

IRANIAN PETROLEUM STANDARDS 
NO REVISION PERMITTED UNLESS APPROVED BY STANDARD ORGANIZATION

SCRAPER GUIDE BARS FOR PIPELINE TEES

DATE	DRAWING No.	SHEET	REV.
	IPS - D - PI - 149	1	0