

No.1 PERPENDICULAR BRACE

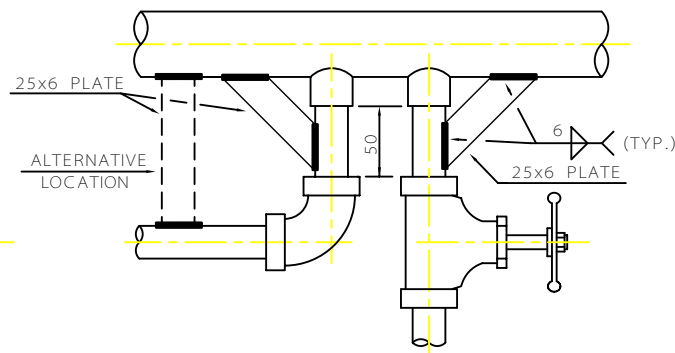

No.2 LONGITUDINAL BRACE

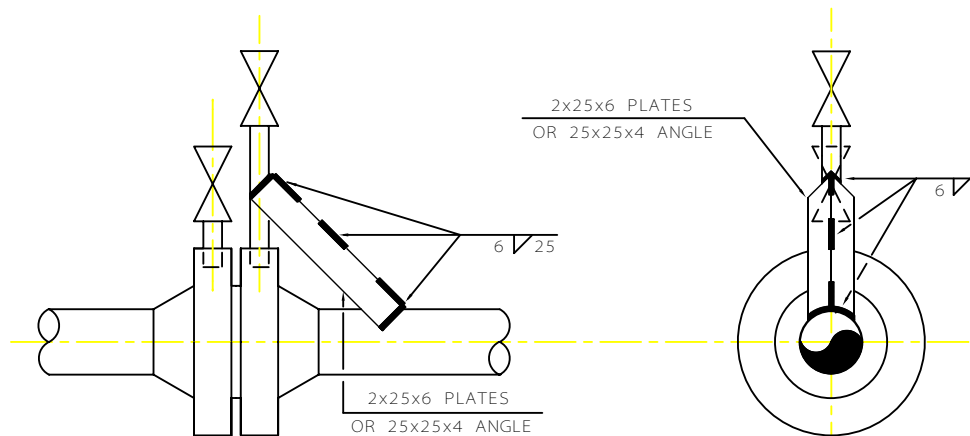

No.3 LONGITUDINAL BRACE

NOTES

- 1 - ALL THICKNESS VALUES & DIMENSIONS ARE IN mm.
- 2 - BRACE MATERIAL SHOULD BE THE SAME AS PIPE MATERIAL AND TO BE NOTED ON SPOOLS.
- 3 - WELDING PROCESS AND PROCEDURE SHALL CONFORM TO JOB SPEC.

THIS DWG. SUPERSEDES DWG. No. B - 0 - 5016

3		
2		
1		
REV	DESCRIPTION	DATE

IRANIAN PETROLEUM STANDARDS 
 NO REVISION PERMITTED UNLESS APPROVED BY STANDARD ORGANIZATION

VIBRATION BRACE

DATE	DRAWING No.	SHEET	REV.
	IPS - D - PI - 138	1	1