

90° BEND
WITH 3 SEGMENT

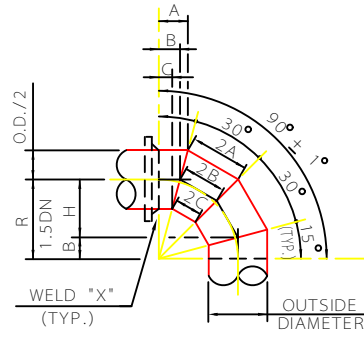

90° BEND
WITH 4 SEGMENT

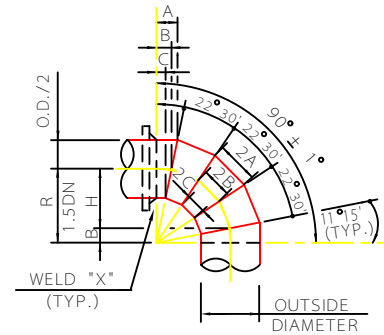

90° BEND
WITH 5 SEGMENT

SIZE		O.D. mm	R	90° BEND WITH 3 SEGMENT				90° BEND WITH 4 SEGMENT				90° BEND WITH 5 SEGMENT			
NPS	DN			A	B	C	H	A	B	C	H	A	B	C	H
4"	100	114.3	152.4	86.8	63.1	39.5	89.3	54.4	40.8	27.2	111.6	41.7	30.3	18.9	122.1
6"	150	168.3	228.6	129.5	94.7	59.8	133.9	81.7	61.2	40.8	167.3	62.2	45.5	28.7	183.1
8"	200	219.1	304.8	171.6	126.3	80.9	178.5	108.9	81.6	54.4	223.1	82.4	60.6	38.8	244.2
10"	250	273.0	381.0	214.4	157.8	101.3	223.2	136.1	102.0	68.0	278.9	102.9	75.8	48.6	305.2
12"	300	323.9	457.2	256.5	189.4	122.3	267.8	163.3	122.4	81.6	343.7	123.1	90.9	58.7	427.3
14"	350	355.6	533.4	294.6	220.9	147.2	312.5	190.6	143.0	95.3	390.4	141.5	106.1	70.7	488.3
16"	400	406.4	609.6	336.7	252.5	168.3	357.1	217.8	163.4	108.9	446.2	161.7	121.3	80.8	549.4
18"	450	457.2	685.8	378.8	284.1	189.4	401.7	245.1	183.8	122.5	502.0	181.9	136.4	90.9	610.4
20"	500	508.0	762.0	420.8	315.6	210.4	446.4	272.3	204.2	136.1	557.8	202.1	151.6	101.0	671.5
22"	550	558.8	838.2	462.9	347.2	231.5	491.0	299.5	224.6	149.8	613.6	222.3	166.7	111.2	732.5
24"	600	609.6	914.4	505.0	378.8	252.0	535.6	326.7	244.9	163.4	669.3	242.5	181.9	121.3	793.6
26"	650	660.4	990.6	547.0	410.3	273.5	580.3	354.0	265.3	177.0	725.1	262.7	197.0	131.4	854.6
28"	700	711.2	1066.8	589.2	441.9	294.6	624.9	381.2	285.7	190.6	780.9	282.9	212.2	141.5	915.6
30"	750	762.0	1143.0	631.3	473.4	315.6	669.6	408.4	306.3	204.2	836.7	303.1	227.4	151.6	976.7
32"	800	812.8	1219.2	673.3	505.0	336.7	714.2	435.7	326.7	217.8	892.5	323.3	242.5	161.8	1037.7
34"	850	863.6	1295.4	715.4	536.6	357.7	758.8	462.9	347.2	231.4	948.2	343.6	257.7	171.8	1098.8
36"	900	914.4	1371.6	757.5	568.1	378.8	803.5	490.1	367.6	245.1	1004.0	363.8	272.8	181.9	1159.8
38"	950	965.2	1447.8	799.6	599.7	399.8	848.1	517.3	387.9	258.7	1059.8	384.0	288.0	192.0	1220.9
40"	1000	1016.0	1524.0	841.7	631.3	420.8	892.7	544.6	408.4	272.3	1115.6	404.2	303.1	202.1	1281.9
42"	1050	1066.8	1600.2	883.8	662.8	441.9	937.4	571.8	428.7	285.9	1171.3	424.4	318.3	212.1	1342.9
44"	1100	1117.6	1676.4	925.8	694.4	462.9	982.0	599.0	449.2	299.5	1227.1	444.6	333.5	222.3	1404.0
46"	1150	1168.4	1752.6	968.0	725.9	484.0	1026.6	626.1	469.7	313.1	1282.9	464.8	348.6	232.4	1465.0
48"	1200	1219.2	1828.8	1010.0	757.5	505.0	1071.3	653.7	490.1	326.7	1338.7	485.0	363.8	242.5	1526.1
50"	1250	1270.0	1905.0	1052.1	789.0	526.0	1115.9	680.7	510.5	340.4	1394.5	505.3	378.9	252.6	1587.1
52"	1300	1320.8	1981.2	1094.2	820.6	547.1	1160.5	707.9	531.0	354.0	1450.2	525.4	394.1	262.7	1648.2
54"	1350	1371.6	2057.4	1136.3	852.2	568.1	1205.5	735.0	551.4	367.6	1506.0	545.7	409.2	272.8	1709.2
56"	1400	1422.4	2133.6	1178.4	883.8	589.2	1250.0	762.2	571.6	381.2	1561.8	565.9	424.4	282.9	1716.3
58"	1450	1473.2	2209.8	1220.5	915.3	610.2	1294.4	789.6	592.2	394.8	1617.6	586.1	493.5	293.0	1831.3
60"	1500	1524.0	2286.0	1262.6	946.9	631.3	1339.0	816.7	612.6	408.4	1673.3	606.2	454.7	303.1	2197.6
72"	1800	1828.8	2743.2	1515.1	1136.2	757.5	1606.8	980.0	735.0	490.1	2008.0	727.5	545.6	363.7	363.7

NOTES

- 1 - ALL THICKNESS VALUES & DIMENSIONS ARE IN mm.
- 2 - USAGE OF MITER BENDS AND No. OF PIECES DEPEND ON FLOW CONDITION AND TO BE CONFIRMED BY PROCESS DEPARTMENT.
- 3 - THE USAGE OF MITER BENDS IN HOT OR CRITICAL LINES SHALL BE CONFIRMED BY STRESS ANALYSIS GROUP.
- 4 - MITER BENDS MAY BUILT BY PIPE OR PLATE.
- 5 - FOR WELDING PROCEDURES AND DIMENSION REFER TO PROJECT WELDING SPECIFICATION.
- 6 - WELD "X" SHALL BE OMITTED EXCEPT WHEN FITTING OR FLANGE ARE USED TO THE MITERED ELBOW OR IF THE JOINT MUST BE FIELD WELD.

THIS DWG. SUPERSEDES DWG. No. A-0-5021 & S-2-L-652

3		
2		
1		
REV	DESCRIPTION	DATE

IRANIAN PETROLEUM STANDARDS 
NO REVISION PERMITTED UNLESS APPROVED BY STANDARD ORGANIZATION

MITER BENDS

DATE	DRAWING No.	SHEET	REV.
	IPS - D - PI - 129	1	2

SIZE		O.D. mm	R	45° BEND WITH 2 SEGMENT			45° BEND WITH 3 SEGMENT			
NPS	DN			A	B	C	A	B	C	M
4"	100	114.3	152.4	86.8	63.1	39.5	41.7	30.3	18.9	63.1
6"	150	168.3	228.6	129.5	94.7	59.8	62.2	45.5	28.7	94.7
8"	200	219.1	304.8	171.6	126.3	80.9	82.4	60.6	38.8	126.3
10"	250	273.0	381.0	214.4	157.8	101.3	102.9	75.8	48.6	157.8
12"	300	323.9	457.2	256.5	189.4	122.3	123.1	90.9	58.7	189.4
14"	350	355.6	533.4	294.6	220.9	147.2	141.5	106.1	70.7	220.9
16"	400	406.4	609.6	336.7	252.5	168.3	161.7	121.3	80.8	252.5
18"	450	457.2	685.8	378.8	284.1	189.4	181.9	136.4	90.9	284.1
20"	500	508.0	762.0	420.8	315.6	210.4	202.1	151.6	101.0	315.6
22"	550	558.8	838.2	462.9	347.2	231.5	222.3	166.7	111.2	347.5
24"	600	609.6	914.4	505.0	378.8	252.0	242.5	181.9	121.3	378.8
26"	650	660.4	990.6	547.0	410.3	273.5	262.7	197.0	131.4	410.3
28"	700	711.2	1066.8	589.2	441.9	294.6	282.9	212.2	141.5	441.9
30"	750	762.0	1143.0	631.3	473.4	315.6	303.1	227.4	151.6	473.4
32"	800	812.8	1219.2	673.3	505.0	336.7	323.3	242.5	161.8	505.0
34"	850	863.6	1295.4	715.4	536.6	357.7	343.6	257.7	171.8	536.6
36"	900	914.4	1371.6	757.5	568.1	378.8	363.8	272.8	181.9	568.3
38"	950	965.2	1447.8	799.6	599.7	399.8	384.0	288.0	192.0	599.7
40"	1000	1016.0	1524.0	841.7	631.3	420.8	404.2	303.1	202.1	631.3
42"	1050	1066.8	1600.2	883.8	662.8	441.9	424.4	318.3	212.1	662.8
44"	1100	1117.6	1676.4	925.8	694.4	462.9	444.6	333.5	222.3	694.4
46"	1150	1168.4	1752.6	968.0	725.9	484.0	464.8	348.6	232.4	725.9
48"	1200	1219.2	1828.8	1010.0	757.5	505.0	485.0	363.8	242.5	757.5
50"	1250	1270.0	1905.0	1052.1	789.0	526.0	505.3	378.9	252.6	789.0
52"	1300	1320.8	1981.2	1094.2	820.6	547.1	525.4	394.1	262.7	820.6
54"	1350	1371.6	2057.4	1136.3	852.2	568.1	545.7	409.2	272.8	852.2
56"	1400	1422.4	2133.6	1178.4	883.8	589.2	565.9	424.4	282.9	883.7
58"	1450	1473.2	2209.8	1220.5	915.3	610.2	586.1	439.5	293.0	915.3
60"	1500	1524.0	2286.0	1262.6	946.9	631.3	606.2	454.7	303.1	946.9
72"	1800	1828.8	2743.2	1515.1	1136.2	757.5	727.5	545.6	363.7	1136.2

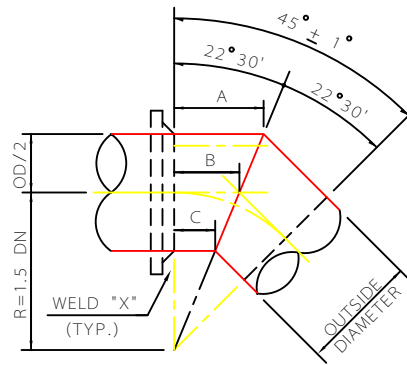

45° BEND
WITH 2 SEGMENT

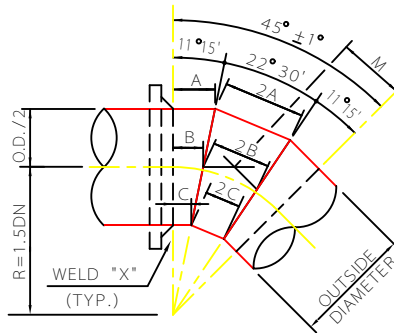

45° BEND
WITH 3 SEGMENT

NOTES

- 1 - ALL THICKNESS VALUES & DIMENSIONS ARE IN mm.
- 2 - USAGE OF MITER BENDS AND No. OF PIECES DEPEND ON FLOW CONDITION AND TO BE CONFIRMED BY PROCESS DEPARTMENT.
- 3 - THE USAGE OF MITER BENDS IN HOT OR CRITICAL LINES SHALL BE CONFIRMED BY STRESS ANALYSIS GROUP.
- 4 - MITER BENDS MAY BUILT BY PIPE OR PLATE.
- 5 - FOR WELDING PROCEDURES AND DIMENSION REFER TO PROJECT WELDING SPECIFICATION.
- 6 - WELD "X" SHALL BE OMITTED EXCEPT WHEN FITTING OR FLANGE ARE USED TO THE MITERED ELBOW OR IF THE JOINT MUST BE FIELD WELD.

THIS DWG. SUPERSEDES DWG. No. A-0-5021 & S-2-L-652

3		
2		
1		
REV	DESCRIPTION	DATE

IRANIAN PETROLEUM STANDARDS 
NO REVISION PERMITTED UNLESS APPROVED BY STANDARD ORGANIZATION

MITER BENDS

DATE	DRAWING No.	SHEET	REV.
	IPS - D - PI - 129	2	2