

TYPE 1

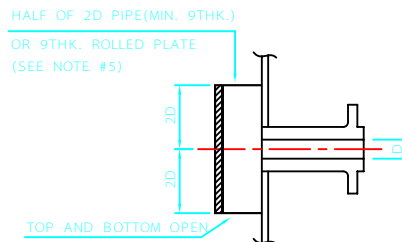

TYPE 2

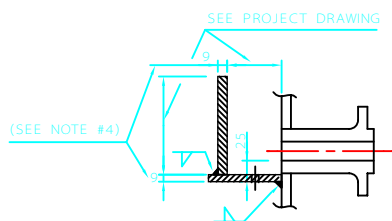
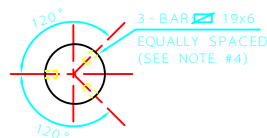
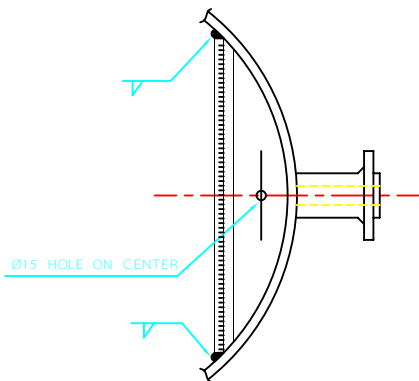

TYPE 3

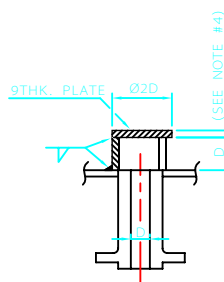

TYPE 4

GENERAL NOTES:

- 1- ALL DIMENSIONS ARE IN MILLIMETERS, UNLESS OTHERWISE INDICATED.
- 2- MATERIALS OF BAFFLE PLATES AND PIPES SHALL BE AS SPECIFIED ON THE VESSEL DRAWING.
- 3- CONSTRUCTION DETAIL DIMENSIONS AND MATERIALS IN DRAWINGS OR DATA SHEET SHALL TAKE PRECEDENCE OVER THOSE SHOWN HEREON.
- 4- WHERE CORROSION ALLOWANCE EXCEEDS 3.0 mm. , PLATE THK. AND PIPES. THK. SHALL BE INCREASED.
- 5- PLATE THICKNESS TO BE 6 FOR STAINLESS, ALLOY STEEL VESSELS, LINING OR CLADDED VESSELS.
- 6- WELDS SHALL BE CARRIED OUT AND INSPECTED AT SHOP AS PER VESSEL DESIGN CODE.
- 7- ALL WELD SHALL BE SAME AS BAFFLE THK. .

C		
B		
A		
REV	DESCRIPTION	DATE

IRANIAN PETROLEUM STANDARDS   
NO REVISION PERMITTED UNLESS APPROVED BY STANDARD ORGANIZATION

BAFFLE FOR COLUMN AND DRUM

DATE	DRAWING No.	SHEET	REV.
	IPS - D - ME - 031	1	1