



شرکت ملی گاز ایران

امور تدوین استانداردها

IGS

مشخصات فنی خرید

چراغهاي ال اي دي

LED Lighting Fixtures

## **FOREWORD**

This standard is intended to be mainly used by NIGC and contractors and has been prepared on interpretation recognized standards, technical documents, knowledge, backgrounds and experiences in gas industries at national and international levels. Iranian gas standards (IGS) are prepared, reviewed and amended by technical standard committees within NIGC Standardization division and submitted to the NIGC's "STANDARDS COUNCIL" for approval.

IGS Standards are subject to revision, amendment or withdrawal, if required, thus the latest edition of IGS shall be checked/inquired by NIGC users.

This standard must not be modified or altered by the end users within NIGC and her contractors. Any deviation from normative references and / or well known manufacturers specifications must be reported to Standardization division.

Any comments from concerned parties on NIGC distributed IGS are welcome to technical standards committees and will receive serious attention and consideration should a revision to standards is recommended .

## **GENERAL DEFINITIONS:**

Throughout this standard the following definitions, where applicable, should be followed:

1- "STANDARDIZATION DIV." has been organized to deal with all aspects of industrial standards in NIGC. Therefore, all queries for clarification or amendments are requested to be directed to mentioned div.

2- "COMPANY": refers to national Iranian gas company.

3- "SUPPLIER": refers to a firm who will supply the service, equipment or material to IGS specification whether as the prime producer or manufacturer or a trading firm.

4- "SHALL ": is used where a provision is mandatory.

5- "SHOULD": is used where a provision is advised only.

6- "MAY": is used where a provision is completely discretionary.

-----  
Website: <http://igs.nigc.ir>

E-mail: [igs@nigc.ir](mailto:igs@nigc.ir)

## Table of Content

| <u>No</u> | <u>Subject</u>  | <u>Page</u> |
|-----------|---|-------------|
| 1         | Scope   | 2           |
| 2         | References  | 2           |
| 3         | Terms and definitions                                 | 3           |
| 4         | General requirements                                  | 5           |
| 5         | General characteristics For LED fixture               | 6           |
| 6         | Connectors and terminals                              | 7           |
| 7         | Provisions for protective earthing                    | 7           |
| 8         | Protection against accidental contact with live parts | 7           |
| 9         | Moisture resistance and insulation                    | 8           |
| 10        | Electric strength                                     | 8           |
| 11        | Fault conditions                                      | 8           |
| 12        | Tests   | 8           |
| 13        | Conformity testing during manufacture                 | 10          |
| 14        | Creepage distances and clearances                     | 10          |
| 15        | Resistance to heat, fire and tracking                 | 10          |
| 16        | Resistance to corrosion                               | 11          |
| 17        | Packing and packaging                                 | 11          |
| 18        | Marking   | 11          |
| 19        | Documentation   | 12          |
| 20        | Data Sheet  | 13          |
| 21        | Figures   | 16          |

## 1- Scope

This Standard specification covers the minimum requirements for LED lighting fixtures excluding their control gears for use in general lighting on DC supplies up to 250 V or AC supplies up to 1000 V at 50 Hz.

*Note : IGS-M-EL-024-2(0) is considered for LED control gears .*

## 2- References

Throughout this standard specification the following standards are referred to. The editions of these standards that are in effect at the time of issue of this standard specification (2012) shall, to the extent specified herein, form part of this standard specification. The applicability of changes in standards that occur after the date of this standard specification shall be mutually agreed upon by the purchaser and the supplier.

### 2.1 Normative References

IEC 62031:2008 , *LED Modules for general lighting –Safety specifications.*

IEC/PAS 62717:2011(pre-standard), *LED modules for general lighting – Performance requirements.*

IEC 62560:2011, *Self-ballasted LED-lamps for general lighting services by voltage > 50 V – Safety specifications*

IEC/PAS 62612:2009, *Self-ballasted LED-lamps for general lighting services – Performance requirements*

IEC/PAS 62722-2-1:2011, *Luminaire performance – Part 2-1: Particular requirements for LED luminaires.*

IEC/TS 62504:2011, *General lighting – LEDs and LED modules – Terms and definitions*

### 2.2 Informative References

IEC 61347-2-13:2006, *Lamp control gear – Particular requirements for d.c. or a.c. supplied electronic control gear for LED modules.*

IEC 62384:2011, *DC or AC supplied electronic control gear for LED modules – Performance Requirements.*

IEC 60598-1:1989, *Luminaires, Part 1: General requirements and tests*<sup>1)</sup> *Amendment 1*

IEC 60838-2-2:2006, *Miscellaneous lamp holders – Part 2-2: Particular requirements, Connectors for LED modules*

IEC 61347-1-2007: *Lamp control gear – Part 1: General and safety requirements*

IEC 62471-2:2006, *Photo biological safety of lamps and lamp systems-Part 2 : Guidance on manufacturing requirements relating to non-laser optical radiation safety.*

IEC/PAS 62722-1:2011, *Luminaire performance – Part 1: General requirements*

CIE 13.3:1995 (CD008-1995 included), *Method of measuring and specifying color rendering properties of light sources.*

CIE 121:1996, *The photometry and goniophotometry of luminaires*

CIE 177:2007, *Color rendering of white LED light sources*

IEC/TR 61341, *Method of measurement of centre beam intensity and beam angle(s) of reflector lamps.*

IEC 61558-1:1998, *Safety of Power Transformers, Power Supply Units and Similar - Part 1: General Requirements and Tests*

IEC 60050-845:1998, *International Electrotechnical Vocabulary – Part 845: Lighting*

IEC/TR 61341:1994, *Method of Measurement of Centre Beam Intensity and Beam Angle(s) of Reflector Lamps First Edition*

IEC 61547:1995, *Equipment for General Lighting Purposes - EMC Immunity Requirements*

IEC 60061-1:2002, *Lamp caps and holders together with gauges for the control of interchangeability and safety*

IEC 60968:1999, *Self-ballasted lamps for general lighting services – Safety requirements.*

### **3- Terms and definitions**

#### **3.1 Light-emitting diode (LED)**

An LED is a solid state device embodying a p-n junction emitting optical radiation when excited by an electric current.

*Note1: LEDs are assembly of one or more LED Dies(p-n junctions) in a LED package, possibly with optical element and thermal, mechanical, and electrical interfaces. The device does not include the control unit of the control gear, does not include an IEC Standardized lamp cap, and is not connected directly to the mains.*

*Note2: LEDs in the today's market are mostly produced in three categories as 1) low power single die LED with power of below 0,5 watt(usually named "smd" LEDs), 2) High power single die LED with powers of 0.5, 1, 3 or 5 watt(or more in future) and 3) High power multi-die LEDs with powers of 10, 30, 50, 100 watts and more.*

*For more illustration see Figure F.1.*

#### **3.2 LED module**

Unit supplied as a light source. In addition to one or more LEDs, it may contain further components, e.g. optical, mechanical, electrical and electronic, but excluding the control gear.

*Note: The following types of LED modules are distinguished:*

- Type 1: Self-ballasted LED modules for use on dc supplies up to 250 V or on ac supplies up to 1 000 V at 50 Hz.*
- Type 2: LED modules operating with external control gear connected to the mains voltage, and having further control means inside ("semi-ballasted") for operation under constant voltage, constant, current or constant power;*
- Type 3: LED modules where the complete control gear is separate from the module for operation under constant voltage, constant current or constant power.*

*For more illustration see Figure F.2.*

### **3.3 LED lamp**

LED modules with integrated control gear and equipped with a lamp cap (thereby replacing existing lamps with identical lamp caps). In addition to one or more LEDs, it may contain further components, e.g. optical, mechanical, electrical and electronic, including the control gear.

*For more illustration see Figure F.3.*

### **3.4 LED luminaire**

Luminaire is incorporated with LED light sources (LEDs or LED modules).

*For more illustration see Figure F.4.*

### **3.5 LED lighting fixture**

In this standard we use the term “LED Lighting Fixture” or simply “LED Fixture” as a general term for any kind of LED light source such as LED lamp, LED module or LED luminaire (clauses 3.2 to 3.4 above).

### **3.6 Integral LED module**

LED module, generally designed to form a non-replaceable part of a luminaire.

### **3.7 Built-in LED module**

LED module, generally designed to form a replaceable part built into a luminaire.

### **3.8 Independent LED module**

LED module, so designed that it can be mounted or placed separately from a luminaire. The independent LED module provides all the necessary protection with regard to safety according to its classification and marking.

### **3.9 Electronic control gear**

Unit inserted between the supply and one or more LED modules which serves to supply the LED module(s) with its (their) rated voltage or rated current. The unit may consist of one or more separate components and may include means for dimming, correcting the power factor and suppressing radio interference. A control gear contains two main units, “power supply unit” which controls current, voltage or power within design limits and “control unit” which is responsible for controlling the electrical energy to the LEDs as well as color mixing, depreciating luminous flux and further performance features of LEDs.

*NOTE: In semi-ballasted LED modules, the control unit of the control gear is on board the module and separate from the power supply of the control gear.*

### **3.10 Rated value**

Nominal values for electrical parameters of a LED module for specific operating conditions which are specified in this standard, or assigned by the manufacturer or responsible vendor.

**3.11 Rated maximum temperature  $t_c$** 

Highest permissible temperature which may occur on the outer surface of the LED fixture under normal operating conditions and at the rated voltage/current/power or the maximum of the rated voltage/current/power range.

**3.12 Total circuit power**

Total power dissipated by LED lighting fixture, control gear in combination, at rated supply voltage and at the highest rated output load.

**3.13 Efficacy ( $lm/W$ )**

Quotient of the luminous flux emitted by the power consumed by the LED fixture.

**3.14 Circuit power factor  $\lambda$** 

Ratio of the measured circuit (the combination of control gear and the LED module(s)) power to the product of the supply voltage and the supply current.

**3.15 Color Rendering Index (CRI)**

CRI is used to measure how accurately a lighting source renders the color of objects when compared to sunlight. Sunlight is defined to have a CRI of 100, while white fluorescent lamps have CRI varying from the 50s to 98.

**3.16 Correlated Color Temperature (CCT)**

Indicates the color appearance of the light emitted by a source, relating its color to that of light from a reference source when heated to a particular temperature, measured in degrees Kelvin (K).

*Note: CCTs below 3500K represent a warm light similar to incandescent lamps, CCTs from 3500K to 4500K are neutral white and CCTs above 4500K usually considered cool like daylight.*

For further definitions, standards listed in clause 2 are referenced.

**4- General requirements**

**4.1** LED lighting fixtures shall be so designed and constructed that in normal use (see manufacturer's instruction) they operate without danger to the user or surroundings.

**4.2** Independent modules shall comply, in addition to IEC 62031 and IEC 62717, with the requirements of relevant clauses of IEC 60598-1.

**4.3** For self-ballasted LED modules, the electrical measurements shall be carried out at the tolerance limit values of the marked supply voltage.

*Note: in this standard LED lamps are considered as a kind of self-ballasted LED modules.*

- 4.4** Heat produced by LEDs during normal operation and in voltage/current/power limits shall be so dissipated that "Rated maximum temperature  $t_c$ " doesn't exceed.
- 4.5** LED lighting fixtures which are intended to be used in special areas such as hazardous classified, dusty, ingressive areas or other especial cases shall be certified for those areas/cases.
- 4.6** Photo biological Safety requirements shall comply with the requirements of IEC 62471.
- 4.7** Photometry and goniophotometry of luminaires shall be based on CIE 121:1996.
- 4.8** Measurement of centre beam intensity and beam angle(s) of reflector lamps and luminaires shall be done according to IEC/TR 61341.
- 4.9** Measuring and specifying color rendering properties of light sources shall be done based on CIE 13.3:1995 (CD008-1995 included) and CIE 177:2007.
- 4.10** Interface between lighting sources and control gears shall be based on IEC 62836-207
- 4.11** For compliance with EMC requirements, reference is made to IEC 61547 and regional requirements.

## **5. General characteristics For LED fixtures:**

General specifications of LED fixtures shall be based on clauses 9 to 12 and 15 to 19 of IEC 62031 and annexes A and B of IEC 62717. These characteristics include following topics which partly are further explained in clauses 12 to 21 of this standard:

- Provisions for protective earthing
- Protection against accidental contact with live parts
- Moisture resistance and insulation
- Electric strength
- Correlated color temperature (CCT)
- Color rendering index (CRI)
- Information for luminaire **design**
- Safety requirements under fault conditions
- Construction
- Creepage distances and clearances
- Resistance to heat, fire and tracking
- Resistance to corrosion
- Explanation of the photometric code



## 6- Connectors and Terminals

The requirements of IEC 60838-2-2 shall be used together with the followings:

- 6.1 The rated operating temperature range is  $-30^{\circ}\text{C}$  to  $+65^{\circ}\text{C}$ . The lower value has to be complied with by all systems unless they are restricted to indoor use only.
- 6.2 Minimum cross-sectional area for the connecting leads is  $0,22\text{ mm}^2$ . If flat cables are used, they shall have a minimum cross-sectional area of  $0,09\text{ mm}^2$ . Attention has to be paid to the maximum allowed current load for this cross-sectional area taking into account the rated current range is given in 7.2.
- 6.3 Connectors for LED modules shall be capable of maintaining good electrical contact to the module during rapid change of temperature and high humidity environment.
- 6.4 For resistance to excessive residual stresses (season cracking) and to rusting the requirements of Clause 17 of IEC 60838-1 shall be applied.
- 6.5 Connectors for LED modules shall be capable to satisfactorily maintain electrical contact to the module when affected to vibration in normal use.
- 6.6 For screw terminals, the requirements of IEC 60598-1, Section 14, shall be used, if applicable.
- 6.7 For screwless terminals, the requirements of IEC 60598-1, Section 15, shall be used, if applicable.

*NOTE: The electrical connection/clamping means shall be adequately locked against loosening, and it shall not be possible to loosen the electrical connection/clamping means by hand without the use of a tool. For screwless terminals, it shall not be possible to loosen the clamping means/electrical connection unintentionally. The requirements of IEC 61347-1, Clause 9, shall be applied.*

## 7- Provisions for protective earthing

- 7.1 The requirements of IEC 61347-1, Clause 9, shall be applied.
- 7.2 Earthing terminals shall comply with the requirements of clause 8 of IEC 62031.

## 8- Protection against accidental contact with live parts

LED lighting components shall be sufficiently protected against accidental contact with live parts when installed as in normal use.

Parts providing protection against accidental contact shall have adequate mechanical strength and shall not work loose in normal use. It shall not be possible to remove them without the use of a tool. The requirements of IEC 61347-1, Clause 10, shall be applied.

## 9- Moisture resistance and insulation

LED fixtures shall be moisture-resistant. They shall not show any appreciable damage after being subjected to the insulation resistance test described in IEC 61347-1, Clause 11. Wood, cotton, silk, paper and similar fibrous materials shall not be used as insulation.

## 10- Electric strength

LED fixtures shall have adequate electric strength. Immediately after the measurement of the insulation resistance, the Modules shall withstand an electric strength test for 1 min applied between the following parts:

- a) between live parts of different polarity which are or can be separated;
- b) between live parts and external parts, including fixing screws;
- c) between live parts and control terminals, where relevant.

## 11- Fault conditions

The LED fixtures shall not impair safety when operated under fault conditions that may occur during the intended use or, when operated under fault conditions, there shall be no emission of flames or molten material or production of flammable gases. The requirements of IEC 61347-1, Clause 14, apply additionally. "Overpower condition" test shall be performed (based on IEC 62030, Clause 13.2) to verify fault conditions.

## 12- Tests

### 12.1 General test conditions and requirements

**12.1.1** Tests according to this standard shall be type tests. The minimum sampling size for type testing shall be as given in Table 7 of IEC 62717. The sample shall be representative of a manufacturer's production.

*NOTE : Compliance of the type-test sample does not ensure compliance of the whole production of a manufacturer with this standard. Conformity of production is the responsibility of the manufacturer and may need routine tests and quality assurance in addition to type tests.*

**12.1.2** Unless otherwise specified (as mentioned in 5.1.1 above), type test shall be carried

out on one sample consisting of one or more items submitted for the purpose of the type test. In general, all tests shall be carried out on each type of product or, where a range of similar products is involved, for each wattage in the range or on a representative selection from the range, as agreed with the manufacturer.

**12.1.3** If the light output has detectably changed, the fixture shall not be used for further tests.

NOTE: Usually, a value of 50 % reduction of output light during the test indicates irreversible changes in the module.

**12.1.4** Unless otherwise specified, the tests shall be carried out at an ambient temperature of 10 °C to 30 °.

**12.1.5** All electrical measurements, unless otherwise specified, shall be carried out at voltage limits (min/max), current limits (min/max) or power limits (min/max) and minimum frequency, in a draught-free room at the temperature limits of the allowed range specified by the manufacturer. Unless the manufacturer indicates the most critical combination, all combinations (min/max) of voltage/current/power and temperature shall be tested.

**12.1.6** Integral modules not having their own enclosure shall be treated as integral components of luminaires as defined in IEC 60598-1, Clause 0.5. They shall be tested assembled in the luminaire.

**12.1.7** If the fixture is a factory sealed unit, it shall not be opened for any tests. In the case

of doubt based on the inspection of the fixture and the examination of the circuit diagram, and in agreement with the manufacturer or responsible vendor, such specially prepared fixtures shall be submitted for testing so that a fault condition can be simulated.

**12.1.8** For luminaires, general test conditions are based on clause 6.1 of IEC 62722-2-1.

## **12.2 LED module tests**

The requirements of Clauses 13 and 14 of IEC 62031, Clauses 5 to 11 of IEC 62717 and Annex H, Clauses H.1, H.2, H.4, H.7, and Subclause H.11.2 of IEC 61347-1, shall be applied.

*Note: for Annex H of IEC 61347-1, In H.1.3, ignore the first paragraph and In all clauses, replace "lamp", "(lamp) control gear" or "ballast" by "LED module".*

Important topics of above clauses are as followings:

- Dimensions
- Test conditions: General test conditions, Creation of module families to reduce test effort
- Module power
- Light output: Luminous flux, Luminous intensity distribution, peak intensity and beam angle
- Efficacy
- Chromaticity co-ordinates, correlated color temperature (CCT) and color rendering
- LED module life: Lumen maintenance
- Endurance tests: Temperature cycling test, Supply switching test, Accelerated operation life test
- Verification
- Fault conditions: Overpower condition
- Conformity testing during manufacture

### 12.3 General test conditions and tests for LED lamps

General test conditions and tests for LED lamps shall be based on clauses 6 to 10 of IEC/PAS 62612 and 8 to 13 of IEC/PAS 62650.

The important topics of above clauses are as followings:

- Test conditions
- Lamp wattage
- Luminous flux
- Correlated colour temperature and colour rendering: CCT, CRI
- Lamp life: Lumen maintenance, Endurance test for built-in electronic ballast
- Insulation resistance
- Electric strength
- Mechanical strength
- Cap temperature rise
- Resistance to heat
- Resistance to flame and ignition
- Fault conditions

### 12.4 Testing of luminaires

The requirements of Clauses 8 to 11 of IEC 62722-2-1 shall be applied. The tests for LED luminaires are same as those of LED modules and mostly are referred to IEC 62717.

### 13- Conformity testing during manufacture

This test is carried out at 100% of production. It is combined with the measurement of input power at rated voltage/current. The luminous flux of no module should be significantly lower than that of the rest of the production.

For independent and built-in modules, IEC 60598-1, Annex Q, is applicable, but without polarity check.

*NOTE: Very low values of the luminous flux indicate internal losses that may be safety relevant, like current bridges.*

### 14- Creepage distances and clearances

The requirements of IEC 60598-1, Section 11, shall be applied.

### 15- Resistance to heat, fire and tracking

**15.1** Parts of insulating material either retaining live parts in position or providing protection against electric shock shall be sufficiently resistant to heat.

Compliance is checked by subjecting the parts to the ball pressure test according to section 13 of IEC 60598-1.

**15.2** External parts of insulating material providing protection against electric shock and parts of insulating material retaining live parts in position shall be sufficiently resistant to flame and ignition/fire.

Compliance is checked by the tests of 18.3 or 18.4, of IEC 62031 as appropriate.

## 16- Resistance to corrosion

Ferrous parts, the rusting of which might cause the fixture to become unsafe, shall be adequately protected against rusting.

Compliance is checked by the test of 4.18.1 of section 4 of IEC 60598-1.

Protection by varnish is deemed to be adequate for the outer surfaces.

## 17- Packing and Packaging

Each LED fixture shall be packed according to NIGC packing instructions .

## 18- Marking

### 18.1.1 Mandatory marking for built-in or independent modules

- a) Mark of origin (trade mark, manufacturer's name or name of the responsible vendor/supplier).
- b) Model number or type reference of the manufacturer.
- c) Either the
  - rated supply voltage(s), or voltage range, supply frequency or/and
  - rated supply current(s) or current range, supply frequency (the supply current may be given in the manufacturer's literature) or/and
  - rated input power, or power range.
- d) Nominal power.
- e) Indication of position and purpose of the connections where it is necessary for safety. In case of connecting wires, a clear indication shall be given in a wiring diagram.
- f) Value of  $t_c$ . If this relates to a certain place on the LED module, this place shall be indicated or specified in the manufacturer's literature.
- g) For eye protection, see requirements of IEC 62471.
- h) Built-in modules shall be marked in order to separate them from independent modules. The mark shall be located on the packaging or on the module itself.

18.1.2 Further markings for LED modules shall be made according to IEC 62717 clause 4.

### 18.1.3 Location of marking on modules

Items a), b), c) and f) of 9.1 shall be marked on the module.

Items d), e), g) and h) of 9.1 shall be marked legible on the module or on the module data sheet.

For integral modules, no marking is required, but the information given in 9.1 a) to g) shall be provided in the technical literature of the manufacturer.

## 18.2 Luminaires

Information on the parameters shown in Table 1 of IEC 62722-2-1 shall be provided by the manufacturer or responsible vendor on the product datasheets, leaflets or website.

*NOTE: This information is in addition to the mandatory marking required by IEC 60598-1.*

**18.3 Durability and legibility of marking**

Marking shall be durable and legible.

Compliance is checked by inspection and by trying to remove the marking by rubbing the area lightly by hand for 15 s with a piece of smooth cloth, dampened with water.

The marking shall be legible after the test.

**19- Documentation**

The approval test reports shall be issued by certifying body which is accepted by N.I.G.C.

**20- Data Sheet**

| General |   |   |  |
|---------|---|---|--|
| No      | Specification   | Client requirement  | Vendor specification                         |
| 1       | Project Title/No.   |   |  |
| 2       | Client/Owner  |   |  |
| 3       | Supplier/Manufacturer   |   |  |
| 4       | Order No./Date  |   |  |
| 5       | Application   | Indoor<br>Out door<br>Others: .....                               | Flood lights<br>Street lighting              |
| 6       | Mounting type   | Surface mounted<br>flush mounted<br>Wall mounted<br>Others: ..... | Column mounted<br>pendant<br>Bracket mounted |
| 7       | Hazard Classification   | Hazardous : Zone:<br>safe area                                    |  |
| 8       | Source Voltage (volts)  | DC: .....<br>AC:110<br>AC:230                                     |  |
| 9       | Efficiency  | .....%  | .....%                                       |
| 10      | Power factor  | > 0.90  |  |
| 11      | Field of view<br>-Beam angle (deg.)                             | As Required<br>.....  |  |
| 12      | Color   | Pure white<br>Warm white<br>Other:                                |  |
| 13      | Color temperature   | .....K  |  |
| 14      | Color rendering index<br>(CRI)                                  | > 70  |  |
| 15      | Maintenance   | No maintenance for at least first 5<br>years of operation         |  |
| 16      | Working Temp. range   | -10 to 55° C<br>-30 to 40° C<br>Others: ....                      |  |
| 17      | Working Humidity range  | 10%-90% RH<br>Others: ....  |  |
| 18      | Max. Surface Temp.  | <60° C  |  |
| 19      | Total lumens per<br>luminaire/Module/Lamp                       | Required Lumens:<br>.....<br>.....                                |  |
| 20      | Total ( fixture & control<br>gear)Power Consumption,<br>(watts) |   |  |

|                   |   |  |   |
|-------------------|---|--|---|
| 21                | Electromagnetic Compatibility(EMC)              | No Magnetic Interference   |   |
| 22                | Harmful emission                                | No harmful infrared<br>No UV                                       |   |
| 23                | Certification for hazardous areas               | ATEX,IECX ,....  |   |
| 24                | Ingress protection                              | IP.....  |   |
| 25                | Dimming   | Dimmable<br>Non-Dimming  |   |
| 26                | Voltage Total harmonic dist (V <sub>THD</sub> ) | < 5%   |   |
| 27                | Light pollution                                 | No wasted light  |   |
| 28                | Life time                                       | Over 50000 hours continuous operation                              |   |
| 29                | Dimensions, including dimensional tolerances    | .....  | .....                                       |
| 30                | Guarantee / Warranty                            | .....  |   |
| <b>Luminaire</b>  |   |  |   |
| 1                 | standards                                       | IEC/PAS 62722-2-1  |   |
| 2                 | Model number                                    |  |   |
| 3                 | Manufacturer                                    |  |   |
| 4                 | Country of origin                               |  |   |
| 5                 | Luminaire shape                                 | Linear<br>Rectangle<br>Artificial<br>Others: .....                 | Street lighting<br>Floodlight<br>Decorative |
| 6                 | Luminaire Type                                  | Integral<br>Built-in<br>Others: .....                              |   |
| 7                 | Body Material                                   | Metal sheet<br>Die-cast iron<br>Die-cast aluminum<br>Others: ..... |   |
| <b>LED Module</b> |   |  |   |
| 1                 | standards                                       | IEC 62031, IEC/PAS 62717,  |   |
| 2                 | Model number                                    |  |   |
| 3                 | Manufacturer                                    |  |   |
| 4                 | Country of origin                               |  |   |
| 5                 | Module shape                                    | Linear<br>Artificial<br>Others                                     | Rectangle<br>Decorative                     |



|                  |                                      |  |  |
|------------------|--------------------------------------|--|--|
| 6                | LED Module Type                      | Independent<br>Independent Semi Ballasted<br>Independent Self Ballasted<br>Others :..... |  |
| 7                | Body Material                        | Metal sheet<br>Die-cast aluminum<br>Others :.....  |  |
| <b>LED lamps</b> |                                      |  |  |
| 1                | standards                            | IEC 62612, IEC 62560   |  |
| 2                | Model number                         |  |  |
| 3                | Manufacturer                         |  |  |
| 4                | Country of origin                    |  |  |
| 5                | Base type                            | E types:<br>R types:   |  |
| 6                | Body Material                        | Metal sheet<br>Die-cast aluminum<br>Others :.....  |  |
| <b>LED Die</b>   |                                      |  |  |
| 1                | standards                            | Future/Manufacturer  |  |
| 3                | Model number                         |  |  |
| 4                | Manufacturer                         |  |  |
| 5                | Country of origin                    |  |  |
| 6                | Forward/Reverse Voltage              |  |  |
| 7                | Current                              |  |  |
| 8                | Wattage                              |  |  |
| 9                | Color                                |  |  |
| 10               | High shock/vibration characteristics | High shock/vibration resistant   |  |
| 11               | LED cathode temp.                    | < 60° C  |  |

**21- Figures**



**Fig 1 LED**

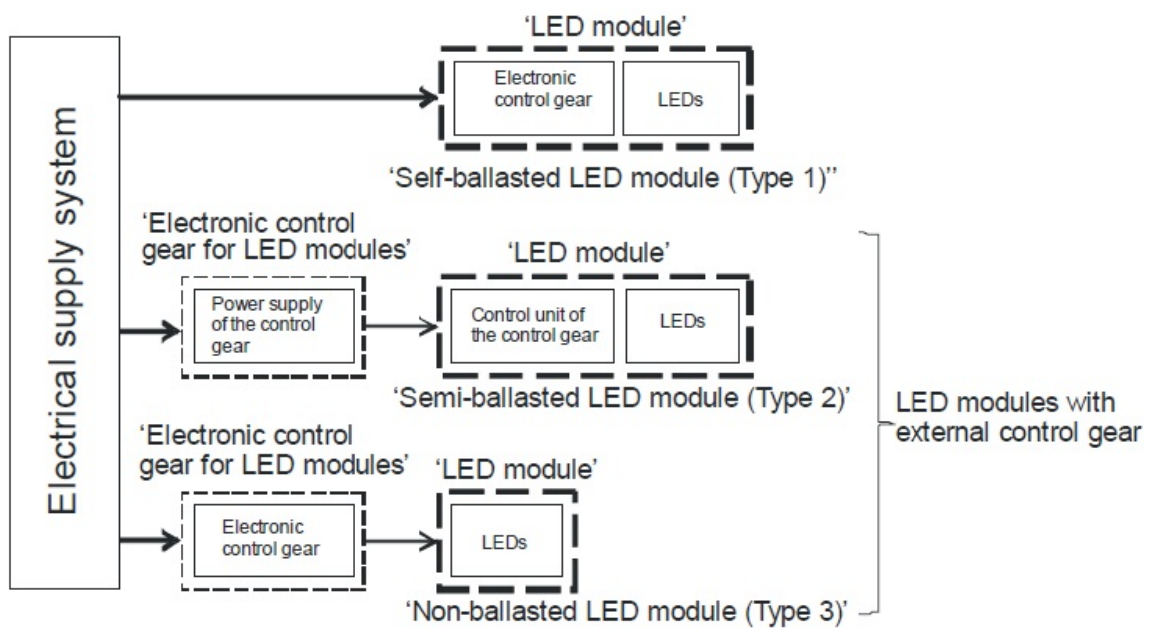

**Figure F.2a – Illustration for LED Module Types**

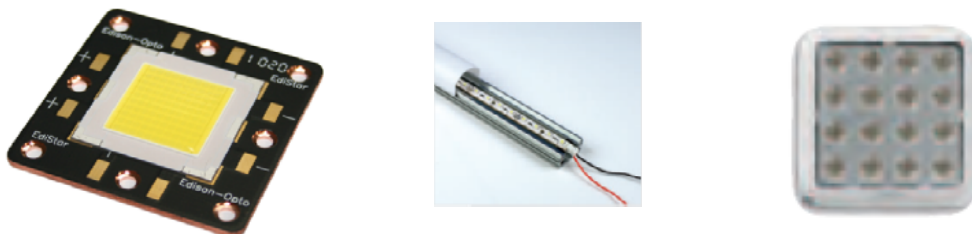

**Figure F.2b - LED Modules**

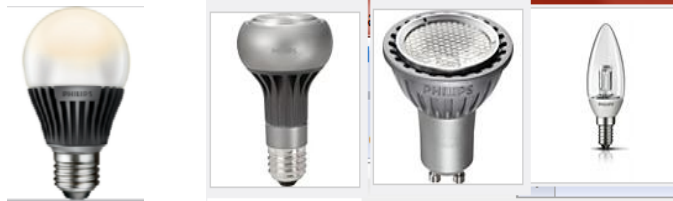

**Fig 3 - LED Lamps**



**Fig4 - Luminaires**